

Research of NiMH Battery Modeling and Simulation Based on Linear Regression Analysis Method

Chang-hao Piao^{*1,2}, Qing-yong Qin¹, Qian Zhang¹, Yong-sheng Zhang¹

¹Institution of Pattern Recognition and Applications, Chongqing University of Posts and Telecommunications, Chongqing 400065 China;

²State Key Laboratory of Vehicle NVH and Safety Technology, Chongqing 401120 China)

*Corresponding author, e-mail: 13638311195@163.com

Abstrak

Estimasi formula-pengisian baterai adalah salah satu isu utama pada pengembangan sistem manajemen baterai kendaraan listrik, dan model akurat yang lebih tinggi diperlukan pada estimasi formula-pengisian baterai. Oleh karena itu, pemodelan dan simulasi baterai yang akurat perlu diteliti. Model rangkaian Thevenin ekuivalen dari baterai NiMH membuktikan akurasi yang buruk untuk pemodelan tradisional. Berdasarkan data yang diturunkan dari eksperimen pengujian siklus pulsa hibrid baterai NiMH 6V 6Ah, parameter model Thevenin diidentifikasi dengan menggunakan metode analisis regresi linier. Selanjutnya, model simulasi rangkaian ekuivalen baterai dikembangkan pada lingkungan MATLAB/Simulink. Hasil simulasi dan eksperimen menunjukkan bahwa model yang dikembangkan memiliki akurasi yang lebih baik dan dapat digunakan untuk memandu estimasi formula-pengisian baterai.

Kata kunci: Baterai NiMH, rangkain ekuivalen, regresi linier, identifikasi parameter, pemodelan dan simulasi

Abstract

The battery state-of-charge estimation was one of core issues in the development of electric vehicles battery management system, and higher accurate model was needed in state-of-charge estimation correctly. Therefore, accurate battery modeling and simulation was researched here. The Thevenin equivalent circuit model of NiMH battery was established for the poor accuracy of traditional model. Based on the data which were brought from the 6V 6Ah NiMH battery hybrid pulse cycling test experiments, Thevenin model parameters were identified by means of the linear regression analysis method. Then, the battery equivalent circuit simulating model was built in the MATLAB/Simulink environment. The simulation and experimental results showed that the model has better accuracy and can be used to guide the battery state-of-charge estimation.

Keywords: NiMH battery, Equivalent circuit, Linear regression, parameter identification, modeling and simulation

1. Introduction

The environment pollution and the energy shortage are increasingly serious, thus reaches on the new energy vehicles cause worldwide attention. The power battery and battery management system are core component of the new energy vehicles, which has a significant impact on the vehicle's dynamics, the accuracy and the stability. Battery modeling reflects outer dynamic characteristics, which is the key point in battery State-Of-Charge estimation and plays an important role in the design of the battery management system [1].

The battery's internal chemical reaction is really a complex process. The temperature, State-Of-Charge, current and other factors also present a nonlinear effect on the battery. Thus, researchers have difficulty in applying a perfect model to accurately describe the performance of the battery. The battery model accuracy largely restricts the accuracy of the estimated battery State-Of-Charge, which thereby indirectly affects the performance of electric vehicles and their promotion. Commonly used battery models are electrochemical model, thermal model, neural network model, etc [2]. Electrochemical model and thermal model have high the Electrochemical knowledge of the researchers and also have to consider the parameters of the study objects battery indicators such as the battery type, size, shape. Therefore, they have significant limitations. The accuracy of the neural network model depends heavily on the training data and

training methods, and the neural network model trained by the data can only be used within the scope of the training data. Thus neural network model is only suitable for the mass production of mature battery.

Thevenin equivalent circuit model used in this paper [3] apply the ideal voltage source, the circuit components such as resistors and capacitors to simulate the battery dynamic characteristics, which has characteristics of simple, easy to understand and easy modeling simulation. The equivalent model unwanted researchers have solid electrochemical background knowledge and it is applicable to the different types of batteries. Researchers don't need to consider many factors such as the size and shape of the battery. The analysis of the simulation and testing results show that the applied model has better precision in the constant current and alternating current discharge conditions. It also meets follow-up engineering needs of the battery management system in State-Of-Charge estimation.

2. Battery characteristics and equivalent circuit model

2.1. NiMH battery characteristics

Similar to other types of batteries, the characteristics of NiMH battery is closely related to the State-Of-Charge, and the temperature is also one key factor in affecting the characteristics of the battery. Assuming that the test environment temperatures, the correspondence relationship between the voltage and the battery parameters can be processed linear at different State-Of-Charge points and its vicinity (here select the State-Of-Charge from 10% to 100%). All these characteristics provide theoretical basis and practical methods to establish the battery model and its parameters identification [4],[5].

This article applies a NiMH battery module as the research object. The battery discharging terminal voltage versus time curve, which measured by CI 3001W 20V30A high precision battery performance test system, shows that in Figure 1.

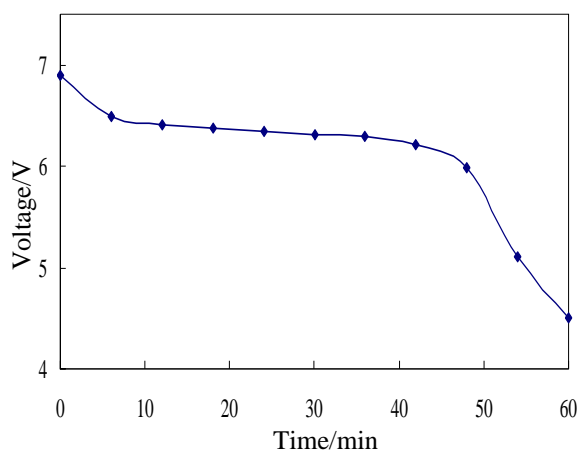

Figure 1. Battery discharge voltage versus time curve

As can be seen from the Figure1, the battery voltage drops sharply in discharging terms of the initial and final. The battery is a platform when the State-Of-Charge is more than 10% and less than 80%, during which the terminal voltage variation is relatively stable.

The dynamic operating characteristics of the batteries exhibit a combination of characteristics of the voltage source, resistor and capacitor. Therefore, the battery model applied the circuit components such as constant voltage source and resistor-capacitor network circuit network is such a simple structure, easy to write mathematical models and also exclude the complex chemical reaction inside the battery.

2.2. Equivalent circuit model

Equivalent circuit model have the ideal model, Rint model [6], RC model and Thevenin model, etc. Thevenin equivalent circuit model has advantages of mathematical model in low

order and high accuracy in battery features simulating. Under conditions of constant temperature, the parameters such as U_{oc} , R_0 , R_p and C_p in Thevenin model (see Figure 2) are all the function of the State-Of-Charge. According to Kirchhoff circuit laws, mathematical model of Thevenin model are as follows equations (1) and (2).

$$U_L = U_{oc} - IR_0 - I_p R_p \quad (1)$$

$$\dot{U}_p = -\frac{1}{C_p R_p} U_p + \frac{1}{C_p} I \quad (2)$$

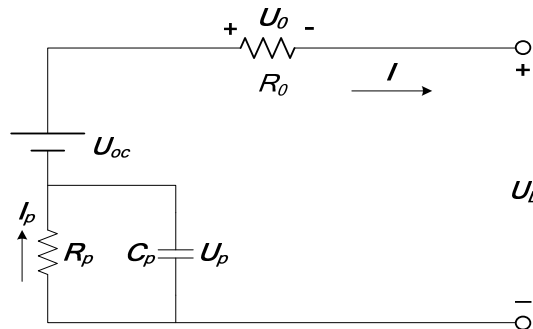

Figure 2. Thevenin equivalent circuit model

In Figure 2, I is the total current, I_p is the current through the polarization resistance, U_{oc} is the open-circuit voltage, U_L is the load voltage. R_p and C_p describe the capacitance characteristics of the battery. When there is current flow through the circuit, the battery terminal voltage changes mutation and gradient mutation, which are manifested in the polarization resistance R_p and gradient performance in polarization capacitance C_p .

3. Battery experiments and model parameters identification

The establishment of equivalent circuit, shown in Figure 2, is based on the battery cell, which presents a problem whether it is applicable to the battery module and battery pack. Test data had shown that voltage curves of battery module and pack have accurate multiplication relationship. Accordingly, the equivalent circuit modeling can be directly applied to battery modules and battery pack modeling. Here, the hybrid pulse cycling tests are carried out directly on a NiMH battery module, and the Thevenin model parameters are identified based on linear regression analysis.

3.1. Hybrid pulse cycling tests

All tests were performed at room temperature ($25\text{ }^\circ\text{C} \pm 5\text{ }^\circ\text{C}$) conditions. Although the discharge process of the battery is a complex non-linear process, the battery voltage curve can be regarded as a linear variation at each State-Of-Charge point and its vicinity.

In order to fully excavate the battery characteristics, the implementation of hybrid pulse cycling tests on the NiMH battery module [7], which detailed operating steps are the followings:

- Step 1: Charge the battery module for one hour at constant 6A, and then charge the battery to fully charged (SOC=100%) at constant 7.2V. A hybrid pulse test is carried out after one hour battery leaving aside. Record the data of battery terminal voltage U_L , current I , sample time (sample time is 1 second), etc.
- Step 2: Discharge the battery at 6A current for 6min to SOC=90%. Set aside the battery for one hour, and another hybrid pulse test executed on the battery module. Record the same data as the step 1.
- Step 3: Used the same method as in step 2, the uniform hybrid pulse test is cycling carried out on the battery module at the SOC are respectively 80%, 70%, 60%, 50%, 40%, 30%, 20%, 10%. Record the experimental data.

The profiles of the hybrid pulse test are as shown in Table 1 and Figure 3. As shown in Figure 4, the battery terminal voltage response curve of the hybrid pulse test. Each hybrid pulse test is a high-current battery charge and discharge, and the battery is shelved for a long time between the two adjacent tests. Thus, the complex chemical reactions inside the battery can fully be manifested on the performance of battery external characteristics. Throughout the testing processes, positive number indicates the discharge and negative indicates charging.

Table 1. Hybrid pulse test current profile

Time Increment (s)	Cumulative Time(s)	Current Value (A)
10	10	6
40	50	0
10	60	-6

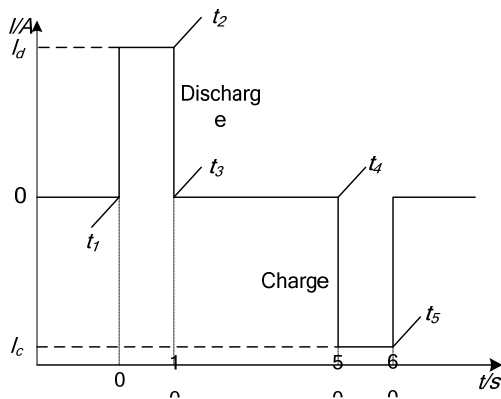

Figure 3. Hybrid pulse test current curve

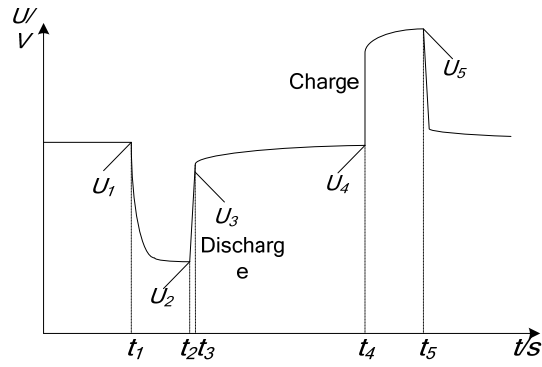

Figure 4. Hybrid pulse test voltage response curve

3.2. Model parameters identification

The same hybrid pulse cycling tests are implemented at different State-Of-Charge points, the identification of the model parameters is more reasonable. Hybrid pulse test data is got which are required for model identification for each point of the selected State-Of-Charge. A multiple linear regression equation is built according to Thevenin model, and the LINEST function in EXCEL is used to achieve model parameters identification by means of the least squares method [8].

According to the mathematical model of equation (1) of Thevenin equivalent circuit, its multiple linear regression model [9] can be expressed as

$$Y = \beta_1 + \beta_2 X_2 + \beta_3 X_3 + e \tag{3}$$

Where, Y is the dependent variable, X_i is the independent variable, β_j is regression coefficients, and e is a random error which is generally subject to normal distribution $N(0, \sigma^2)$, $i = 1, 2, 3, j = 1, 2, 3$.

Suppose there are n groups of observations $(Y_i, X_{i2}, X_{i3}) = (U_{Li}, I_i, I_{pi})$, $i = 1, 2, \dots, n$, then the equation (3) can be expressed as

$$Y_i = \beta_1 + \beta_2 X_{i2} + \beta_3 X_{i3} + e_i \tag{4}$$

Written in the matrix form

$$Y = X\beta + e \quad (5)$$

With sample linear regression equation(6) to fit the general linear regression equation.

$$\hat{Y} = \hat{\beta}_1 + \hat{\beta}_2 X_2 + \hat{\beta}_3 X_3 \quad (6)$$

Parameter estimation in multiple linear regression analysis applies the least squares method, and least squares method is to make the deviation squared sum of observations Y to fitting values \hat{Y} minimum. That is, the sum of squared residuals Q minimum.

$$Q = \sum (Y - \hat{Y})^2 \quad (7)$$

Regression coefficients can be obtained according to the multi-function extremum value principle.

$$\hat{\beta} = (XX^T)^{-1} XY^T \quad (8)$$

$$\text{Where, } X = \begin{bmatrix} 1 & X_{12} & X_{13} \\ 1 & X_{22} & X_{23} \\ \vdots & \vdots & \vdots \\ 1 & X_{n2} & X_{n3} \end{bmatrix}_{n=60} = \begin{bmatrix} 1 & I_1 & I_{p1} \\ 1 & I_2 & I_{p2} \\ \vdots & \vdots & \vdots \\ 1 & I_{60} & I_{p60} \end{bmatrix}, Y = \begin{bmatrix} Y_1 \\ Y_2 \\ \vdots \\ Y_n \end{bmatrix}_{n=60} = \begin{bmatrix} U_{L1} \\ U_{L2} \\ \vdots \\ U_{L60} \end{bmatrix}, \hat{\beta} = \begin{bmatrix} \hat{\beta}_1 \\ \hat{\beta}_2 \\ \hat{\beta}_3 \end{bmatrix},$$

$$\beta = \begin{bmatrix} \beta_1 \\ \beta_2 \\ \beta_3 \end{bmatrix} = \begin{bmatrix} U_{oc} \\ R_0 \\ R_p \end{bmatrix}, \hat{\beta} \text{ is an unbiased estimator of } \beta.$$

The polarization current I_p recursive calculation in regression analysis in EXCEL with reference to equation (9):

$$I_{p,j} = [1 - (1 - e^{-\Delta t/\tau})/(\Delta t/\tau)] \times I_{L,j} + [(1 - e^{-\Delta t/\tau})/(\Delta t/\tau) - e^{-\Delta t/\tau}] \times I_{L,j} + e^{-\Delta t/\tau} \times I_{p,j-1} \quad (9)$$

Where, $\Delta t = 1$ is sample time, $\tau = R_p C_p$ is time constant (usually within 10 seconds).

The regression analysis fit goodness of model parameters is determined by multiple determination coefficient R^2 . According to the statistical law

$$\sum (Y_i - \bar{Y})^2 = \sum (\hat{Y} - \bar{Y})^2 + \sum (Y - \hat{Y})^2 \quad (10)$$

Where, $\sum (Y_i - \bar{Y})^2$ is total sum of squares TSS of Y, and $\sum (\hat{Y} - \bar{Y})^2$ is regression sum of squares RSS, and $\sum (Y - \hat{Y})^2$ is the residual sum of squares ESS. Formula (10) can be rewritten as

$$TSS = RSS + ESS \quad (11)$$

Determining coefficient is defined as

$$R^2 = \frac{RSS}{TSS} = \frac{TSS - ESS}{TSS} = 1 - \frac{ESS}{TSS} \quad (12)$$

According to formula (7), adjust τ to make ESS minimum. Determining coefficient is closer to 1, the better the value is, and the higher the accuracy of estimation is.

4. Simulating model built and results analysis

4.1. Built the simulating model

In order to verify the model accuracy and performance of the model parameters identification, the battery equivalent circuit simulating model (as shown in Figure 5) is built in MATLAB/Simulink software [10]. The model input terminals 1 side and 2 is connected to a constant current or an alternating current load. Outputs side of the simulating model is the harness of terminal voltage signal and State-Of-Charge. The load current model is the input variable of the battery voltage and State-Of-Charge calculating modules, where the voltage is computed through the battery equivalent circuit equation and the State-Of-Charge derived by Ampere-hour integration method. The current sign of the input terminals 1 and 2 represents that the discharge or charging status.

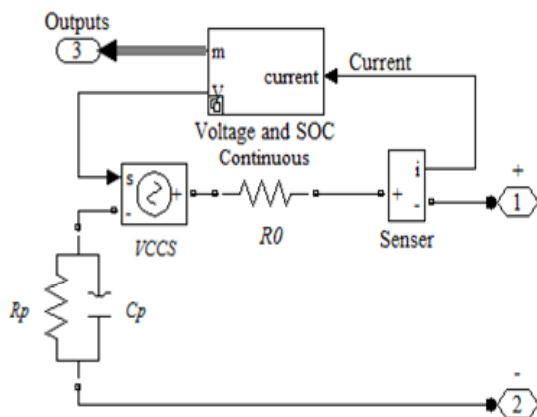

Figure 5. Battery simulating model

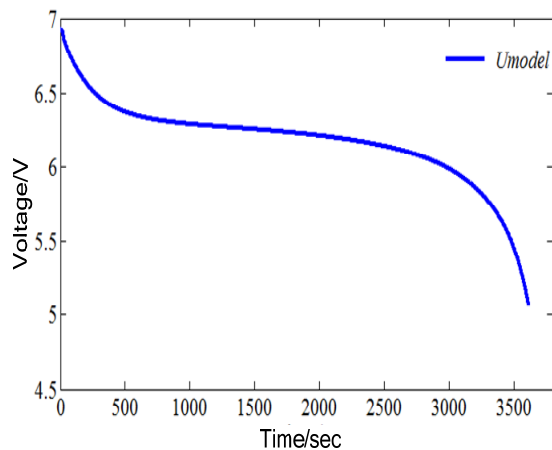

Figure 6. Simulation battery discharge at constant 6A results

Ampere-hour integration method needs to know battery initial State-Of-Charge. Therefore, the battery initial State-Of-Charge needs to be determined at the beginning of the simulation time. Figure 6 is a fully charged battery's simulation results at constant-current discharge of 6A.

4.2. Analysis of the results

The battery model of excellent performance can simulate the battery terminal voltage changes with a constant current load or alternating current load conditions. Verify battery model accuracy should be judged from the constant current and dynamic changing current. As shown in Figure 6, the accuracy of the battery model is measured by the output voltage error value corresponding to battery State-Of-Charge. In the case of a given load current, and other conditions, there is a correspondence relationship between the battery output voltage and battery State-Of-Charge. Therefore, the voltage difference or voltage difference percentage can be applied to judge the accuracy of the battery model. The voltage error ΔU is the difference between battery the test voltage U_{test} and model simulation values U_{model} .

$$\Delta U = |U_{test} - U_{model}| \tag{13}$$

Model simulation current and battery test current are 6A, and the initial State-Of-Charge is equal to 100%, and data sampling period is 1 sec. Figure 7 and Figure 8 respectively given the voltage curve of the battery model in the case of the constant current load, and the case of

alternating current load. Table 2 and Table 3 are voltage errors corresponding to these two situations.

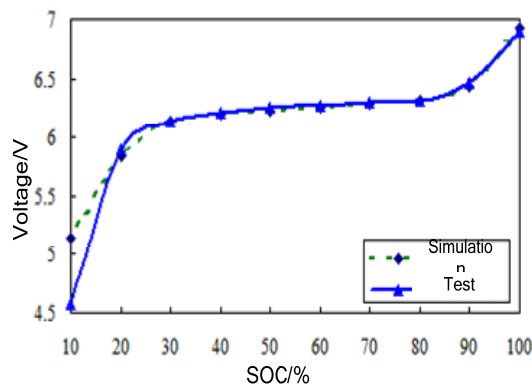

Figure 7. Constant current load voltage contrast curve

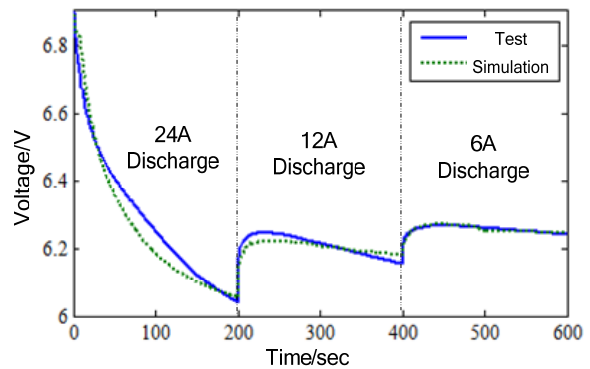

Figure 8. Alternating current load voltage contrast curve

Table 2. Constant current load voltage error

State-Of-Charge and error values					
SOC	10%	20%	30%	40%	50%
error(mV)	569	325	8	21	16
SOC	60%	70%	80%	90%	100%
error(mV)	24	19	0	65	25

Table 3. alternating current load voltage error

	Max	Min	Avg.
error(%)	3.3%	0	1.65%

As can be seen from Table 2 battery voltage error of the constant current load, the error is larger when the battery SOC are larger and smaller, especially the maximum error when the SOC is less than 20%, which fits the characteristics of the actual battery discharge process experiences. Table 3, describing variable traffic load error, shows that the maximum error was 3.3% when the battery discharges at large current 24A, and shows that the error is small when battery discharges at small current, and the smallest error is 0. Error analyzing indicates that battery models were able to accurately simulate battery external characteristic either constant current load or change the current load.

5. Conclusions

Battery test data and simulation results show that:

- Battery model has an ideal analog performance both in constant current load and in alternating current load. The voltage error is relative larger when State-Of-Charge is low in constant current load and large discharge current 24A phase in variable current load.
- The voltage error of the battery model is larger under the constant current load than alternating current load. Under a large current discharge in the varying current demand, the error is large compared to the error in the small current demand.
- Due not to consider the battery temperature and aging factors effect on the model parameters changing, which results that battery voltage error increasing over time in variable current demand 24A discharge. So the model parameters self- adaptive methods need to be further in-depth study.

Acknowledgement

This research was supported by Natural Science Foundation Project of CQ CSTC2010BB2400 and CSTC2010GGA063.

References

- [1] Qing-quan Chen, Feng-chun Sun, Jia-guang Zhu. Modern Electric Car Technology. Beijing: Beijing Institute of Technology Press. 2004.
- [2] Yu-jian Jia, Da Xie, Yu-jie Gu, Qian Ai, Zhi-jian Jin, Jie Gu. Classification and Characteristics of Equivalent Circuit Models for EV's Battery. *Power & Energy*. 2011; 32(6):516-521.
- [3] Cheng-tao Lin, Bin Qiu, Quan-shi Chen. Comparison of Current Input Equivalent Circuit Models of Electrical Vehicle Battery. *Chinese Journal of Mechanical Engineering*. 2005; 41(12):76-81
- [4] Hui-hui Hu, Cheng-lin Liao, Li-fang Wang. Modeling of MH/Ni Battery for Hybrid Electric Vehicles. *Battery Technology*. 2008.
- [5] Yi-feng Guo. Study on the Parameter Identification Method of Lead-acid Battery Equivalent Circuit Model. *Science Technology and Engineering*. 2012; 12(17):4165-4170.
- [6] Chang-hao Piao, Wen-li Fu, Gai-hui Lei, Chong-du Cho. Online Parameter Estimation of the Ni-MH Battery Based on Statistical Methods. *Energies*. 2009; 3(2):206-215.
- [7] Yun-fei Hu, Cheng-lin Liao, Li-fang Wang. Modeling of MH/Ni Battery for Hybrid Electric Vehicles. *Battery Technology*. 2008.
- [8] Zhi-hui Cai, Guo-fan Liu, Jing Luo. Parameter Identification of a Vehicle Battery Model based on EXCEL. *Journal of Hunan Institute of Engineering*. 2010; 20(4).
- [9] Wu-xiang Tang, Gui-zhi Cheng. Applications of Excel in Forecasting. Beijing:Publishing House of Electronics Industry. 2001:66-77.
- [10] Zhong-lin Huang. Kongzhi Xitong MATLAB Jisuan Fangzhen. 3rd Edition. Beijing:National Defence Industry Press. 2009.