

Effects of noises on near infrared sensor for blood glucose level measurement

Kiki Prawiroredjo, Engelin Shintadewi Julian

Electrical Engineering Department, Faculty of Industrial Technology, Trisakti University, Indonesia

Article Info

Article history:

Received Sep 9, 2019

Revised Jan 15, 2020

Accepted Feb 26, 2020

Keywords:

Light emitting diode

Near infrared light

NIR sensor

Photodiode

Sunlight

ABSTRACT

This paper proposed the method of measuring glucose level in solution using near infrared light (NIR) and photodiode sensor. We studied noises that occurred on the output signal of NIR sensor in three different room conditions in order to know the effects on this sensor output voltage stability. The sensor's circuit consisted of a 1450 nm NIR light emitting diode, a photodiode as the receiver, transimpedance amplifier, a notch filter, and a 4th order low pass filter. The results indicated that sunlight passing through windows was the most influencing factor caused the unstable sensor output voltage. Filters removed the effective voltages and the average sensor output voltages from the three rooms were 4.6825 V for air media, 2.2809 V for water media and 2.3368 V for glucose solution media. The output voltages tended to increase for one-hour measurement about 10 to 40 mV for air media, 40 to 90 mV for water media and 30 to 80 mV for glucose solution media. This sensor could only be used in a short time and suitable in a room without sunlight. Based on the voltage difference of the average sensor output voltage with water and glucose solution media, the sensor had the potential to be a blood glucose level meter.

This is an open access article under the [CC BY-SA](https://creativecommons.org/licenses/by-sa/4.0/) license.



Corresponding Author:

Kiki Prawiroredjo,

Electrical Engineering Department, Faculty of Industrial Technology,

Trisakti University,

1 Kiai Tapa St., Jakarta 11440, Indonesia.

Email: kiki.prawiroredjo@trisakti.ac.id

1. INTRODUCTION

Diabetes is a chronic, metabolic disease characterized by elevated levels of blood glucose or blood sugar. Diabetes of all types can lead to complications in many parts of the body and can increase the overall risk of premature death. The most common is type 2 diabetes, usually in adults, which occurs when the body becomes resistant to insulin or doesn't make enough insulin [1]. "Some 425 million people worldwide, or 8.8% of adults 20-79 years, are estimated to have diabetes. About 79% live in low and middle income countries" [2]. Persons suffering from diabetes may typically monitor their own glucose concentrations with periodic daily measurements, usually four times each day [3]. Unfortunately many patients do not monitor their blood glucose level at recommended frequency. It is partly due to the inconvenience, pain and tediousness of current monitoring techniques and due to the increased risk of infection when the blood skin barrier is broken, a non-invasive blood glucose monitor would be highly desirable. Many methods have been proposed for the non-invasive measurements but the main concern in non invasive technique is the difficulty in achieving high accuracy of results as no blood is directly involved in the process. Since 1980s, NIR spectroscopy has become a promising technique for in vivo analyses, with advantages such as rapidity,

non destructivity, and simplicity. Spectroscopic technique is an optical method used to detect blood glucose by determining the quantity of light which is either absorbed, transmitted or emitted as a function of glucose concentration [4]. Near-infrared radiation is a low energy electromagnetic wave, it is possible to avoid the occurrence of radiation damage of the sample [5]. A key finding related to the non-invasive measurement of glucose is that a major physiological response accompanies changes in glucose and can be detected non-invasively through the resulting changes in tissue properties [6]. A change of glucose concentration may modify the optical parameters in tissue, with the result that its glucose concentration can be extracted by analyzing the received optical signals [7]. A limitation of the near-infrared blood glucose measurement instruments is that each may be require to be custom calibrated for each individual user [8].

NIR sensor for blood glucose measurement has been investigated to develop non-invasive glucose monitoring systems and to get a high accuracy result of measurement. Shyqyri et al used 940 nm NIR LED as transmitter and passed the light beam through human fingertip and received the attenuated signal from the other side of the finger by a photodiode sensor. Their experimental study confirms a correlation between the sensor output voltage and glucose concentration levels [9]. Sia used 1450 and 2050 nm NIR LED and photodiodes as the sensor to measure the voltage of 50, 100, 150 and 200 mg/dL glucose concentration. As glucose concentration increases, output voltage from photodiode also increases. The relations observed was linier [10]. Reddy et al developed a smart insulin device for non-invasive blood glucose level monitoring using 1550 nm NIR light on human fingertip. A photodiode received the reflected infrared signal and converted to an equivalent voltage value. The concentration of glucose level is calculated based on the body mass index of the patient. Their results showed that there was a strong relationship between glucose concentration and sensor output voltage. Voltage increased as glucose concentration increased [11]. Unnikrishna et al proposed a method that is based on the principle of absorbance transmittance photometry. They used 950 nm NIR LED as the transmitter and a phototransistor as the receiver to monitor human blood glucose [12]. Pande and Joshi in 2015 in their article presented a circuit for noninvasive measurement of the glucose. They concluded that the transmitter with 1450-nm wavelength is more suitable [13].

A limitation in many photodiode applications is a back ground noise floor which masks the signal detected by the photodiode. A contributing factor to background noise in a photodiode detector circuit, as in most electronic circuits, is the parasitic coupling of electromagnetic interference (EMI) into the circuit [14]. Moreover, ambient and/or environment interference (i.e. noise) can adversely affect the measurement accuracy. Interference is generated by many commonly-used electrical devices. In a typical household for example, electric power lines and outlets, ambient lights, light dimmers, television or computer displays, and power supplies or transformers generate electromagnetic interference [15]. In photodiode itself there are sources of noise, these are flicker (1/f) noise, Johnson noise and shot noise [16]. As a preliminary research in developing a blood glucose level sensor, we studied whether NIR sensor is susceptible to noises. We measured the output voltage of the sensor with this proposed design in three different places with different conditions and with three different media between the NIR light emitting diode and photodiode and observed noises that occurred. The purpose of this studied was to know the effects of noises to sensor output voltage stability.

2. RESEARCH METHOD

The block diagram of the proposed system consists of input, process and output section as shown in Figure 1. The transmitter circuit in the input section is a 1450 nm NIR LED where the glucose absorption is high [17]. It emits NIR light through media and an infrared photodiode receives the light after passing through the media. The transmittance setup is recommended for non-invasive glucose monitoring [18]. The LED and InGaAs infrared photodiode used in this research are from ThorLabs.

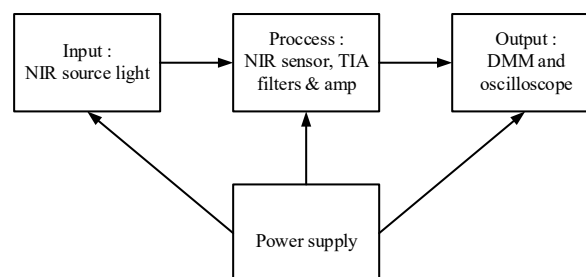

Figure 1. System block diagram

The principle of measuring glucose level with a NIR light source and a photodiode sensor is the domain of spectrometry. Spectrometry is an analyzing method that studies the interaction between material substances with electromagnetic wave radiation. This interaction changes the direction of light wave radiation and decreases the light intensity received by the photo detector. For spectrophotometric experiments, Beer Lambert's law is applicable to measure the attenuation of light that is proportional to the level of glucose solution, thickness of the sample and molar extinction coefficient. The (1) shows the attenuation A according to Beer Lamberts law [19].

$$A = \log\left(\frac{I_0}{I}\right) = ECl \quad (1)$$

where I_0 is transmitted light intensity, I is incident light intensity, E is extinction coefficient, C is level of glucose solution, and l is length of light path through solution being observed.

In the previous research we measured some glucose concentration in glucose solution with this proposed design and the results showed that higher glucose concentration yield lower sensor output voltage but it did not show a good linier trend [20]. This result is consistent with Beer Lambert's law. In this research we studied the sources of noise that made the non linier trend of output voltages from the sensor as the glucose concentration increase. The signal conditioning circuits are a transimpedance amplifier, a notch filter, a 4th order low pass filter and a final stage amplifier. The NIR sensor photodiode is fed to a transimpedance amplifier to convert the current from photodiode sensor to voltage as shown in Figure 2. The output voltage is filtered by a 50 Hz notch filter and a 5 Hz 4th order low pass filter to reduce low and high frequency noises. Figure 3 shows the 50 Hz notch filter. The 50 Hz notch filter is an active filter with a unity gain operational amplifier at the output stage of the filter to reduce loading effect. The simulation's result of the notch filter frequency response is shown in Figure 4.

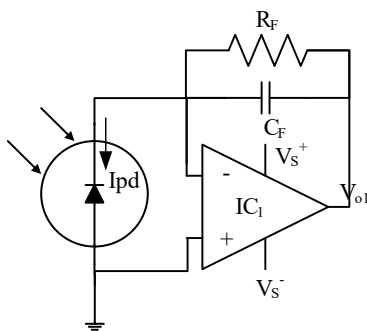

Figure 2. Transimpedance amplifier

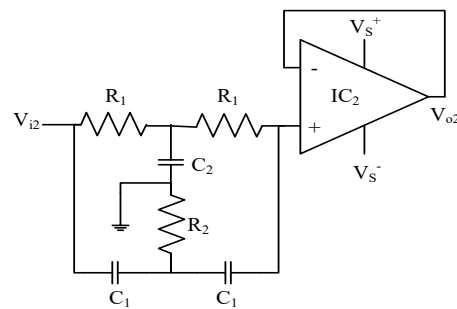

Figure 3. Notch filter

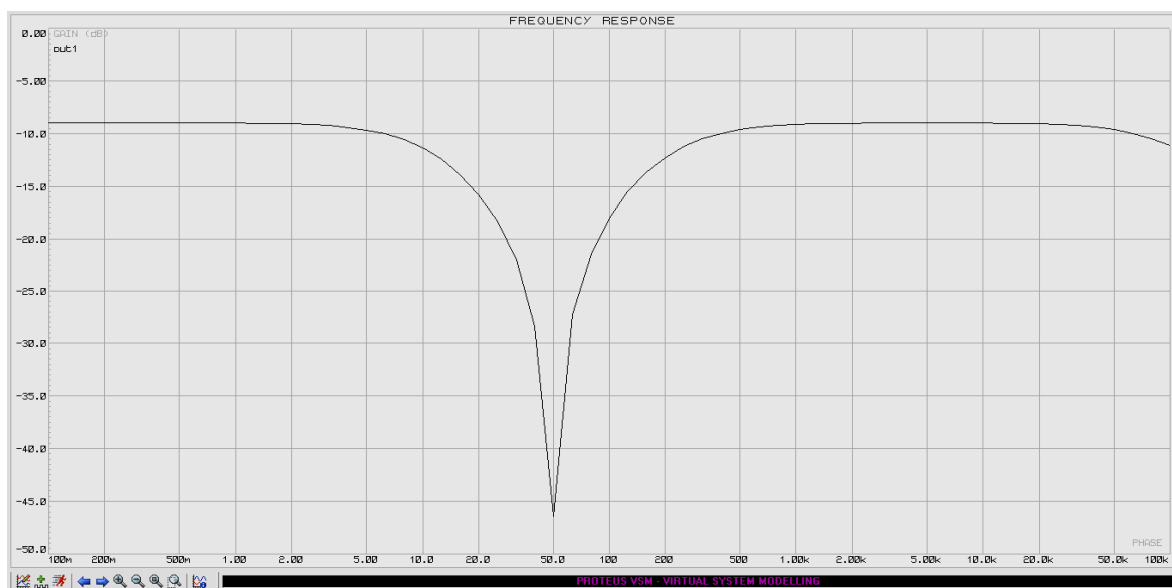

Figure 4. Notch filter frequency response

The active low pass filter circuit shown in Figure 5 is a two-stages and high gain operational amplifier which functions are to amplify and filter the appropriate voltage level from input signal [21]. The low pass filter frequency cut off is designed at 5 Hz and the frequency response is Butterworth approximation. The simulation result of the low pass filter frequency response is shown in Figure 6. In this experiment we measured the output voltages of the transimpedance amplifier (TIA) and the output voltages of the final stage amplifier after filters to observe the noises. We measured the voltages with a metrix digital voltmeter and a digital oscilloscope to observe the noises that occurred and we analyzed the stability of the sensor output voltages for one-hour measurement.

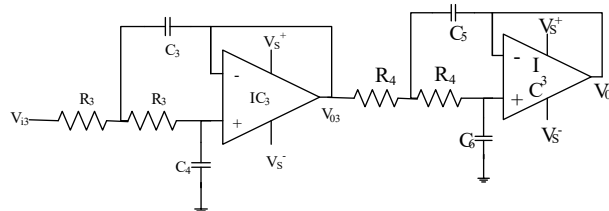

Figure 5. 4th order low pass filter [22]



Figure 6. 4th order low pass filter frequency response

The media between the LED and photodiode from the NIR sensor were air, water and 200 mg/dL glucose solution. The water and glucose solution were placed in an acrylic box with 0.5 cm thickness, 5 cm height and 5 cm width as shown in Figure 7. Aqueous optical paths of 5 mm are required to measure clinically relevant concentrations of glucose in the first-overtone region. All of the tested sites met this requirement [23]. The room temperature was constantly maintained at 27° C and the supply voltage was constantly maintained at 5.08 volts.

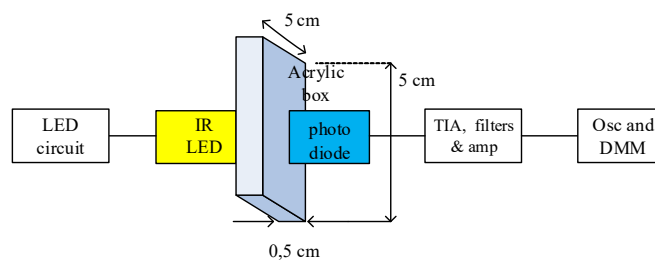

Figure 7. The experiment set up

The first experiment was conducted on the 6th floor of building E, in a laboratory room that near a power transformer for about 100 meters distance from the building (room A). The laboratory's windows were transparent glass. The second experiment was conducted in a classroom on the 6th floor of building E lit by fluorescent lamps and near a power transformer for about 50 meters distance from the building (room B). This room's windows were covered by multiplex boards. The third experiment was conducted in an office room on the 12th floor of building M (room C) with transparent glass windows.

The LED circuit drove the IR LED to emitted NIR light. After passing through media in an acrylic box, the photodiode sensor received the NIR light and a transimpedance amplifier (TIA) converted the current from the sensor to voltage. Filters were used to eliminate the low and high frequency noises. After the final amplifier the output voltage was measured with a digital multimeter. In this experiment we measured the output voltage with air, water and glucose solution media for one hour to know the stability of the output voltage. For one-hour measurement we expected a flat linier trend line in voltage versus time graph.

3. RESULTS AND ANALYSIS

The experiment result of the sensor output voltages in three different rooms are shown in Figures 8-10 and Table 1. The output voltages were recorded every five minutes within one hour. We measured the output voltages with air media between NIR LED and photodiode at 9:35 to 10:35 AM, with water media at 10:40 to 11:40 AM and with glucose solution media at 13:40 to 14:40 PM on different days for each room. Since the transmitted signal was direct current signal, the received signal should be direct current signal too.

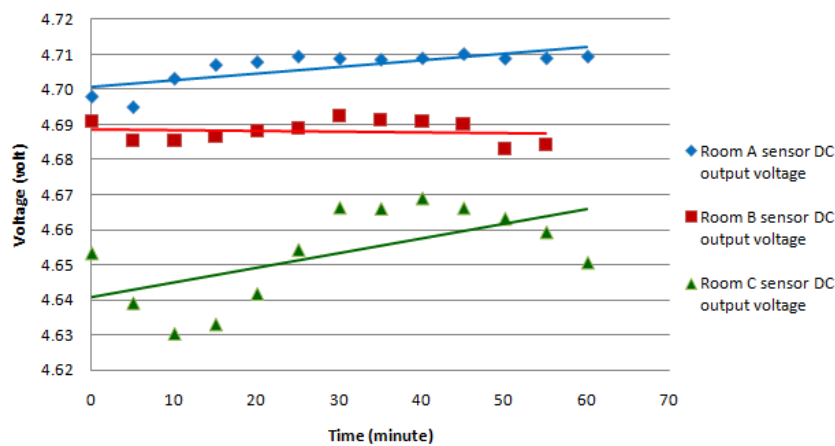

Figure 8. Room A, B and C sensor output voltages with air media

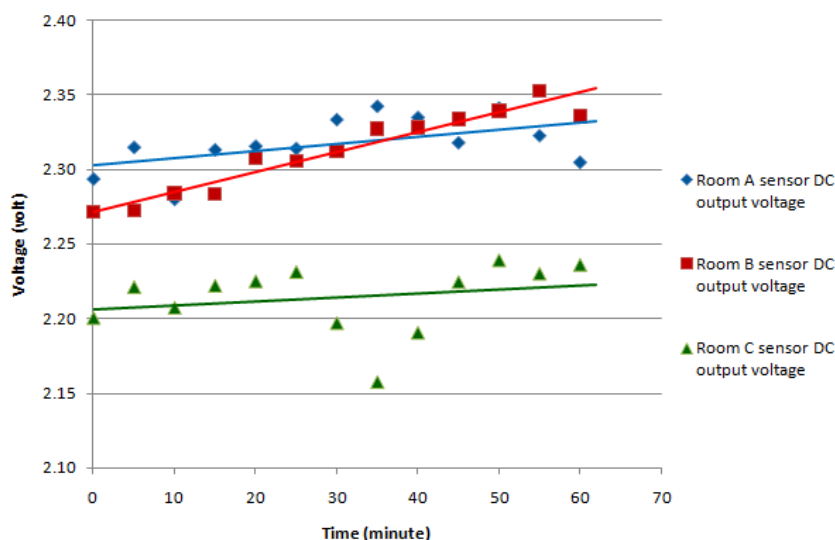

Figure 9. Room A, B and C sensor output voltages with water media

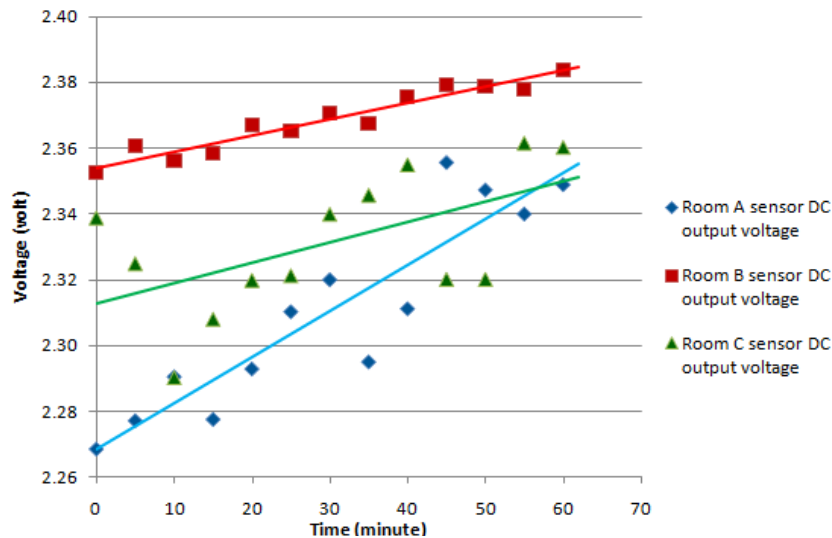

Figure 10. Room A, B and C sensor output voltages with glucose solution media

Table 1. TIA and sensor average output voltages for room A, B, and C

Media	Room A				Room B				Room C			
	TIA Vout [V]		Sensor Vout [V]		TIA Vout [V]		Sensor Vout [V]		TIA Vout [V]		Sensor Vout [V]	
	V_{DC}	V_{eff}	V_{DC}	V_{eff}	V_{DC}	V_{eff}	V_{DC}	V_{eff}	V_{DC}	V_{eff}	V_{DC}	V_{eff}
Air	3.7094	0.0000	4.7064	0.0000	3.6895	0.0000	4.6878	0.0000	3.6503	0.0000	4.6533	0.0000
Water	1.5868	0.0369	2.3173	0.0000	1.4984	0.0675	2.3116	0.0000	1.4732	0.0780	2.2140	0.0000
Glucose	1.5179	0.0739	2.3104	0.0000	1.5587	0.0690	2.3687	0.0000	1.5484	0.0775	2.3313	0.0000

As seen in Figure 8 with air media between the NIR LED and photodiode, the sensor output voltages from room A and B were higher and more stable than the voltages in room C. Room C was the room which received most sunlight. As seen from room A and B, most of the measured voltages were closed to linier trend line but in room C most of the measured voltages were far from linier trend line. The red linier trend line had the most flat slope and it meant that the measured voltages in room B were the most stable compared to the other rooms. The sensor output voltages tended to increase over time for each room from 10 mV to 40 mV.

As seen in Figure 9, the sensor output voltages from room A and B were higher and more stable than the voltages in room C, but the voltage stability was worse than with air media. The sensor output voltages tended to increase over time for each room with water media from 40 mV to 90 mV. As seen from room A, most of the measured voltages were closed to linier trend line but in room C most of the measured voltages were far from linier trend line. The blue linier trend line had the most flat slope but most of the measured voltages were far from the blue linier trend line. The voltage stability of room B was better than the other rooms. Room B was the room without window, sunlight did not interfere the measurements. As seen from Figure 10, the sensor output voltages from room B were higher and more stable compared to voltages in room A and C. The voltages tended to increase over time for each room with glucose solution media from 30 mV to 80 mV.

With air, water and glucose solution media the sensor output voltages tend to increase time by time, we suspected this was caused by noises in the photodiode components. From this experiment it can be seen that the measurement in room B with covered windows produced the most stable output voltages. The TIA and sensor average output voltages for room A, B and C is shown in Table 1. The first row of Table 1 showed that with air media, there was no measured effective voltage on the TIA and sensor output voltages. It meant that noises did not appear with air media for the three rooms. Air media did not absorb the NIR light from the NIR LED and in these experiments the DC output voltages from room A were higher than room B and C. The sensor average output voltage for the three rooms with air media was 4.6825 V. The second row of Table 1 showed that with water media, there were effective voltages on the TIA output voltages; it means that noises did appear with water media for the three rooms. The effective output voltages were the 50 Hz interference from the main power supply [24]. High frequency noises also appeared on the oscilloscope with very small voltage. After passing through the filters, the effective output voltages from the sensor were

reduced to zero. These sensor DC output voltages from the three rooms were lower almost half of the output voltages from air media. This result was consistent with our previous result [25]. Water absorbed NIR light and caused noises [26]. The sensor average output voltage for the three rooms with water media was 2.2809 V. The third row of Table 1 showed that with 200 mg/dL glucose solution media, there were effective voltages on the TIA output which meant noises did appear with glucose solution media for the three rooms. After passing through the filter the effective output voltages from the sensor were reduced to zero. The effective output voltages were a bit higher than the effective voltages with water media for room A and B; it meant that noises with glucose solution were higher than with water media [25]. The sensor average output voltage for the three rooms with glucose solution media was 2.3368 V. There was voltage difference between sensor average output voltage with water and glucose solution media from the three rooms and it could be concluded that the sensor had the potential as a blood glucose level meter.

4. CONCLUSION

In order to find out the effect of noises on NIR sensor, we studied noise sources in measuring glucose level with NIR sensor over time and measured the output voltage of the sensor in three different conditions with three different media between the light source and the sensor. From Table 1 can be seen that the filters reduced the effective output voltages to zero and it meant that the 50 Hz and high frequency noises could be removed with filters. The stability of the measurement output voltages from the three different places depended on the environmental conditions especially sunlight. The sensor output voltages of the 3-room tended to increase over time and we suspected it was from the noises in the photodiode component. Hence, this sensor can only be used in a short time and suitable only in a room without sunlight. In comparison with the other researches generally did not count on the sunlight effect. Based on the data presented on Table 1, there was voltage difference between average sensor output voltage with water media and average sensor output voltage with glucose solution media from room A, B and C. It could be concluded that the sensor had the potential as a blood glucose level meter. In our future research, we target to put the photodiode on an ear clip to be applied to an earlobe, process the sensor output signal, and develop software to display the measurement result on a smartphone.

ACKNOWLEDGMENT

We would like to express our gratitude to Trisakti University and DRPM, Ministry of Research, Technology and Higher Education of the Republic of Indonesia, Grant Number 201/A/LPT/USAKTI/V/2019, for funding this research.

REFERENCES

- [1] WHO, "Global Report on Diabetes," World Health Organization, 2016.
- [2] International Diabetes Federation, "IDF Diabetes Atlas, 8 ed," International Diabetes Federation, 2017.
- [3] K. J. Schlager, "Non-Invasive Near Infrared Measurement of Blood Analyte Concentrations," US4882492A. (Patent), 1988.
- [4] N. A. Salam, et al., "The Evolution of Non-invasive Blood Glucose Monitoring System for Personal Application," *Journal of Telecommunication, Electronics and Computer Engineering*, vol. 8, no. 1, pp. 59-65, 2016.
- [5] K. Maruo and M. Oka, "Method of Determining a Glucose Concentration in a Target by Using an Near Infrared Spectroscopy," US5957841A (Patent), 1998.
- [6] G. Acosta, et al., "Compact Apparatus for Non-Invasive Measurement of Glucose Through Near-Infrared Spectroscopy," CA2476421A1. (Patent), 2003, <https://patents.google.com/patent/CA2476421A1/en>
- [7] Z. Zhao and R. A. Myllyla, "Photoacoustic Blood Glucose and Skin Measurement Based on Optical Scattering Effect," *Proceedings of Saratov Fall Meeting*, vol. 4707, 2001.
- [8] R. D. Rosenthal, "Method for Providing Custom Calibration for Near-Infrared Instruments for Measurement of Blood Glucose," US5068536A. (Patent), 1991.
- [9] S. Haxha and J. Jhoja, "Optical Based Noninvasive Glucose Monitoring Sensor Prototype," *IEEE Photonics Journal*, vol. 8, no. 6, pp. 1-11, Dec 2016.
- [10] D. Sia, "Design of A Near Infrared Device for The Study of Glucose Concentration Measurements," *EE4B16 Electrical Engineering Biomedical Capstones, McMaster University*, 2010.
- [11] P. S. Reddy and K. Jyostna, "Development of Smart Insulin Device for Non Invasive Blood Glucose Level Monitoring," in *IEEE 7th International Advance Computing Conference*, pp. 516-519, 2017.
- [12] K. A. U. Menon, et al., "A Survey on Non-Invasive Blood Glucose Monitoring Using NIR," in *International Conference on Communication and Signal Processing*, India, 2013.
- [13] M. Pande and A. Joshi, "Non-Invasive Blood Glucose Measurement," *Proceeding of Int J ComputEng Res*, vol. 5, I. 4 pp. 26-28, 2015, http://www.ijceronline.com/papers/Vol5_issue4/E054026028.pdf
- [14] J. P. Coffin, et al., "Photodiode Detector with Integrated Noise Shielding," US6184521B1. (Patent), 1998.

- [15] J. Poeze, et al., "Interference Detector for Patient Monitor," US 8754776B2. (Patent), 2013.
- [16] M. Doğan and A. Tangel, "Shot Noise Measurement in PIN Photodiodes," *International Journal of Computing, Communication and Instrumentation Engg.*, vol. 3, no. 2, pp. 297-300, 2016.
- [17] C. D. Bobade and M. S. Patil, "Non-invasive Blood Glucose Level Monitoring System for Diabetic Patients using Near-Infrared Spectroscopy," *American Journal of Computer Science and Information Technology*, vol. 4, no. 01, pp. 1-8, 2016.
- [18] Jeon K. J., et al., "Comparison Between Transmittance and Reflectance Measurements in Glucose Determination Using Near Infrared Spectroscopy," *Journal of Biomedical Optics*, vol. 11, no. 1, 2006.
- [19] E. S. Julian, et al., "The Model of Near Infrared Sensor Output Voltage as a Function of Glucose Concentration in Solution," in *The 15th International Conference on Quality in Research (QIR)*, Bali, pp. 146-149, 2017.
- [20] K. Prawiroredjo, et al., "Noise reduction in near infrared-based glucose concentration measurement sensor," in *IOP Conference Series: Materials Science and Engineering*, vol. 532, Jun 2019.
- [21] Z. M. Yosuf, et al., "Design and Fabrication of Cost-Effective Heart-Rate Pulse Monitoring Sensor System," *TELKOMNIKA Telecommunication Computing Electronics and Control*, vol. 17, no. 5, pp. 2497-2504, Oct 2019.
- [22] B. G. Irianto, et al., "A low-cost electro-cardiograph machine equipped with sensitivity and paper speed option," *TELKOMNIKA Telecommunication Computing Electronics and Control*, vol. 17, no. 3, pp. 1275-1281, Jun 2019.
- [23] J. J. Burmeister and M. A. Arnold, "Evaluation of Measurement Sites for Noninvasive Blood Glucose Sensing with Near-Infrared Transmission Spectroscopy," *Clinical Chemistry*, vol. 45, no. 9, pp. 1621-1627, 1999.
- [24] A. C. M. van Rijn, et al., "High-Quality Recording of Bioelectric Events. Part 1 Interference Reduction, Theory and Practice," *Medical and Biological Engineering and Computer*, vol. 28, no. 5, pp. 389-397, Oct 1990.
- [25] K. Prawiroredjo and E. S. Julian, "Comparative study of 940 nm and 1450 nm near infrared sensor for glucose concentration monitoring," *TELKOMNIKA Telecommunication Computing Electronics and Control*, vol. 17, no. 2, pp. 981-985, Apr 2019.
- [26] K. Palmer and D. Williams, "Optical properties of water in the near infrared," *Journal of the Optical Society of America*, vol. 64, no. 8, pp. 1107-1110, Aug 1974.