

A proton-exchange membrane fuel cell and ultra-capacitor system model for stand-alone residential applications

Ibrahim Alhamrouni¹, Mohamed Salem², Awang Jusoh³, Tole Sutikno⁴

¹Electrical Engineering Section, British Malaysian Institute, University Kuala Lumpur (UniKL BMI), Kuala Lumpur, Malaysia

²School of Electrical and Electronic Engineering, Universiti Sains Malaysia, Nibong Tebal, Penang, Malaysia

³School of Electrical Engineering, Universiti Teknologi Malaysia, Skudai, Johor, Malaysia

⁴Department of Electrical Engineering, Faculty of Industrial Technology, Universitas Ahmad Dahlan, Yogyakarta, Indonesia

Article Info

Article history:

Received Aug 06, 2021

Revised Jul 24, 2022

Accepted Aug 01, 2022

Keywords:

Energy demands

Energy efficiency

PEM fuel cell

PEMFC

Stationary applications

Ultra-capacitor

ABSTRACT

Energy consumption by sector in Malaysia is rising significantly, especially for residential and commercial sectors, and is expected to continue to increase in the upcoming years. The existing power generated from a proton-exchange membrane fuel cell (PEMFC) system may be insufficient to sustain peak load demands during peak periods in stationary residential applications. The presence of an ultra-capacitor (UC) bank would be beneficial as a support as it can supply a large burst of power. The integration of PEMFC and UC has the potential to provide an effective way to supply power demands, has better energy efficiency, and is also economically friendly. In this research, we demonstrate a proposed combined PEMFC and UC bank that operates in parallel. A novel design methodology and dynamic model for both PEMFC and UC systems as energy sources have been developed for stand-alone residential applications. The simulation results are shown in Matlab Simulink. These results are based on mathematical and dynamic models of the system being shown.

This is an open access article under the [CC BY-SA](https://creativecommons.org/licenses/by-sa/4.0/) license.

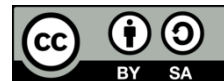

Corresponding Author:

Ibrahim Alhamrouni

Electrical Engineering Section, British Malaysian Institute, University Kuala Lumpur (UniKL BMI)

Gombak 53100, Kuala Lumpur, Malaysia

Email: ibrahim.mohamed@unikl.edu.my

1. INTRODUCTION

Energy consumption per capita has been increasing steadily in Malaysia over the past 40 years (1973–2016), which is from 0.395–1.793 Mtoe/Millions, and it is expected to rise in the upcoming years [1], [2]. The increase in energy consumption is affected by high population growth and is stated based on [3], [4]. Malaysia's current population is about 32 million. Aside from that, industry uses the most energy in Malaysia, followed by transportation, residential and commercial buildings, non-energy uses, and agriculture.

As for residential and commercial, the energy consumed by both sectors is rising, from 721 ktoe in the year 1978 to 8,729 ktoe in the year 2016. Hence, it shows that residential and commercial also consume a lot of energy as before and it will gradually increase as population growth is getting higher and housing areas are being developed rapidly in urban and rural areas, yet various solutions have been taken into consideration to overcome this issue [5], [6]. Due to the rise in demand for electricity, especially in urban areas, it is very important to have transmission networks that have the capability of delivering large amounts of electricity to consumers without encountering any problems [7], [8]. According to [9], [10], the estimation of demand depends on the load consumed by the client, in which case the information for the load profile aspect is owned by Tenaga Nasional Berhad (TNB) for different classes of consumers. The geographical location of Malaysia also affects the scope values of the demand profile to vary [11]. Table 1 shows the typical ranges of

maximum demand, including the residential areas in Malaysia. One of the reasons that has been considered for using this type of energy source, which is the fuel cell, is the environmental concerns [12]. The current source that is widely used in generating electricity is fossil fuels. This fossil fuel will have negative impacts on the environment and the world. Besides that, the future availability of fossil fuels is getting lower, yet technological developments require a lot of energy demand [13]. Thus, fuel cells become more practical to take over this source in the way that it is eco-friendly and assuring to be used to generate energy in the future [14].

Table 1. The range of maximum demand (M.D) for domestic consumer sub-classes or premises [6]

No	Type of premise	Rural (kW)	Suburban (kW)	Urban (kW)
1	Low-cost flats, single storey terrace, studio apartment (600 sq ft)	1.5	2	3
2	Double storey terrace or apartment	3	4	5
3	Single storey, semi-detached	3	5	7
4	Double storey, semi-detached	5	7	10
5	Single storey bungalow and three-room condominium	5	7	10
6	Double storey bungalow and luxury condominium	8	12	15

Fuel cells are commonly referred to as electrochemical devices that convert chemical energy into electrical energy [15], [16]. Proton/polymer exchange membrane fuel cell (PEMFC) is considered to be one of the most promising fuel cells that can be applied these days because of its ability to deliver high-power, high-energy densities, and more efficient and clean energy [17]. Years after years, the demand for energy is getting higher, especially for residential areas. Much research and discovery are being conducted on how to manage this issue and provide solutions that will have a smaller global impact.

According to previous studies, the power generated by this type of fuel cell may not be sufficient to meet the load demand requirements, especially during peak demand periods. Thus, it will lead to an increase in size and also a rising cost of the fuel cell [18], [19]. Besides that, for residential applications, the capacities of gravimetric and volumetric requirements are rigid [20]. Hence, the ultra-capacitor is used to be integrated with the fuel cell (FC) in parallel to support the existing stand-alone system. Apart from that, the ultra-capacitor (UC) bank that consists of several ultra-capacitors plays a role in storing energy while producing outstanding outputs compared to other typical capacitors [21], [22]. Besides that, the UC bank is economically practical as the cost of this component is very low matched with its high capabilities compared to other types of cells in the usage for stand-alone residential applications that might require a high demand for energy in peak periods.

A variety of techniques used for energy generation will be discussed with the presence of control strategies as they will contribute towards energy efficiency and peak power demands satisfactory for residential applications [23], [24]. For this work, proton exchange membrane fuel cells will be integrated with ultra-capacitors (UC) or supercapacitors to supply the stand-alone residential applications during non-peak periods as well as during peak demand periods. The PEMFC system is a type of fuel cell that can generate electricity by operating reversely with the principle of PEM electrolysis. Fuel cells are energy devices with a fixed charge that convert chemical energy into electrical energy [25], [26]. The main part of the PEMFC is the polymer-electrolyte membrane where ions and electron transfers are conducted and inhibited, respectively, from one electrode or catalyst layer to the other. Fuel oxidation will occur at the anode electrode layers while the reduction reaction takes place at the cathode. The electrical energy is created by consolidating oxygen (O_2) as well as hydrogen (H_2) [27], [28]. In the PEMFC, platinum is known as a metal with immense catalytic activity for both electrode responses [29]. The platinum catalyst acts to split the hydrogen molecule, while the splitting of the oxygen molecule is complicated as it will cause significant electricity losses. Hence, this catalyst (platinum) is considered the best alternative for this process.

An ultra-capacitor (UK) or (UC), also described as a supercapacitor, is an electrochemical device that is known to have a high value of capacitance compared to other types of capacitors. It tends to be 100 times more efficient than any capacitor in terms of energy per unit volume as well as the ability to store energy [30]. These fascinating and most commonly used devices usually get the most attention in small application systems. For satisfying peak power requirements, capacitors with higher power capabilities are used [31]. Ultra-capacitors have a greater life than the typical capacitor, which usually has only a few thousand cycles [32].

A parallel combination of polymer electrolyte fuel cells (PEFC) with supercapacitors has been proposed for the use of fuel cell vehicles (FCV) by [33]. This study aimed to facilitate the system of the fuel cell to work under peak power and to provide the brake energy system to recover. Supercapacitors are being used to combine with the PEFC in parallel without power electronic devices. This previous study showed that a parallel combination of the super capacitor (SC) and PEFC without electronic devices is possible and does not affect the consumption of fuel. Though it may seem reliable, the consumption will actually increase due

to the heavy drivetrain. There are some other methods that have been applied in order to provide electrical power for different stand-alone applications done by previous studies.

2. METHOD

All the techniques that will be used for the integration or combination of the PEMFC system and UC bank to be applied to stand-alone residential appliances will be described and explained in this section. This part of the section will concentrate on designing and integrating both energy sources to supply and satisfy the load demands in a stand-alone residential area inhabited by a family that has 3 adults and 4 children. The PEMFC is maintained to be the main source of the system to satisfy the load demands, yet a stand-alone source is not enough to supply the power during peak periods. Hence, UC bank is chosen to assist the PEMFC to satisfy the peak loads during peak periods. Different UC banks would have different product specifications and also output. Thus, BMOD0165 P048 C01 UC Bank is being selected to supply the power during the peak demand period. The UC bank also acts as energy storage and can be charged or discharged by itself or even by the main source, which is the PEMFC.

2.1. Dynamic model of PEMFC

There are three important elements for hydrogen molar flow, which are hydrogen input flow, hydrogen flow, and hydrogen output flow when the reaction takes place. At the same time, the pressure of the water partial as well as the oxygen partial can be achieved. The PEMFC system utilizes hydrogen as stated to power demand, and the reformer generates hydrogen repeatedly during operation as shown in Figure 1. During operational conditions, proportional integral (PI) control is used to supervise the hydrogen flow rate depending on the output power of the PEMFC system. To accomplish this feedback, the output of the FC current is seized to the input, transforming the hydrogen into molar form. Apart from that, by using a PI controller, the volume of hydrogen available from the reformer can be applied to control the methane flow rate. Meanwhile, PI controllers also have their own drawbacks, which are PI, sliding mode, and artificial neural network (ANN) based unified power flow controller (UPFC) control systems. All these controllers regulate the power perfectly when the power system is operating in a single operating mode. No one has checked to see if these controllers can handle any change in the way the power system works at different operating points.

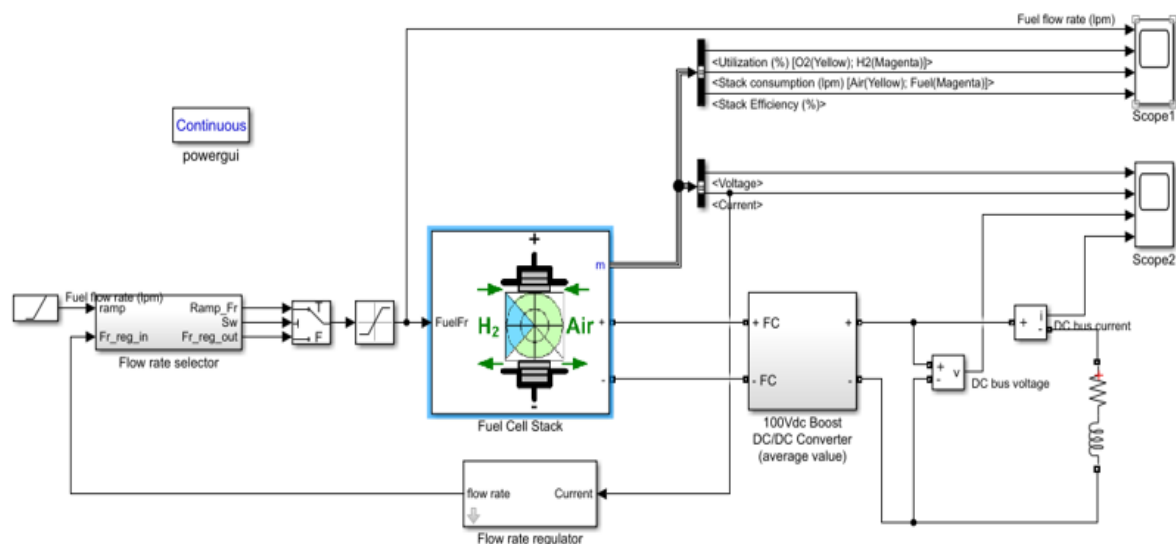

Figure 1. Model of PEM fuel cell stack

2.2. UC system model

The proposed work utilizes the ultra-capacitor or supercapacitor as an alternative energy source to supply and sustain the extra load required during peak periods. This will guarantee continuous supply to consumers and help to reduce the cost of electricity during peak hours and maximum demand. Figure 2 shows the model of the supercapacitor that is being designed using Matlab Simulink with all the expected

parameters. The model is designed based on parameters that are similar to the ultra-capacitor from Maxwell Technologies, which is BMOD0165 P048 C01. This supercapacitor has 18 series capacitors, and the rated capacitance of each capacitor is 165 F. The product specifications details are shown in Table 2.

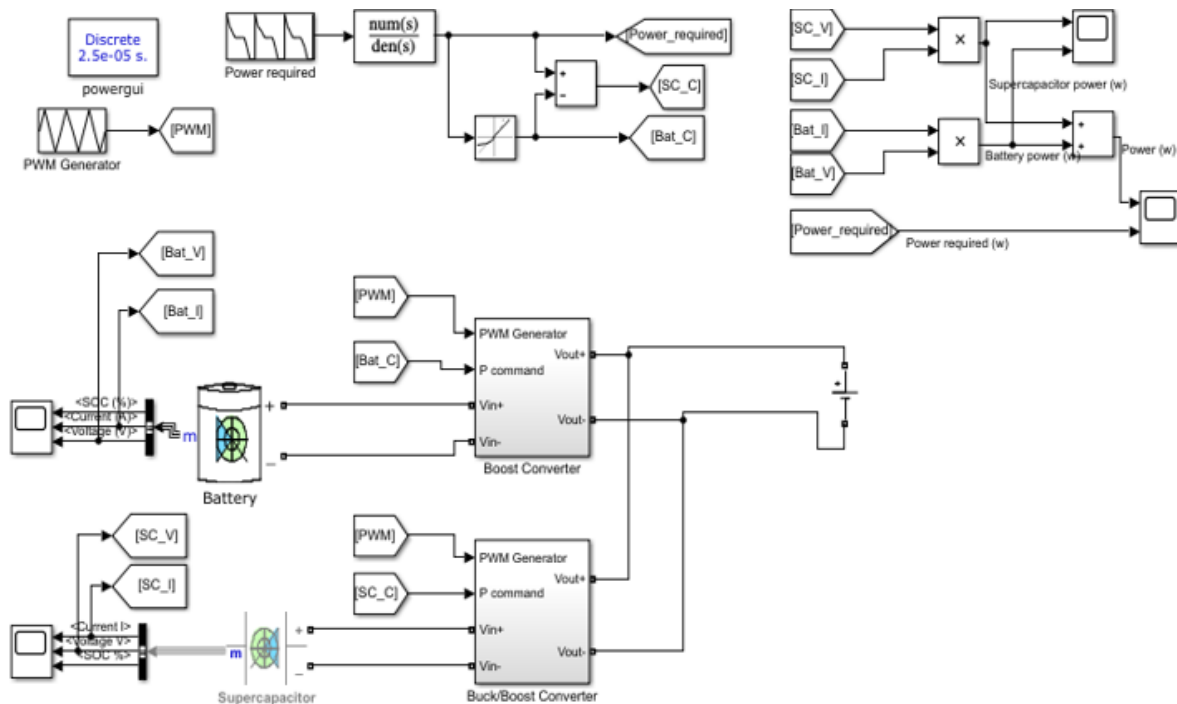

Figure 2. Model of supercapacitor

Table 2. Product specifications for BMOD0165 P048 C01 UC bank

No	Parameter	Specification
1	Electrical	BMOD0165 P048 C01
2	Rated capacitance	165 F
3	Minimum capacitance/maximum capacitance	165 F/200 F
4	Rated voltage	48 V
5	Absolute maximum voltage	51 V
6	Absolute maximum current	1,900 A
7	Leakage current at 25	5.2 mA
8	Capacitance of individual cell	3,000 F
9	Stored energy, individual cell	3 Wh
10	Number of cells	18
11	Minimum operating temperature	-40
12	Maximum operating temperature	65

To supply effective specific energy for a prescribed load, diversified configurations of UC banks can be used. In practical applications, the desired amount of terminal voltage, electrical energy, as well as the capacitance of the UC storage system can be constructed using various numbers of UCs in series and parallel connections as shown in Figure 3. The number of capacitors can be driven by the terminal voltage that must be connected in series, which is used to build a bank. Apart from that, the number of capacitors in parallel connection is influenced by the total capacitance. This figure also illustrates the example of how several UC units can be combined to form a UC bank that is sufficient for satisfying the peak load demand. In Matlab Simulink, an example of how the ultra-capacitor or supercapacitor bank model can be set up has been made.

2.3. Combined PEMFC and UC system

In this section, the integration between PEMFC and UC Bank will be presented to prove the compatibility of both systems to satisfy the stand-alone residential loads. The integration of the UC system can be achieved either with the presence of a power electronic converter or without it through a parallel

connection. Also, using both systems together could work with a DC bus with a voltage of less than 50 V for low voltage applications.

Figure 4 illustrates the direct integration of the PEMFC system with the UC bank by using a power diode. The reason for using the power diode is to obstruct reverse current flow from getting into the FC system. The stand-alone residential applications, which are a state when energy demand is low and only a small amount of energy is needed, and b when energy demand is high and the load needs more energy than what the PEMFC can provide.

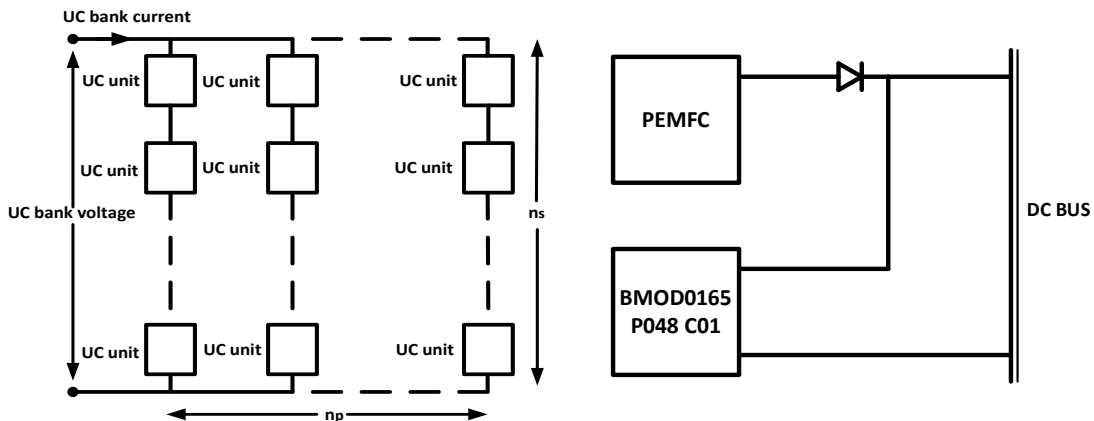

Figure 3. Example UCs in series and parallel connection Figure 4. Circuit diagram for overall system

The total resistance between PEMFC and the UC bank will determine the power sharing within both systems. In a nutshell, here is a summary of the main management planning for the integrated system:

- During non-peak periods (< 8 kW), the PEMFC system supplies its maximum power until it reaches its limit, and the remaining extra power generated is used to charge the UC bank. The terminal voltage of overall load demands determines the state of charging or discharging of the ultra-capacitor bank system.
- During peak periods (≥ 8 kW), when peak load demands are required, the PEMFC system produces the rated power again and discharges the UC bank to fulfill the remaining power that the PEMFC system cannot satisfy.
- In the PEMFC system, UC bank can supply short-term power interruptions.
- The other benefit of the UC bank is that it keeps the system from charging too much or too little.

3. RESULTS AND DISCUSSION

This section highlights the results that have been obtained from the analysis of data to attain and accomplish the objectives of this work. The PEMFC and ultra-capacitor models used in this work have been designed and embedded in Matlab Simulink based on specific parameters. Apart from that, the model of the fuel cell is completed using the DC-DC boost converter and PI/PID controller as the control strategies mentioned in the previous sections. In preparation for designing and completing the model of PEMFC as well as the ultra-capacitor, all the parameters and characteristics of the model itself have been considered to ensure the ideal version of this research will be done successfully. Some of the research has been reviewed and discussed in the previous sections. So, the dynamic behavior of each element must be taken into account and shown to make sure that power flows as efficiently as possible.

The simulation result obtained in Figure 5 shows the total amount of power that can be delivered to supply the stand-alone residential applications during the non-peak period. When non-peak demands occur, the power required is only 7 kW, and this can be satisfied by using the stand-alone PEMFC itself as the main source. This is because the PEMFC can generate power that varies from 7.008 kW and can reach up to a maximum value of power, which is 8.325 kW. Hence, the simulation successfully shows the PEMFC can withstand the load during non-peak periods. The remaining extra power generated can be stored in a UC bank if it is not required by the load.

This section proves that PEMFC, which is the main source, can satisfy the baseload during non-peak periods (7 kW). Despite this successful event, the power that has been generated by the PEMFC does not satisfy the peak load demands during peak periods. This is because, during peak periods, the power demand is

high as it can reach up to 9.5 kW and is expected to increase to 10 kW. Since this is the case, ultra-capacitors or supercapacitors can be used as a backup power source to provide the extra power needed during peak times.

As illustrated in Figure 6, the supercapacitor is capable of generating additional power of about 2 kW. This power is used to support and also to provide additional energy towards the main source (PEMFC) to satisfy the peak load demands of the stand-alone residential applications during the peak period. Since the PEMFC can't get that energy, the supercapacitor will store the rest of the energy that isn't being used to meet the demand.

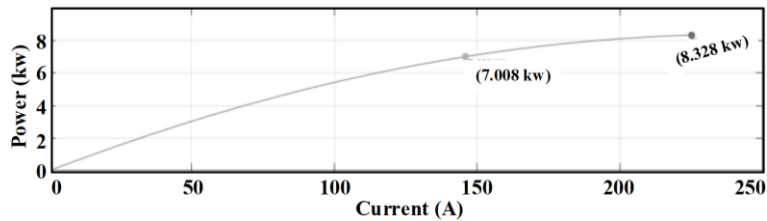

Figure 5. PEMFC power (kW)

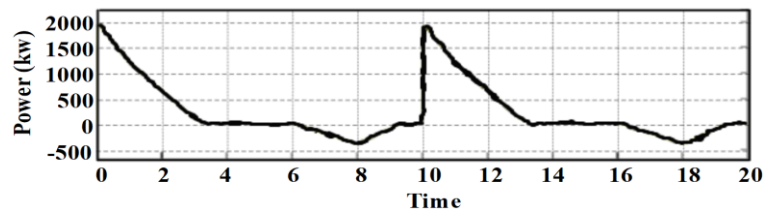

Figure 6. Supercapacitor power (kW)

This section explains the load profile of the electrical system for a stand-alone residential load that has been collected throughout a 24-hour period as shown in Figure 7. This section also introduces a software or application which has been used to gather all information and data about energy consumption before implementing the design of a combined PEMFC with UC bank to satisfy the load demands, especially during the peak periods, which are in need of extra power to be sustained. Most single-family homes have a standard smart meter reader installed, which is used to track how much energy is used.

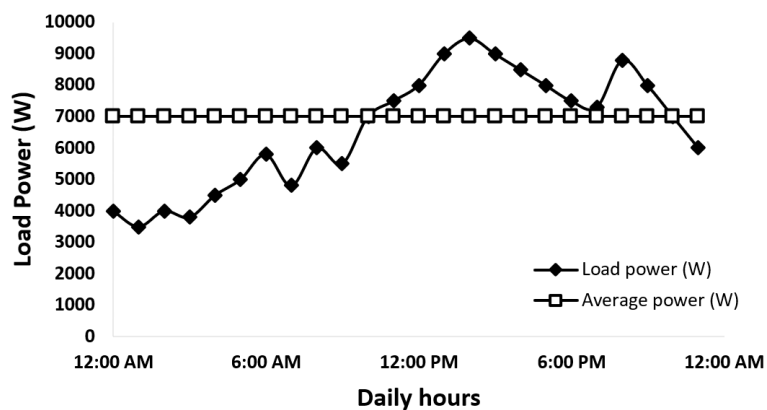

Figure 7. Load profile of stand-alone residential applications

Figure 8 proves that the power generated by the combined PEMFC and UC bank is higher than the power required by the load during the 24-hour period. Each time the load demands a specific amount of power, the system will generate slightly more power to satisfy the load. When the load demand reaches peak periods, for example, during peak hours, the demand for energy will increase more than the limit of the

PEMFC would generate. This is where the UC bank will function to supply the remaining power required by the load. During this situation, the discharge current of the UC bank is at its peak and the terminal voltage of the system drops extremely. Thus, this system will switch to the UC bank beside the PEMFC when there is a shortage of power. Hence, it is a proof of success that the total power generated by the combined system satisfies the load of stand-alone residential applications even during peak load demands. In addition, for improvement, distribution generation (DG) could be used as well in enhancing power transmission for this type of load, but it may not be necessary as DG systems are used for larger applications. DG is not only capable of solving most of the network's expansion problems but also able to reduce power loss, enhance the reliability of the system, and improve the voltage level. DG also plays a big role in modern power systems since it is capable of reducing the line losses and improving the voltage level, which will significantly improve the power quality and efficiency of power transmitting and distributing from one point to another point. This system can also be implemented for larger stand-alone residential areas for future recommendations.

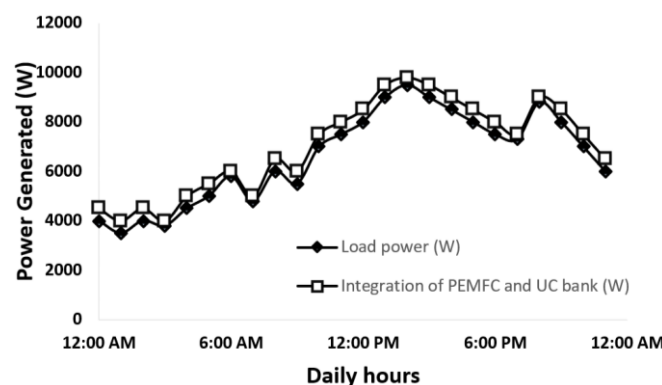

Figure 8. Load profile real power and generated power from integrated PEMFC and UC bank

4. CONCLUSION

A combined PEMFC and ultra-capacitor UC or supercapacitor bank was designed and modeled to meet the load demands of stand-alone residential applications measured in kilowatts (kW) during non-peak and peak times. The PEMFC and ultracapacitor were combined into parallel connections to ensure that electricity could be successfully delivered to residential load applications while also exhibiting good load performance. Without the availability of a UC bank, the PEMFC system must supply the additional power necessary during peak periods, which causes various issues such as an increase in the size and expense of the PEMFC system itself, as well as a reduction in system efficiency. The benefits of merging both PEMFC and UC bank sources can lengthen the lifespan of a PEMFC system rather than employing a stand-alone FC system and lower maintenance costs. However, the proposed model can be applied for a variety of load profiles that include various transients and short-term interruptions. It can also be employed in a variety of applications, including portable devices, heavy vehicles, and aerospace.

ACKNOWLEDGEMENTS

The authors would like to express their gratitude to the following institutions for their support of this joint research project: the University of Kuala Lumpur (UniKL BMI), Universiti Sains Malaysia, Universiti Teknologi Malaysia, and Universitas Ahmad Dahlan.



REFERENCES

- [1] Y. Zahraoui, I. Alhamrouni, S. Mekhilef, M. R. B. Khan, B. P. Hayes, and M. Ahmed, "A novel approach for sizing battery storage system for enhancing resilience ability of a microgrid," *International Transaction Electrical Energy Systems*, vol. 31, no. 12, 2021, doi: 10.1002/2050-7038.13142.
- [2] U. Wethal, "Practices, provision and protest: Power outages in rural Norwegian households," *Energy Research and Social Science*, vol. 62, 2020, doi: 10.1016/j.erss.2019.101388.
- [3] M. Amini, A. Khorsandi, B. Vahidi, S. H. Hosseinian, and A. Malakmahmoudi, "Optimal sizing of battery energy storage in a microgrid considering capacity degradation and replacement year," *Electric Power Systems Research*, vol. 195, 2021, doi: 10.1016/j.epsr.2021.107170.



- [4] U. T. Salman, F. S. Al-Ismail, and M. Khalid, "Optimal sizing of battery energy storage for grid-connected and isolated wind-penetrated microgrid," *IEEE Access*, vol. 8, pp. 91129–91138, 2020, doi: 10.1109/ACCESS.2020.2992654.
- [5] K. Gong, X. Wang, C. Jiang, M. Shahidehpour, X. Liu, and Z. Zhu, "Security-Constrained Optimal Sizing and Siting of BESS in Hybrid AC/DC Microgrid Considering Post-Contingency Corrective Rescheduling," *IEEE Transactions on Sustainable Energy*, vol. 12, no. 4, pp. 2110–2122, 2021, doi: 10.1109/TSTE.2021.3080707.
- [6] Tenaga Nasional Berhad, *Electricity Supply Application Handbook*, Third (3rd) Edition, Malaysia: Tenaga Nasional, 1949. [Online]. Available: https://www.tnb.com.my/assets/files/2022_ESAH_3.1.pdf
- [7] H. R. Esmailian, R. Fadaeinedjad and G. Moschopoulos, "Dynamic operation and control of a stand-alone PEM fuel cell system," *2014 IEEE Applied Power Electronics Conference and Exposition - APEC 2014*, 2014, pp. 3378–3384, doi: 10.1109/APEC.2014.6803792.
- [8] K. Scott and A. K. Shukla, "Polymer electrolyte membrane fuel cells: Principles and advances," *Reviews in Environmental Science and Biotechnology*, vol. 3, pp. 273–280, 2004, doi: 10.1007/s11157-004-6884-z.
- [9] L. Gao, Z. Jiang, R. A. Dougal, "An actively controlled fuel cell/battery hybrid to meet pulsed power demands," *Journal of Power Sources*, vol. 130, no. 1-2, pp. 202–207, 2004, doi: 10.1016/j.jpowsour.2003.12.052.
- [10] P. J. R. Pinto, V. R. Fernandes, A. M. F. R. Pinto, and C. M. Rangel, "Analysis of a Stand-Alone Residential PEMFC Power System with Sodium Borohydride as Hydrogen Source," in *4th International Seminar on Advances in Hydrogen Energy Technologies: Opportunities and Challenges in a Hydrogen Economy*, 2011, pp. 1–7. [Online]. Available: http://repositorio.lneg.pt/bitstream/10400.9/1470/1/AHET_FCM_%2032Pinto.pdf
- [11] W. Turki and A. K. Derbeli, "Modeling and control of a stand-alone PEMFC for AC load-PMSM application," *2017 International Conference on Green Energy Conversion Systems (GECS)*, 2017, pp. 1-6, doi: 10.1109/GECS.2017.8066208.
- [12] I. Alhamrouni, M. Iskander, M. Salem, L. J. Awalin, A. Jusoh, and T. Sutikno, "Application of inductive coupling for wireless power transfer," *International Journal of Power Electronics and Drive Systems*, vol. 11, no. 3, pp. 1109–1116, 2020, doi: 10.11591/ijpeds.v11.i3.pp1109-1116.
- [13] J. Ramakrishnan and P. P. Vaidya, "Measurement of parameters of ultracapacitor," *2017 2nd IEEE International Conference on Recent Trends in Electronics, Information & Communication Technology (RTEICT)*, 2017, pp. 1831–1835, doi: 10.1109/RTEICT.2017.8256915.
- [14] Y. Ohki, "Commencement of operation of the world's largest storage battery facility [News from Japan]," in *IEEE Electrical Insulation Magazine*, vol. 33, no. 1, pp. 59–61, 2017, doi: 10.1109/MEI.2017.7804322.
- [15] A. Fathy, K. Kaaniche, and T. M. Alanazi, "Recent Approach Based Social Spider Optimizer for Optimal Sizing of Hybrid PV/Wind/Battery/Diesel Integrated Microgrid in Aljouf Region," in *IEEE Access*, vol. 8, pp. 57630–57645, 2020, doi: 10.1109/ACCESS.2020.2982805.
- [16] S. D. L. Torre, J. M. G. -González, J. A. Aguado, and S. Martín, "Optimal battery sizing considering degradation for renewable energy integration," *IET Renewable Power Generation*, vol. 13, no. 4, pp. 572–577, 2019, doi: 10.1049/iet-rpg.2018.5489.
- [17] M. Papra, F. N. Büchi, and R. Kötz, "Investigating the Dynamics of a Direct Parallel Combination of Supercapacitors and Polymer Electrolyte Fuel Cells," *Fuel Cells*, vol. 10, no. 5, pp. 873–878, 2010, doi: 10.1002/fuce.200900197.
- [18] A. A. Hafez, A. Y. Abdelaziz, M. A. Hendy, and A. F. M. Ali, "Optimal sizing of off-line microgrid via hybrid multi-objective simulated annealing particle swarm optimizer," *Computers and Electrical Engineering*, vol. 94, 2021, doi: 10.1016/j.compeleceng.2021.107294.
- [19] S. A. P. Kani, P. Wild, and T. K. Saha, "Improving Predictability of Renewable Generation Through Optimal Battery Sizing," in *IEEE Transactions on Sustainable Energy*, vol. 11, no. 1, pp. 37–47, 2020, doi: 10.1109/TSTE.2018.2883424.
- [20] I. Alhamrouni, N. Zainuddin, M. Salem, N. H. A. Rahman, and L. Awalin, "Design of single-phase inverter for photovoltaic application controlled with sinusoidal pulse width modulation," *Indonesian Journal of Electrical Engineering and Computer Science (IJECS)*, vol. 15, no. 2, pp. 620–630, 2019, doi: 10.11591/ijeecs.v15.i2.pp620-630.
- [21] S. Sharma, S. Bhattacharjee, and A. Bhattacharya, "Grey wolf optimisation for optimal sizing of battery energy storage device to minimise operation cost of microgrid," *IET Generation, Transmission and Distribution*, vol. 10, no. 3, pp. 625–637, 2016, doi: 10.1049/iet-gtd.2015.0429.
- [22] Y. Zahraoui *et al.*, "Energy Management System in Microgrids: A Comprehensive Review," *Sustainability*, vol. 13, no. 19, 2021, doi: 10.3390/su131910492.
- [23] S. Sukumar, H. Mokhlis, S. Mekhilef, K. Naidu, and M. Karimi, "Mix-mode energy management strategy and battery sizing for economic operation of grid-tied microgrid," *Energy*, vol. 118, pp. 1322–1333, 2017, doi: 10.1016/j.energy.2016.11.018.
- [24] P. Harsha and M. Dahleh, "Optimal management and sizing of energy storage under dynamic pricing for the efficient integration of renewable energy," *IEEE Transactions on Power Systems*, vol. 30, no. 3, pp. 1164–1181, 2015, doi: 10.1109/TPWRS.2014.2344859.
- [25] M. Zolfaghari, N. Ghaffarzadeh, and A. J. Ardakani, "Optimal sizing of battery energy storage systems in off-grid micro grids using convex optimization," *Journal Energy Storage*, vol. 23, pp. 44–56, 2019, doi: 10.1016/j.est.2019.02.027.
- [26] L. Xu, X. Ruan, C. Mao, B. Zhang, and Y. Luo, "An improved optimal sizing method for wind-solar-battery hybrid power system," *IEEE Transactions on Sustainable Energy*, vol. 4, no. 3, pp. 774–785, 2013, doi: 10.1109/TSTE.2012.2228509.
- [27] B. Ismail, M. M. Naain, N. I. A. Wahab, L. J. Awalin, I. Alhamrouni, and M. F. A. Rahim, "Optimal placement of DSTATCOM in distribution network based on load flow and voltage stability indices studies," *2017 International Conference on Engineering Technology and Technopreneurship (ICE2T)*, 2017, pp. 1-6, doi: 10.1109/ICE2T.2017.8215973.
- [28] N. Mehmood and N. Arshad, "Towards Developing a Large Distributed Energy Storage using a Weighted Batteries Scheduling Scheme," *IEEE Access*, vol. 8, pp. 210733–210749, 2020, doi: 10.1109/access.2020.3039924.
- [29] C. Zhang, Y. -L. Wei, P. -F. Cao, and M. -C. Lin, "Energy storage system: Current studies on batteries and power condition system," *Renewable and Sustainable Energy Reviews*, vol. 82, pp. 3091–3106, 2018, doi: 10.1016/j.rser.2017.10.030.
- [30] B. K. Tan, N. M. L. Tan, and A. K. Ramasamy, "Design of a battery-ultracapacitor hybrid energy-storage system with power flow control for an electric vehicle," *International Journal of Power Electronics and Drive Systems*, vol. 9, no. 1, pp. 286–296, 2018, doi: 10.11591/ijpeds.v9.i1.pp286-296.
- [31] I. N. Moghaddam, B. H. Chowdhury, and S. Mohajeryami, "Predictive Operation and Optimal Sizing of Battery Energy Storage with High Wind Energy Penetration," *IEEE Transactions on Industrial Electronics*, vol. 65, no. 8, pp. 6686–6695, 2018, doi: 10.1109/TIE.2017.2774732.
- [32] I. Alhamrouni, A. Khairuddin, M. Salem, and A. Alnajjar, "Review on Transmission Expansion Planning Models," *Applied Mechanics and Materials*, vol. 818, pp. 129–133, 2016, doi: 10.4028/www.scientific.net/AMM.818.129.
- [33] D. Cerrai, M. Koukoulou, P. Watson, and E. N. Anagnostou, "Outage prediction models for snow and ice storms," *Sustainable Energy, Grids and Networks*, vol. 21, 2020, doi: 10.1016/j.segan.2019.100294.

BIOGRAPHIES OF AUTHORS





Ibrahim Alhamrouni    received his B.Eng. degree in electrical engineering from Elmergib University, Al Khums, Libya, in 2008. I received my M.Sc. degree in electrical power engineering from Universiti Tun Hussein Onn Malaysia (UTHM), Batu Pahat, Johor, Malaysia, in 2011. In 2015, he was awarded his Ph.D. degree by the Faculty of Electrical Engineering, Universiti Teknologi Malaysia (UTM), Malaysia. Currently, he is a senior lecturer and researcher at the British Malaysian Institute, University of Kuala Lumpur, Malaysia. His research interests include power system planning and operation; deregulation and restructuring of power systems; and power line maintenance. He's currently working on micro-grid technologies and the application of power electronics in power systems. He can be contacted at email: ibrahim.mohamed@unikl.edu.my.





Mohamed Salem    received his B.Eng. in electrical and power engineering from Elmergib University, Libya, in 2008. In 2011, he received his M.Sc. in electrical engineering from (UTHM), Malaysia. In August 2017, he was awarded his Ph.D. degree by the Department of Power Engineering, Faculty of Electrical Engineering, Universiti Teknologi Malaysia. He is a member of IEEE and a registered graduate engineer (BEM) in the electrical track. Currently, he has been a senior lecturer at the School of Electrical and Electronic Engineering, Universiti Sains Malaysia, Penang, Malaysia since July 2018. He has authored and co-authored a number of well-recognized journals and conference papers. His research interests are in DC-DC converters, renewable energy applications, and control of power electronic systems. He can be contacted at email: salemm@usm.my.



Awang Jusoh    was born in Terengganu, Malaysia in 1964. He received his B.Eng. degree from Brighton Poly-technic, U.K., in 1988. He obtained his M.Sc. and Ph.D. degrees from the University of Birmingham, U.K., in 1995 and 2004, respectively. He is currently an Associate Professor in the Department of Power Engineering, Faculty of Electrical Engineering, Universiti Teknologi Malaysia (UTM), Johor, Malaysia. His research interests are in DC-DC converters, renewable energy, and control of power electronics systems. He can be contacted at email: awang@fke.utm.my.



Tole Sutikno    is a Lecturer in the Electrical Engineering Department at the Universitas Ahmad Dahlan (UAD), Yogyakarta, Indonesia. He received his B.Eng., M.Eng., and Ph.D. degrees in Electrical Engineering from Universitas Diponegoro, Universitas Gadjah Mada, and Universiti Teknologi Malaysia, in 1999, 2004, and 2016, respectively. He has been an Associate Professor at UAD, Yogyakarta, Indonesia since 2008. Since 2016, he has led the Embedded Systems and Power Electronics Research Group. His research interests include the fields of industrial applications, industrial electronics, industrial informatics, power electronics, motor drives, renewable energy, FPGA applications, embedded systems, image processing, artificial intelligence, intelligent control, digital design, and digital library. He can be contacted at email: tole@te.uad.ac.id.