

## Performance Analysis of a PV/FC Hybrid System for Generating Electricity in Iraq's Remote Areas

Z. Nawawi<sup>1</sup>, A.S. Aziz<sup>2</sup>, Z. Buntat<sup>2</sup>, M.A.B. Sidik<sup>\*1,2</sup>, H.J. Kareem<sup>2</sup>, A.Z. Abdulameer<sup>2</sup>,  
M.A.A. Aziz<sup>2</sup>, M.I. Jambak<sup>1</sup>, Y.Z. Arief<sup>2</sup>

<sup>1</sup>Department of Electrical Engineering, Faculty of Engineering, Universitas Sriwijaya,  
30662 Inderalaya Ogan Ilir, South Sumatera, Indonesia

<sup>2</sup>Institute of High Voltage and High Current (IVAT), Faculty of Electrical Engineering,  
Universiti Teknologi Malaysia, 81310 Johor Bahru, Johor, Malaysia

\*Corresponding author, e-mail: abubakar@unsri.ac.id

### Abstract

A reliable electrical energy supply is a prerequisite for improving the standard economic and quality of life levels in a country. As is the case in many countries, Iraq is home to a collection of remote villages. Since it is uneconomical to connect these villages to the existing grid, the installation of stand-alone electrical power generators has become common practice. As a result, diesel stand-alone power generators see widespread use in these remote locales, which, whilst fit for their intended purpose, unfortunately suffer from several drawbacks, including instability in regards to everyday oil prices and a number of environmental issues. The implementation of a PV/FC hybrid power system could be one potential alternative to help solve these problems. Therefore, this paper will present PV/FC system control strategies alongside information relating to the performance of such system components, based on a case study that was conducted in Al-Gowair, Iraq. This study is especially important in terms of envisioning the future energy supply needs of Iraq. The HOMER simulation results showed that by using the proposed control strategies and suggested components of a PV/FC system, it was able to produce a satisfactory outcome.

**Keywords:** photovoltaic, fuel cells, hybrid power system, remote area, diesel generator

Copyright © 2016 Universitas Ahmad Dahlan. All rights reserved.

### 1. Background

There are many remote villages that are located far away from the utility grid in Iraq. Connecting such villages to the existing grid is certainly both impractical and inefficient. Therefore, in order to fulfil the electrical energy demand in those particular villages, the installation of standalone generators is a normal practice in Iraq.

However petroleum costs keep increasing, with the fluctuations in price often being unpredictable. As such, the use of diesel as a fuel source for standalone generators in remote areas can no longer be considered reliable. In addition, since its consumption releases significant pollutants, such as CO<sub>2</sub>, CO, NO<sub>x</sub> and SO<sub>2</sub>, diesel is unfriendly to the environment [1, 2].

As a result, the best option for remote areas would be to install standalone electrical generators, which utilise a renewable energy supply. Under similar conditions, there are some renewable energy sources and technologies that are available for use, which have already been applied, as shown in Table 1.

Table 1. Applications of renewable energy in some countries

Country	Renewable energy applied	Capacity
Sine Moussa Abdou, Thiès region, Senegal [3]	PV-Wind turbine-Battery- Diesel generator	5.2 kWp PV array, 5 kW wind turbine, 120 kWh battery bank and a 8.5 kVA diesel genset
Kimprana-Mali [3]	PV- Battery- Diesel generator - local grid	72 kWp, PV array, 1185 kWh, 175 kVA diesel genset, 400 V DC, Sunny Mini Central
Conselice, Italy [4]	Palm oil	50 MWeI (engines) + 6 MWeI (steam turbine)
Angonia, Tete, Mozambique [5]	Hydropower	280 kW
Maguga Dam, Swaziland [6]	Hydropower	19.2 MW

One potential renewable energy source is a hybrid photovoltaic (PV) and fuel cell (FC) system. Regarding the green energy concept, these are both excellent renewable energy sources. PV/FC power plants have been successfully operated in many countries, including Germany, Italy, Finland, Japan, Spain, Saudi Arabia, Switzerland and the USA [7].

In Neunburg vorm Wald, Germany, the system consists of several different PV technologies that range in size from 6 kW<sub>p</sub> to 135 kW<sub>p</sub>. Other subsystems include DC/DC and DC/AC converters, DC and AC busbars as well as two electrolyzers of 111 kW<sub>e</sub> and 100 kW<sub>e</sub>, which are used to produce 47 m<sup>3</sup>/h of hydrogen, refrigerating units of 16.6 kW<sub>th</sub> and three fuel cells, i.e. (1) alkaline of 6.5 kW<sub>e</sub> and 42.2 kW<sub>th</sub>, (2) phosphoric acid of 79.3 kW<sub>e</sub> and 13.3kW<sub>th</sub>, and (3) PEM of 10 kW<sub>e</sub>. Similarly, the Ente Nazionale per le Energie Alternative (The ENEA Project) in Italy consists of a PV field of 5.6 kW<sub>p</sub>, a bipolar alkaline electrolyzer of 5 kW and a tank storage subsystem of 18 Nm<sup>3</sup>. The control system is based on a Programmable Logic Controller (PLC), which controls many variables such as the temperature of the electrolyzer, the range of the current, the conductivity of water and it has the ability to stop the system in emergency situations. The fuel cell size is a 3 kW PEM, operating at 72°C. The two aforementioned examples show that the cost of installing a PV/FC system is higher than the relative installation costs of a diesel generator system. They also indicate that the energy conversion process that takes place through a PV-electrolyzer-storage-FC chain is much more complex than a simple direct load supply. However, the PV/FC system is able to avoid energy surplus losses and can store more energy for longer periods of time [8].

Even though many efforts have been made towards simplifying the design of PV/FC systems, so far researchers have been unable to agree on a definitive optimum design process for such a system. There is a real need to explore optimum sizing of component selection, operational control strategies and performance-related issues in this area.

A feasibility study regarding the application of PV/FC systems in Iraq's remote areas has not yet been carried out. Therefore, this study on PV/FC systems is of particular importance when attempting to envisage the future energy supply needs of Iraq.

Considering the above facts, a PV/FC system for Al-Gowair village has been planned in order to obtain an optimal design, which includes the sizing of components, hourly-based operating states and the operational control strategy. Four main components of a PV/FC hybrid power system which will be examined, namely PV, the electrolyzer, hydrogen storage tanks, fuel cells as well as other accessories. The stored hydrogen and oxygen furnish the fuel cells in a controlled fashion without interruption when the PV system cannot supply sufficient power to the electrolyzer and accessories during off-solar days.

## 2. HOME R Software

The Hybrid Optimization Model for Electric Renewable (HOMER) is software that is used to perform comparative economic analysis on distributed generation power systems. The data inputted into the HOMER software will perform an hourly simulation for every possible combination of the components. These inputs are used to rank the systems according to user-specified criteria, such as cost of energy (COE) or capital costs. Furthermore, HOMER simulations can perform 'sensitivity analysis', in which the values of certain parameters, such as cost of fuel cells, are varied in order to determine their impact on the COE [9].

## 3. Load Profile

In the first step of the design process, load analysis is performed by considering the electrical loads over an average day. In real-life data, the load profile will vary from day to day due to the size and shape of the load consumption. In simulation, to achieve the real conditions, some noise inputs are added to the load data profile. In both cases, day-to-day and time-step-to-time-step, a small random variability of 3% has been applied. Variations due to seasonal affects are also considered as another factor of variation in the load.

The daily consumption of electrical energy in village during June to October is shown in Table 2. It was assumed that the load of each hour would be reduced by 2 kW during November to February, while the load would be reduced to 3 kW for each hour during March to May. The daily load demand in Al-Gowair village during June to October is shown in Figure 1 [10]. Figure 2 shows the monthly average load profiles [11].

Table 2. The daily consumption of electrical energy in Al-Gowair village

Time (Hour)	Load (kW)	Time (Hour)	Load (kW)
1	16.3	13	28.3
2	8.2	14	29.8
3	9.0	15	27.8
4	12.1	16	33.7
5	13.5	17	37.4
6	21.5	18	54.5
7	22.3	19	50.0
8	24.3	20	31.8
9	30.9	21	28.6
10	32.0	22	23.1
11	29.7	23	22.9
12	37.3	24	16.8
Total load			641.8kWh

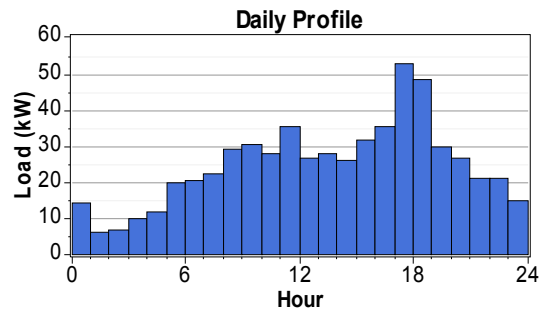

Figure 1. The daily load demand in Al-Gowair village during June to October [11]

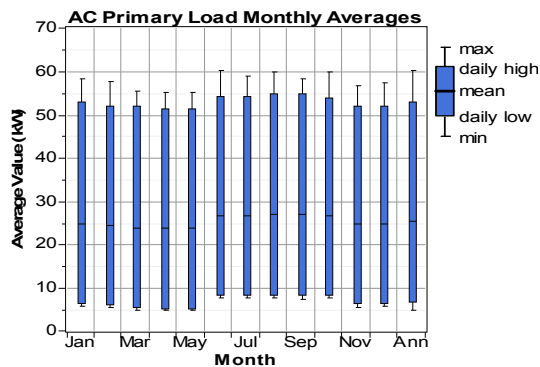

Figure 2. Monthly averages load profile

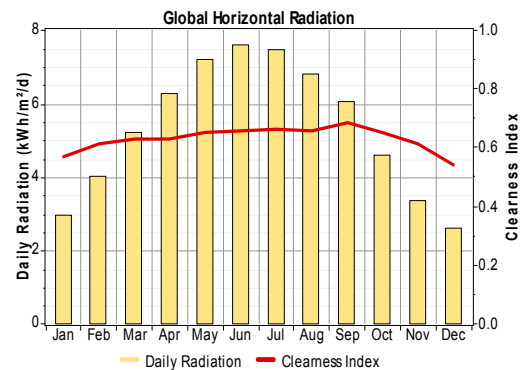

Figure 3. Monthly average daily radiation and clearness index

#### 4. Solar Radiation Resource

The daily sunshine profile as a monthly average over the course of a year is illustrated in Figure 3. It represents the monthly clearness index of Al-Gowair. All the data was gathered for latitude 34° 9' North and longitude 42° 26' East [12]. It should be noted that during the summer season, solar radiation attains its maximum level. The highest level is during June, with daily radiation levels reaching around 7.6 kWh/m<sup>2</sup>/d. Then, during the winter season it attains the minimum value, which takes place during December with daily radiation levels of around 2.6 kWh/m<sup>2</sup>/d. These levels are similar to the reliable solar radiation level in Iraq.

#### 5. System Description

A hybrid-type power generation system consists of a PV module equipped with a controller that is used to attain maximum power-point trackers, a pressurized storage tank for

H<sub>2</sub> storage, fuel cells, inverter (DC-AC) and electrolyzer for H<sub>2</sub> production as shown in Figure 4. The whole system has been designed using HOMER as shown in Figure 5. Furthermore, several component prices for this study are obtained from previously published papers [13, 14].

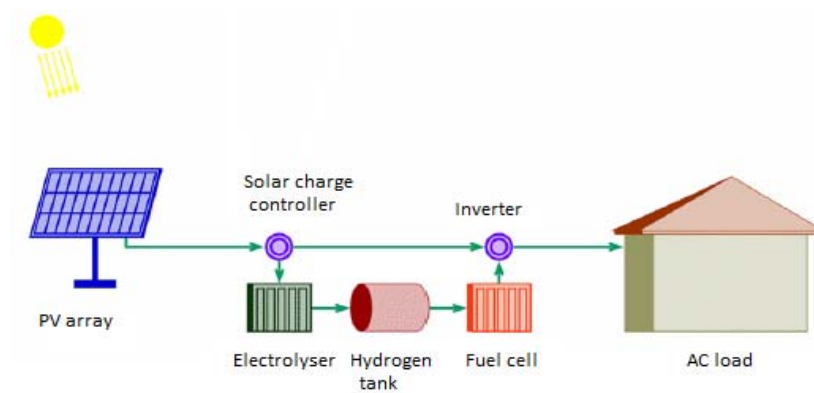

Figure 4. The configuration of a PV/FC hybrid power generation system

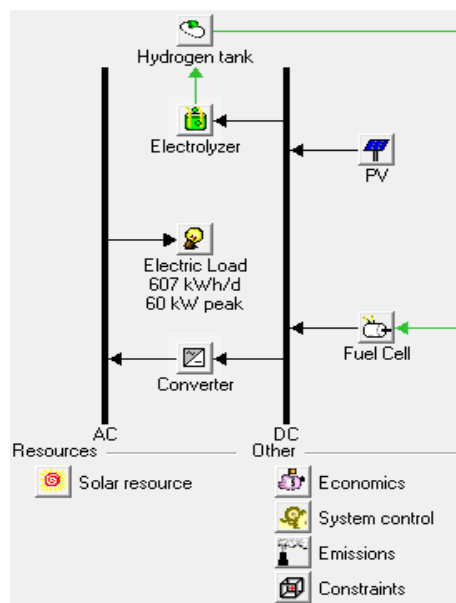

Figure 5. The configuration of a PV/FC hybrid power generation system in HOMER software

### 5.1. PV System

The PV system consists of arrays of solar cells, which are commercially available in many types of power and voltage ranges. For example, the simplest PV power module is found in many types of small calculators and wristwatches. Larger PV modules are utilised for electrical water pumps, communication towers, home appliances, etcetera [11, 15]. The utilization of PV systems for electricity generation provides substantial advantages over conventional power sources, for example: (1) PV is environmentally friendly—there are no harmful greenhouse gas emissions during the generation of electricity; (2) solar energy is obtained from natural resources, which are free and in abundance; (3) the current cost of PV is on a fast-reducing track and this reduction is expected to continue for the next several years, therefore, PV panels have a promising future in terms of economic viability; (4) PV panels convert sunlight into electricity in a direct way; and (5) PV panels have very low operation and maintenance costs [16].

In order to cater to the electrical demand in Al-Gowair, the capacity of the PV module has been determined as needing to be capable of producing between 0 kW to 280 kW. This information will be applied to the HOMER, along with the capital cost, replacement cost, O&M cost, lifetime and tracking system. The details of the input data for the PV module are provided in Table 3.

Table 3. PV input details

Size to consider (kW)	0-255-260-265-270-280
Capital cost (\$/kW)	5600
Replacement cost (\$/kW)	5600
O&M cost (\$/kW/yr)	0
Lifetime (year)	25
Tracking system	Two axis

**5.2. Fuel Cells**

A fuel cell combines hydrogen and oxygen to produce electricity. The basic principle of a fuel cell is illustrated in Figure 6. Hydrogen is fed to the fuel electrode (anode), where it is oxidized, producing hydrogen ions and electrons. In the meantime, oxygen is fed to the air electrode (cathode), where the hydrogen ions from the anode absorb electrons and react with the oxygen to produce water. The difference between the respective energy levels of the anode and the cathode is the voltage per unit cell. However, the current flows in the external circuit depend on the chemical activity and the amount of supplied hydrogen. The flow of the current will continue as long as there is a supply of reactants (hydrogen and oxygen) [17]. Detailed data of FC for the current study is provided in Table 4.

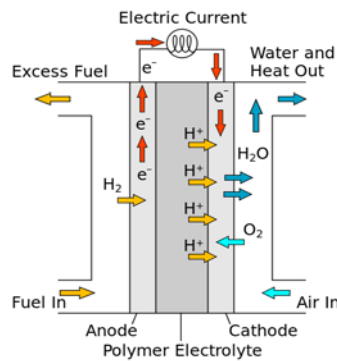

Figure 6. The basic principle of a fuel cell

Table 4. Fuel cells details.

Size to consider (Kg)	0-50-55-60-65
Capital cost (\$/Kg)	3000
Replacement cost (\$/kW)	2500
O&M cost (\$/kW/yr)	0.02
Lifetime (hour)	40000

Table 5. Specification of an inverter input details

Size to consider (kW)	0-55-60-65-70
Capital cost (\$/kW)	900
Replacement cost (\$/kW)	900
O&M cost (\$/kW/yr)	0
Lifetime (year)	15
Efficiency %	90

**5.3. Converter**

All PV and FC systems produce DC power, which cannot be directly applied to particular machines and home appliances. To convert the DC power to AC power, an inverter device is required. Since most electrical appliances have no built-in facility for accessing DC power, an inverter is of utmost necessity as part of the overall system. Inverter devices are available with different specifications of output wattage [18]. The inverter specifications detailed in **Error! Reference source not found.** are the values needed to cater the load profile.

#### 5.4. Electrolyzer

Electrolysis is the process in which an electric current is passed through water (H<sub>2</sub>O) in order to break the bonds between the hydrogen and the oxygen, yielding hydrogen (H<sub>2</sub>) and oxygen (O<sub>2</sub>) in separate states. In this project, the electrolysis process is used to get H<sub>2</sub> and store it in a hydrogen tank [19]. A stand-alone electrolyzer system, known as a Proton Exchange Membrane (PEM) electrolyzer, purchased from Proton Energy Inc., was used to obtain a cost estimate of a stand-alone (hydrogen by wire) electrolyzer. The details of the electrolyzer are provided in Table 6. All these components could be improved upon—for example, by replacing fittings with welded tube assemblies—in order to achieve further cost reductions [20]. In conventional systems, an electrolyzer produces hydrogen at low pressures (100-200 psi). The hydrogen is then compressed to elevate the pressure for gas storage. In recent decades, the resultant pressure is about 2500-3000 psi, which is expected to increase up to 6,000 psi in the very near future, through the application of improved techniques. As a result, it would eliminate the need for compressors. Given this context, it is assumed that a compressor will not be required for the current study [9].

#### 5.5. Hydrogen Tank

A tank for storing the hydrogen is a necessary element. The hydrogen storage specification is shown in Table 7, in which the variation of size is 0 kg to 140 kg. During the 25-year service period, this tank will need to be maintained annually. The cost of operation and maintenance of the hydrogen storage is \$15 per kg per annum. The stored hydrogen energy is used to overcome daily and seasonal discrepancies in order to meet the demand for reliably-sourced energy.

Table 6. Electrolyzer input details

Size to consider (kW)	0-230-235-240-245-250
Capital cost (\$/kW)	2000
Replacement cost (\$/kW)	1500
O&M cost (\$/kW/yr)	20
Lifetime (year)	15
Type	DC
Efficiency %	75

Table 7. Hydrogen storage details

Size to consider (Kg)	0-125-130-135-140
Capital cost (\$/Kg)	1300
Replacement cost (\$/Kg)	1200
O&M cost (\$/Kg/yr)	15
Lifetime (year)	25

### 6. Results and Discussion

The simulation was carried out based on a 25-year-long projection period and 6% annual real interest rate. The aim was to ensure the highest levels of reliability in terms of supply security, efficiency of the stand-alone PV/FC system and to properly define the operational strategy needed to maintain the generator, all of which can be summarized as follows:

(a) The first scenario was the PV system supplies the electricity immediately to the load demand. In this scenario the power of the PV system was equal to the load demand (P Load); (PV supply = P Load).

(b) The second scenario was if the power of the PV system exceeds the P Load. In such a situation, the PV system would immediately supply the P Load as well as distribute the excess power from the PV system to the electrolyzer in order to produce H<sub>2</sub>; (PV supply > P Load).

(c) Another scenario was that the PV system provides less electrical power than the P Load. In this scenario, the P Load would be supplied by both the PV system and the FC; (PV supply < P Load).

(d) Finally, if solar irradiation is unavailable, electricity might be supplied from the FC to the load demand; (PV supply = 0).

Furthermore, experiments were conducted in order to find the optimum values of each decision variable size, with the possible decision variables being (1) PV array, (2) fuel cell generator, (3) converter, (4) electrolyzer and (5) hydrogen storage tank. Figure 7. The overall optimization results showing system configuration sorted by the total net present cost presents the overall optimization results for the proposed system, including a list of different possible sizes for the components. The first row shows the optimum system configuration—meaning the one with the lowest net present cost.

**6.1. Equipment Optimization Analysis**

It was determined that 265 kW of PV output was the optimum size for the potential Al-Gowair PV/FC system. If lower sizes are used, they will result in an insufficient energy supply for the required loads, whilst higher sizes will significantly increase the capital cost. The monthly average PV output from January to December is illustrated in Figure 8. It should be noted that the maximum average output appears during the summer season, with the winter season having the lowest possible average output. A summary of the PV output results can be seen in Table 8. Summary of PV output results, which provides essential information regarding the quantity of PV output for Al-Gowair.

	PV (kW)	FC (kW)	Conv. (kW)	Elec. (kW)	H2 Tank (kg)	Initial Capital	Operating Cost (\$/yr)	Total NPC	COE (\$/kWh)	Ren. Frac.	Capacity Shortage	FC (hrs)
	265	60	65	230	135	\$ 2,358,000	36,209	\$ 2,820,874	1.004	1.00	0.01	5,072
	260	65	65	235	125	\$ 2,342,000	37,879	\$ 2,826,226	1.007	1.00	0.01	5,063
	265	60	70	230	135	\$ 2,362,500	36,329	\$ 2,826,902	1.006	1.00	0.01	5,072
	265	60	65	235	130	\$ 2,361,500	36,433	\$ 2,827,241	1.006	1.00	0.01	5,072
	270	60	60	230	125	\$ 2,368,500	35,898	\$ 2,827,393	1.005	1.00	0.01	5,064
	265	60	65	230	140	\$ 2,364,500	36,289	\$ 2,828,400	1.006	1.00	0.01	5,073
	260	65	70	235	125	\$ 2,346,500	37,999	\$ 2,832,254	1.009	1.00	0.01	5,063
	265	60	70	235	130	\$ 2,366,000	36,553	\$ 2,833,269	1.008	1.00	0.01	5,072
	270	60	65	230	125	\$ 2,373,000	36,022	\$ 2,833,488	1.008	1.00	0.01	5,065
	265	60	65	240	125	\$ 2,365,000	36,658	\$ 2,833,607	1.008	1.00	0.01	5,072
	265	60	70	230	140	\$ 2,369,000	36,409	\$ 2,834,428	1.008	1.00	0.01	5,073
	265	60	65	235	135	\$ 2,368,000	36,508	\$ 2,834,699	1.008	1.00	0.01	5,072
	270	60	60	230	130	\$ 2,375,000	35,973	\$ 2,834,852	1.008	1.00	0.01	5,064
	265	65	60	230	125	\$ 2,355,500	37,512	\$ 2,835,025	1.009	1.00	0.01	5,072
	265	60	60	235	140	\$ 2,370,000	36,469	\$ 2,836,197	1.008	1.00	0.01	5,073
	270	60	70	230	125	\$ 2,377,500	36,142	\$ 2,839,517	1.010	1.00	0.01	5,065
	265	60	70	240	125	\$ 2,369,500	36,777	\$ 2,839,635	1.010	1.00	0.01	5,072
	260	65	65	240	125	\$ 2,352,000	38,184	\$ 2,840,124	1.012	1.00	0.01	5,064
	265	60	70	235	135	\$ 2,372,500	36,628	\$ 2,840,728	1.010	1.00	0.01	5,072
	270	60	65	230	130	\$ 2,379,500	36,097	\$ 2,840,947	1.010	1.00	0.01	5,065
	265	65	65	230	125	\$ 2,360,000	37,631	\$ 2,841,053	1.011	1.00	0.01	5,072
	265	60	65	240	130	\$ 2,371,500	36,733	\$ 2,841,066	1.010	1.00	0.01	5,072
	270	60	60	235	125	\$ 2,378,500	36,202	\$ 2,841,285	1.010	1.00	0.01	5,065
	260	65	60	240	130	\$ 2,354,000	38,157	\$ 2,841,772	1.012	1.00	0.01	5,067
	265	60	65	235	140	\$ 2,374,500	36,589	\$ 2,842,225	1.010	1.00	0.01	5,073
	270	60	60	230	135	\$ 2,381,500	36,048	\$ 2,842,311	1.010	1.00	0.01	5,064
	265	65	60	230	130	\$ 2,362,000	37,587	\$ 2,842,483	1.012	1.00	0.01	5,072

Figure 7. The overall optimization results showing system configuration sorted by the total net present cost

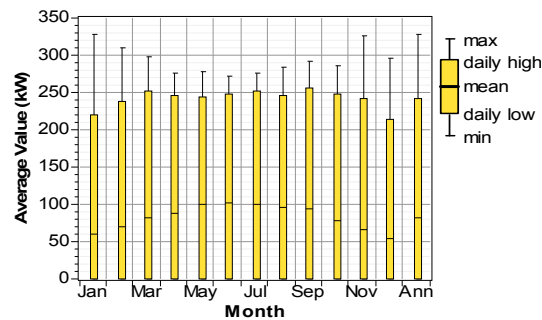

Figure 8. Monthly average output of PV

Quantity	Value	Units
Rated capacity	265	kW
Mean output	83	kW
Mean output	1,981	kWh/d
Capacity factor	31.1	%
Minimum output	0.00	kW
Maximum output	327	kW
Hours of operation	4,385	hr/yr
Total production	722,970	kWh/yr

In order to account for the required load, the optimum size of the FC should be 60 kW. This is enough to supply the necessary load even when the output of PV turns to zero during the night. The results of the FC output in the simulation have been summarized in Table 9. Summary of fuel cell output results. Meanwhile, Figure 9 contains the data in regard to the daily profile of FC output. As can be seen from the supplied data, the maximum FC output occurs mostly at 06:00 PM. However, the FC output ramps down during the sunlight hours and becomes zero if PV output attains a threshold point where it can handle the entire load. In terms of the monthly average output of FC, as shown in Figure 10, it can be seen that during the winter season, the FC output intensifies as the PV output goes down due to a reduction in solar radiation.

Table 9. Summary of fuel cell output results

Quantity	Value	Units
Hours of operation	5,072	hr/yr
Operational life	7.89	yr
Capacity factor	19.6	%
Electrical production	103,001	kWh/yr
Mean electrical output	20.3	Kw
Fuel energy input	206,002	kWh/yr
Mean electrical efficiency %	50.0	%

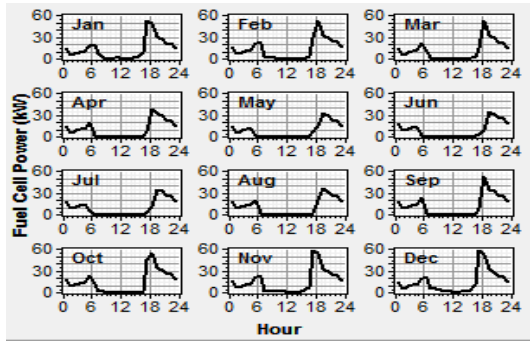

Figure 9. Daily profile of fuel cell out

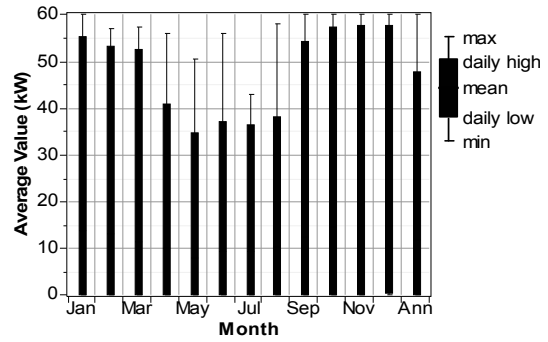

Figure 10. Monthly average output of fuel cell

FC represents an attractive option as an intermittent source of electricity generation because of its characteristics, such as high efficiency, fast load response, modularity and fuel flexibility. Unlike batteries, FC does not need to be recharged. In fact, FC will continuously produce electricity as long as fuel is supplied to the unit. This is in direct contrast to batteries, whose electrodes are permanently consumed during their operating time, which ultimately results in the batteries running out of energy [21]. According to Georgi, L.[22], some advantages of FC are its high electrical and total efficiency potential (much higher than the combustion engine), low emissions (zero emission), low maintenance and low noise.

For both small and large-scale systems, one efficient method of obtaining hydrogen is by using an electrolysis method, whereby PV can be coupled with an electrolyzer to produce hydrogen. This is the cleanest source of producing hydrogen without causing pollutant emissions. PV-based hydrogen production plants are flexible systems, in other words, it is easy to customise [9] such a system to meet a specific region's needs.

In order to design an effective PV/FC system, one important thing to be considered is the converter (inverter) efficiency factor. The inverter efficiency factor depends on constant power being supplied over a certain duration. Hence, a perfect PV/FC design involves properly determining the input/output wattage of the inverter. From the HOMER simulation, it was observed that 65 kW is the suitable capacity for the PV/FC system in this instance. Some details regarding the required quantity output for the inverter are given in Table 10. Meanwhile, in line with load profile, the daily profile of the inverter, as detailed in Figure 11 shows that the maximum output of the inverter occurs at 06:00 PM.

The electrolyser requires 230 kW in order to produce sufficient hydrogen for utilization of the FC. Information regarding the monthly average electricity consumption absorbed by the electrolyzer (electrolyzer input), as well as the output, is illustrated in Figure 12 and Figure 13 respectively. During sunlight hours-at which point PV produces an electrical power output-the shape of the curves of the electrolyzer output power, as shown

Figure 14, is similar to the curve of the PV output.



Table 10. Summary of inverter output results

Quantity	Inverter	Rectifier	Units
Hours of operation	65	0	hrs/yr
Mean output	25.1	0.00	kW
Minimum output	0	0.00	kW
Maximum output	60.1	0.00	kW
Capacity factor	38.6	0.0	%
Energy in	244,301	0	kWh/yr
Energy out	219,871	0	kWh/yr
Losses	24,430	0	kWh/yr

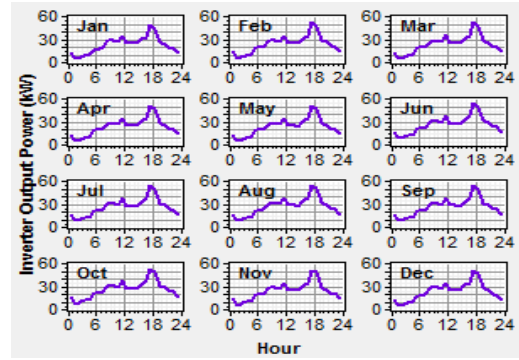

Figure 11. Daily profile of the inverter

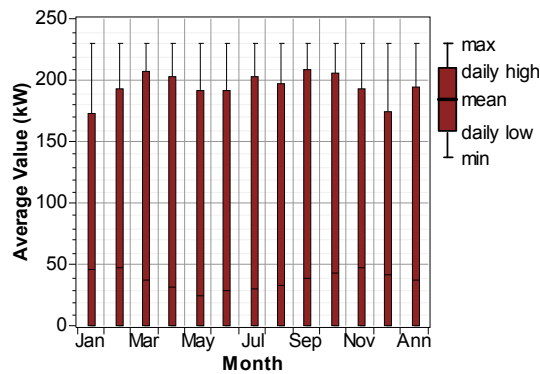

Figure 12. Monthly average electricity consumed by the electrolyzer

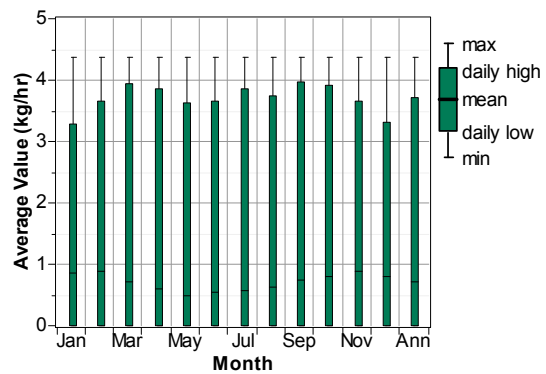

Figure 13. Monthly average output of the electrolyzer

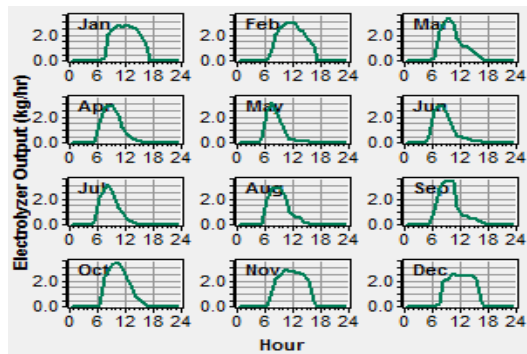

Figure 14. Daily profile of electrolyzer output

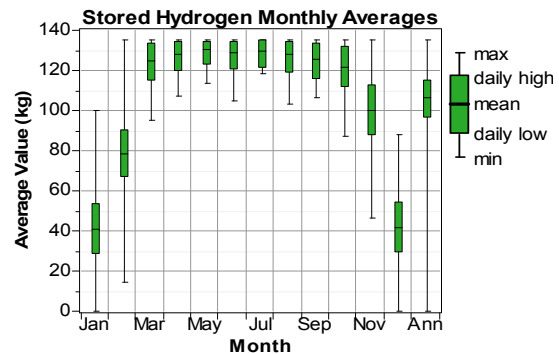

Figure 15. Monthly average stored hydrogen

A hydrogen tank with a capacity of 135 kg is required to store the hydrogen produced by the electrolyzer. A summary of results in accordance with hydrogen-tank production and consumption is shown in Table 11. Summary of the hydrogen tank results, reveals that every year there is a 2 kg surplus of hydrogen obtained. However, a detailed analysis regarding the impact of the hydrogen surplus for a 25-year service is still uncertain since no accurate information could be used as justification. Meanwhile, it should be noted that

Figure 15 shows that the monthly average amount of stored hydrogen is affected by the PV and electrolyzer outputs, in which the minimum values are during the months of minimum output of PV and FC and vice versa.

Table 11. Summary of the hydrogen tank results

Variable	Value	Units
Hydrogen production	6,182	kg/yr
Hydrogen consumption	6,180	kg/yr
Hydrogen tank autonomy	178	Hours

Even though lead acid batteries may be used for long-term energy storage, hydrogen storage has many advantages over batteries. For instance, batteries need constant monitoring and maintenance in order to ensure the power storage is in good condition, whilst hydrogen storage requires no such continuous care.

Recently, cost-effective pressurized tanks, which can be used safely for most applications, have become available for hydrogen storage. In cases of unfavourable weather conditions, a storage system is a very necessary part of a stand-alone energy system in order to ensure that energy can still be provided in emergencies, such as instantaneous overload conditions and solar off-day conditions [23].

**6.2. Cost to Build the System**

By using the HOMER simulation, it was determined that the estimated cost of the system is relatively expensive when compared with the average cost of an equivalent system that makes use of a diesel generator [14]. This is because the capital cost of PV and FC are more expensive than that of a diesel generator. However, taking advantage of new emerging techniques, the production cost should be significantly reduced in the future when taking into account an efficient and cost-effective design. In Figure 16, the cash-flow summary of the annual estimated costs is illustrated. Furthermore, net present cost (NPC) of the system for 25 years of service is shown in Figure 17. The cash-flow summary and NPC provide a similar profile, in which PV cost contributes the highest overall cost to the project. This is because the current price of PV modules is still fairly expensive. It should be noted that the cost of an electrolyzer is the second highest, followed by the FC, H<sub>2</sub> Tank and converter respectively. It is also essential to highlight that the lifetime of an electrolyzer is only 15 years, after which time it should be replaced with a new one. As a result, the replacement cost must be taken into account, which obviously affects the total cost of the electrolyzer portion of the system.

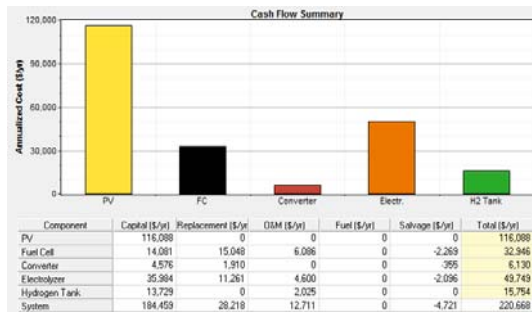

Figure 16. The cash-flow summary of the annualized costs

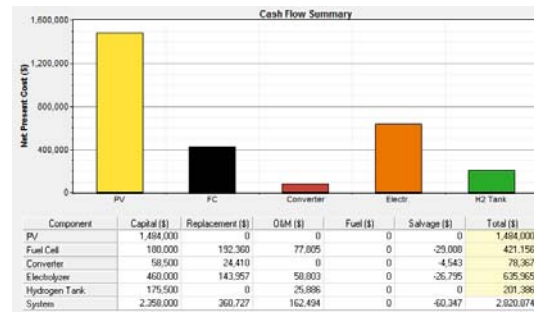

Figure 17. The cash-flow summary of the net present cost (25 years)

**6.3. Energy Production and Consumption Analysis**

Data regarding the energy production (as shown in Table 12), and energy consumption (as shown in Table 13), as well as the summary (as shown in Table 14), was obtained through the use of the HOMER simulation. From Table 12 and Table 13, it is obvious that PV is the main energy source being utilised to supply the entire primary load, including the electrolyzer. However, it is important to also consider that the electrolyzer absorbs 60% of the total energy produced by the PV – for 75% overall efficiency (see Table 6). For that reason, it will be essential to thoroughly study the electrolyzer efficiency being utilised by the real system prior to actual installation. Between the current two foremost types of electrolyzers, namely alkaline and

PEM electrolyzers, the PEM electrolyzer type requires less overall energy in order to function than an equivalent alkaline electrolyzer [24].

Table 12. Annual electric energy production

Component	Production	Fraction
	(kWh/yr)	%
PV array	722,970	88%
Fuel Cell	103,001	12%
Total	825,971	100%

Table 13. Annual electric energy consumption

Load	Consumption	Fraction
	(kWh/yr)	%
AC primary load	219,871	40%
Electrolyzer load	325,102	60%
Total	544,972	100%

Table 14. Summary of important electrical output results

Quantity	Value	Units
Excess electricity	256,568	kWh/yr
Unmet load	1,684	kWh/yr
Capacity shortage	2,405	kWh/yr
Renewable fraction	1,000	

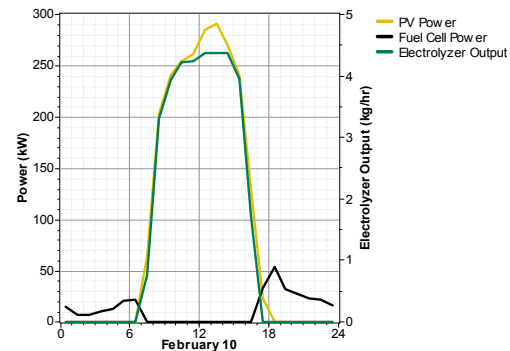

Figure 18. Contribution of electric energy production by various energy sources in an optimal system

Figure 18 presents collected data from the 10<sup>th</sup> of February, during which time the PV module begins to generate power from 06:30 AM and continues doing so until 06:30 PM. This energy is used to supply the load with the desired power output. However, during 06:30 AM to 07:30 AM and 04:30 PM to 06:30 PM, the supplied power is not enough to fully account for the requested energy load, so another generation device (FC) is added in to the loop in order to compensate for the lack of power during these periods. From 07:30 AM to 04:30 PM, the PV will be the only power supply needed in order to meet the load requirements, during which time the electrolyzer will also do its work. From 06:30 PM to 06:30 AM, the supply will depend solely on the FC. The subsequent daily output profile provides a comprehensive description about the PV/FC system. According to the results, the designed PV/FC system is feasible for implementation in order to cater to the energy demands of Al-Gowair.

## 7. Conclusion

A feasibility study regarding the use of PV/FC hybrid power systems for remote locations in Iraq has been carried out comprehensively by using the HOMER software. Based on the simulation results, the control strategies and the performance of the system components are acceptable for implementing in Al-Gowair. Though the NPC system is higher when compared to a diesel system for 25 years, the PV/FC, the PV/FC system operates completely independent from world fossil fuel price fluctuation (which is likely to only increase in the years to come). As an additional benefit, no harmful pollutants such as CO<sub>2</sub>, CO, NO<sub>x</sub> and SO<sub>2</sub> will be released into the environment. Considering varieties in load profiles and meteorological conditions, the proposed method could be safely implemented in similar cases for the optimization of hybrid PV/FC power systems.

## Acknowledgements

The authors would like to thank the Ministry of Higher Education and Universiti Teknologi Malaysia to conduct the research. Also the Dean, Faculty of Electrical Engineering,

Universiti Teknologi Malaysia is acknowledged for the permission to publish the results of the research.

### References

- [1] VA Ani, EO Ani. Assessment of Carbon Credits for Power Generation Systems at GSM Base Station Site. *International Journal of Renewable Energy Research (IJRER)*. 2013; 3: 763-768.
- [2] PS Solanki, VS Mallela, M Allan, C Zhou. Distributed Generation to Reduce Carbon Dioxide Emissions: A Case Study for Residential Sector in Oman. *Open Renewable Energy Journal*. 2010; 3.
- [3] G Léna. Rural Electrification with PV Hybrid Systems. Overview and Recommendations for Further Deployment. *IEA International Energy Agency*. 2013.
- [4] Wärtsilä. Energy Innovation as Key Driver for Responsibility: Liquid Biofuels and Gas. 2013.
- [5] M Hankins. Renewable Energy Plan for Mozambique, Justiça Ambiental, Maputo, Mozambique. 2013.
- [6] WJ Klunne. Small Hydropower in Southern Africa: An Overview of Five Countries in the Region. *Journal of Energy in Southern Africa*. 2013; 24: 14-25.
- [7] P Hollmuller, JM Joubert, B Lachal, K Yvon. Evaluation of a 5 kWp photovoltaic hydrogen production and storage installation for a residential home in Switzerland. *International Journal of Hydrogen Energy*. 2008; 25: 97-109.
- [8] G Zini, P Tartarini. Hybrid systems for solar hydrogen: A selection of case-studies. *Applied Thermal Engineering*. 2009; 29: 2585-2595.
- [9] H Abatcha, AM Jumba, L Maijama'a. Design and Simulation of a Hybrid PV/Fuel Cell Energy System. *Continental Journal of Engineering Sciences*. 2012; 6.
- [10] M AL-Kababjie, W Hamdon. Performance Evaluation study of Hybrid Generation System (Microhydro+ Diesel) in Iraqi Remote Rural Electrification. *Al-Rafadain Engineering Journal*. 2013; 21: 32-41.
- [11] S Karaki, R Chedid, R Ramadan. Probabilistic performance assessment of autonomous solar-wind energy conversion systems. *IEEE Transactions on Energy Conversion*, 1999; 14: 766-772.
- [12] Iraq Latitude and Longitude Map. 2013.
- [13] MZ Ibrahim, R Zailan, M Ismail, AM Muzathik. Pre-feasibility study of hybrid hydrogen based energy systems for coastal residential applications. *Energy Research Journal*. 2010; 1: 12.
- [14] KY Lau, M Yousof, S Arshad, M Anwari, A Yatim. Performance analysis of hybrid photovoltaic/diesel energy system under Malaysian conditions. *Energy*. 2010; 35: 3245-3255.
- [15] H Post, M Thomas. Photovoltaic systems for current and future applications. *Solar Energy*. 1988; 41: 465-473.
- [16] I Nawaz, ME Khan, M Rafat. Role of Solar Photovoltaic Technology (SPVT) in Meeting the Power Demand. *Journal of Environmental Science*. 2013; 2: 541-550.
- [17] B Frano. PEM Fuel Cells: Theory and Practice. New York: Elsevier Academic Press. 2005.
- [18] A Shiroudi, SRH Taklimi. Demonstration project of the solar hydrogen energy system located on Taleghan-Iran: Technical-economic assessments. *World Renewable Energy*. 2011; 4: 1158-1165.
- [19] H Abdel-Aal, K Zohdy, MA Kareem. Hydrogen Production Using Sea Water Electrolysis. *The Open Fuel Cells Journal*. 2010; 3: 1-7.
- [20] Ø Ulleberg. Stand-Alone Power Systems for the Future: Optimal Design, Operation & Control of Solar-Hydrogen Energy Systems," Doctor of Philosophy NTNU, Trondheim, Norvège, Norwegian University, Trondheim, 1998.
- [21] M Sedighzadeh, A Rezazadeh. *Comparison between Batteries and Fuel Cells for Photovoltaic System Backup*. Proceedings of World Academy of Science: Engineering & Technology. 2007; 36: 772-776.
- [22] L Giorgi, F Leccese. Fuel Cells: Technologies and Applications. *The Open Fuel Cells Journal*. 2013; 6: 1-20.
- [23] A Shiroudi SRH, Taklimi SA, Mousavifar, P Taghipour. Stand-Alone PV-Hydrogen Energy System in Taleghan-Iran Using HOMER Software: Optimization and Techno-Economic Analysis. *Environment, Development and Sustainability*. 2013; 15: 1389-1402.
- [24] DL Stojić, T Grozdić, B Umićević, A Maksić. A comparison of alkaline and proton exchange membrane electrolyzers. *Russian Journal of Physical Chemistry A, Focus on Chemistry*. 2008; 82: 1958-1960.