

Development of Air Quality Monitoring System in Closed Environment

Li Bochen*, Ding Xibo, Cai Qingyao

Higher Educational Key Laboratory for Measuring & Control Technology and Instrumentation of Heilongjiang Province, Harbin University of Science and Technology, China

*Corresponding author, e-mail: libochen007@163.com

Abstract

For closed environment, the characteristic is that the confined space is small and it doesn't flow with the outside world, it will produce nausea, dizziness, weakness and other symptoms if one stayed in that environment for long time. For this, developing a monitoring system of air quality in closed environment has theoretical significance and great value. In this paper, a modular design method is used to design a closed air quality monitoring system. The air quality monitoring system is composed of a main board and detection modules. When the measured closed environment is changed, it is only necessary to add or reduce the corresponding detection module, which increases the flexibility of the system and the convenience of later maintenance, and evaluation algorithm based on fuzzy mathematics is established. The measurement and air quality evaluation experiments are carried out using the developed monitoring system. The results show that the air quality evaluation algorithm can effectively evaluate the environmental air quality, and the measurement accuracy of the environmental parameters can meet the relevant standards.

Keywords: closed environment, air quality assessment, multi-parameter, modular

Copyright © 2017 Universitas Ahmad Dahlan. All rights reserved.

1. Introduction

Closed environment is not connected with the atmospheric environment, the internal can be seen as a closed environment of self-forming system, Mine rescue capsule, a special sealing workshop, submarine, deep water work boat, the spacecraft and so on are all such environment. Closed environment due to the narrow range of activities, personnel intensive, and machine waste gas, human metabolism and other waste generated by a long time cumulative pollution sealed environment, When the staff has been in such a small closed environment operation or activities, there may be some dizziness, tinnitus, night sweats, irritability, shortness of breath and other phenomena, there may be some dizziness, tinnitus, night sweats, irritability, shortness of breath and so on, which will greatly affect the lives of staff health and reduce operating efficiency [1,2]. In order to ensure the quality of life and work efficiency of the staff in the closed space, it is necessary and meaningful to provide a real-time measurement of the air quality in a closed environment and to evaluate the air quality of a closed environment with a scientific algorithm [3].

At present, some researchers have carried out more in-depth studies on the related gas (carbon monoxide, oxygen, hydrogen sulfide, etc.), temperature and humidity measurement theories, and the results are more abundant [4-7]. At the same time, some technology companies have developed a variety of gas detection devices, such as temperature and humidity meter, carbon monoxide alarm, carbon dioxide detector, oxygen detector and so on [8-10]. This kind of related instrument has superior performance, good reliability, but most of them can only detect one or several parameters, not capable of monitoring of air quality in closed environment, the reasonable evaluation quality given the closed environment is more difficult to complete. In both domestic and foreign countries, most of the closed environment parameters are measured in a single discrete manner, and few integrated systems are used to measure the closed environment parameters.

In this paper, a modular real-time closed air quality monitoring system is developed, the system can achieve high precision, high reliability and real time measurement of the main environmental parameters in the closed environment. Modular design allows users to increase

or reduce the specific detection module for specific pollutants in different environments, taking into account the needs of low cost and multiple functions, and to meet the different applications.

2. Composition and Working Principle of Monitoring System

The air quality monitoring system in closed environment is composed of a main board and a plurality of relatively independent detection modules. The overall block diagram of the system is shown in Figure 1. The basic measurement parameters of system are: Oxygen, carbon dioxide, differential pressure, ambient temperature and humidity, toxic gases (carbon monoxide, hydrogen sulfide) and other environmental parameters, Specific environment can be based on the situation to increase or decrease the detection parameters, such as ammonia, formaldehyde, etc [11]. Air quality monitoring can provide the basic parameters of the air quality to the field staff, and through the environmental air quality assessment algorithm gives a credible assessment of the air quality [12].

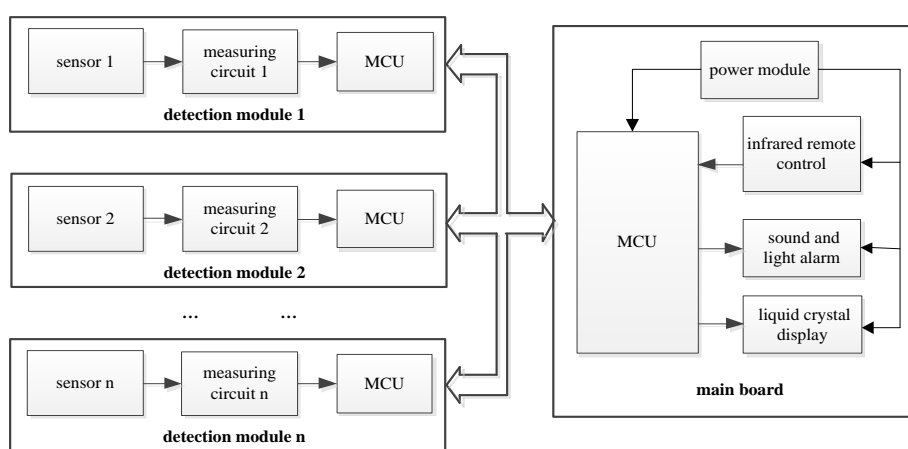

Figure 1. Overall Block Diagram of Monitoring System

The main board is used to receive data signals of detection module, determine whether the environmental parameters are overrun, evaluate the environmental quality and other work, the main board also sets monitoring parameters upper or lower limit, the main board also sets the upper limit or lower limit of monitoring parameters, module calibration, system parameter settings and so on. In the detection module, the gas sensor transforms detected gas data into a weak analog signals, after the measurement circuit filtering, amplification into MCU for A/D conversion, through the data processing program converts data into the value of the environment parameters, and then sent to the main board through the serial interface. The environmental parameters of different environmental monitoring systems are certain different, in order to meet the needs of many aspects, the detection module can be flexibly combined to adapt to monitoring requirements of different closed environment.

3. Design of Monitoring System

3.1 Design of the main board

The core design of the main board is the PIC16F882 MCU, including power circuit, display circuit, alarm circuit, infrared receiving circuit and so on. Figure 1 is the composition of the main board [13].

3.1.1 Design of main board MCU system

The main board MCU needs to communicate with the detection module microcontroller, and collects the current measured value of each module. The main board microcontroller compares each of the module data which is collected to respective alarm limit, and to determine whether the overrun. The main board MCU is also used in this paper air quality evaluation

algorithm for air quality evaluation. In addition, this microcontroller also has infrared remote control, sound and light alarm and liquid crystal display and other functions. The schematic diagram of this main board microcontroller system is shown in Figure 2.

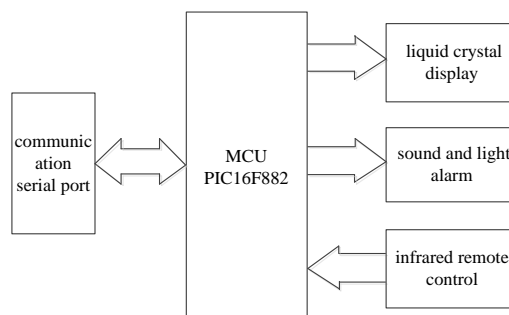

Figure 2. Schematic Diagram of Main Board MCU System

3.1.2 Design of power module

The power module of the system is on the main board, which is responsible for the power supply of the whole monitoring system, which can generate a variety of specifications voltage for the system. First, the industrial field 12V power supply voltage is converted to isolated 5V voltage by Mornsun isolated power supply WRB1205, the isolated 5V voltage is converted to 3.3V by the voltage stabilizing device AMS1117 and then supplies for MCU, the reference voltage required for analog circuits is provided by TL431.

3.1.3 Design of LCD screen display driver interface

The system uses 12864 LCD screen as the display of human-computer interaction interface. The LCD screen for the dot-matrix, with the Chinese font, provides more convenient using for single-chip design products. The LCD interface circuit is shown in Figure 3.

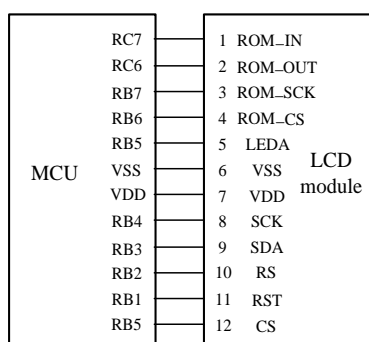

Figure 3. LCD Module Interface Principle Diagram

3.1.4 Design of infrared remote control receiver circuit

Infrared remote controller is used to set up the various settings and work control of the system, including environmental temperature and humidity display, output mode display, output mode control, calibration of each parameter and so on. The infrared remote control receiving circuit of the main board is shown in Figure 4, the integrated receiver head HS0038B is adopted to design, so no external devices are required. Using MCU external interrupt pins RB0 as the receiver of data pins with external interrupt mode to send data to the MCU.

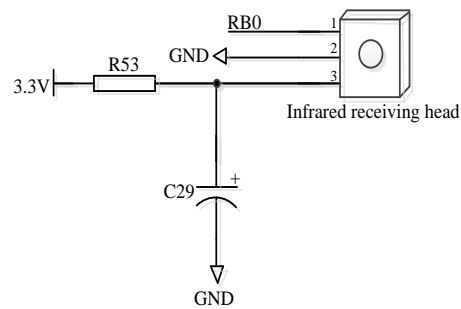

Figure 4. Infrared Remote Control Receiving Circuit

3.1.5 Design of sound and light alarm circuit

Sound and light alarm circuit is shown as Figure 5. When any environmental parameter exceeds a preset alarm value, the alarm circuit is started. Through MCU RC3 port sending a frequency of 0.5Hz of square wave, driving LED strobe and making the buzzer sound about 80db, to remind the staff attention.

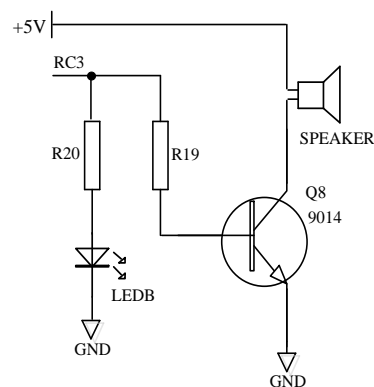

Figure 5. Sound and Light Alarm Circuit

3.2 Design of detection module

The detection module comprises a gas sensor, a measuring circuit and MCU, as shown in Figure 1. The measuring circuit can amplify the electrical signal of the gas sensor into the voltage signal suitable for MCU processing, and the A/D conversion, data processing and temperature compensation are carried out by MCU, and then sent to the main board through the asynchronous serial port. This paper adopts the modular design method to design the detection module, the detection module removing sensitive components and measuring circuit are different, the other part is completely the same, so the design of each module is basically the same. This paper only introduces the design of the carbon monoxide detection module, and the other modules are not introduced.

3.2.1 Selection of sensors

This paper uses CO-AF sensor of Alphasense to measure carbon monoxide, which belongs to the electrochemical gas sensor. The sensitivity of the sensor is 50nA/ppm, the range is 0-2000ppm, using three pin package. The work process is: carbon monoxide gas through the filter membrane taking the oxidation reaction with working electrode, produces a current signal proportional to the concentration of the gas [14].

3.2.2 Design of measuring circuit

Carbon monoxide measurement circuit principle diagram is as shown in Figure 6. When the concentration of carbon monoxide changes 1ppm, the change of the pin current of the working electrode WE is less than 90nA, so it has a higher requirement for the amplifier for processing that signal. This paper uses CMOS type with ultra low bias current of the transimpedance amplifier ADA4505-2, the typical input bias current of 0.5pA, offset voltage drift 2.5 μV/°C, input and output rail to rail completely, so the op amp fully meet the weak signal amplification requirements.

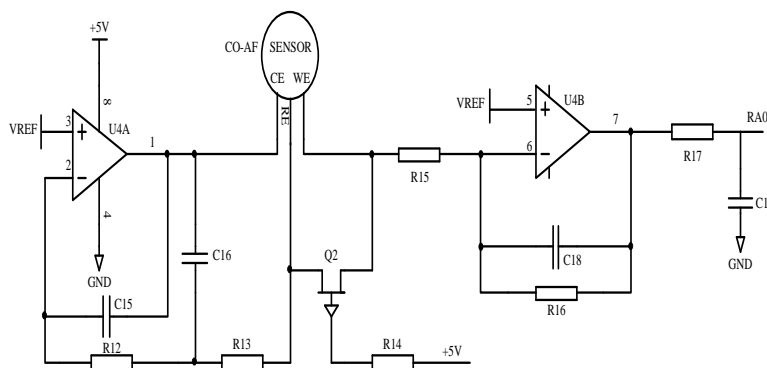

Figure 6. Principle Diagram of Carbon Monoxide Measurement Circuit

3.2.3 Design of MCU circuit of detection module

MCU detection module is as the control center, it needs for the amplified analog signal for data acquisition, processing, etc. after the completion of the calculation will be measured value and the main board using the serial communication to achieve information transmission. Circuit schematic diagram is shown in Figure 7.

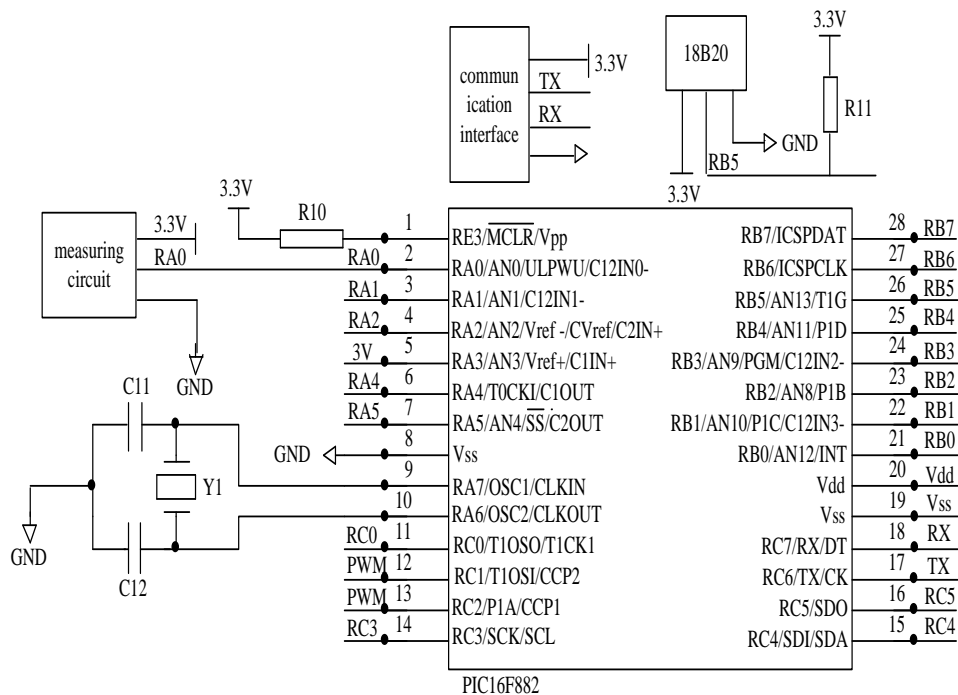

Figure 7. Circuit Schematic of Detection Module MCU

4. Fuzzy Evaluation Model of Air Quality

At present, the theoretical research on the evaluation of air quality is not perfect, The usual practice is to set the upper and lower bounds on the related parameters, an alarm is issued after the limit is exceeded and the limited range is graded [15]. Due to the complexity of the closed environment, the time continuity of the related parameters, sometimes the comfort of the whole closed environment can be changed by only one indicator [16]. To this end, this paper studies the use of fuzzy mathematics theory to evaluate air quality in closed environment. The structure diagram of air quality evaluation in closed environment based on fuzzy mathematics is illustrated in Figure 8 [17]-[18].

In Figure 8, s_n is the influencing factor, that is, the determining factors of air quality in closed environment, α_n is the weight factor, which is the weight of the corresponding influence factor, P is the weight set, R is the correlation matrix, Q is the air quality assessment criteria in closed environment.

The evaluation algorithm of air quality in closed environment is as follows: First of all, to determine the relevant impact factors, accurate positioning of the impact factor can accurately give the air quality assessment of the closed environment, The influence factors designed in this paper can refer to Table 2 key technical indicators; secondly, due to different influence factors have different influence on the impact of the closed environment, it is required to give the weight of different factors α_m , weight can be used to measure the influence of the related factors on the air quality in closed environment; again, according to the characteristics of different factors, the corresponding correlation function is given, the function uses the mathematical point of view to quantitatively reflect the relationship between the influence factor and the closed environment; finally, comprehensive evaluation criteria, using the fuzzy transformation to calculate the correlation degree, and then the model is used to evaluate the air quality in closed environment.

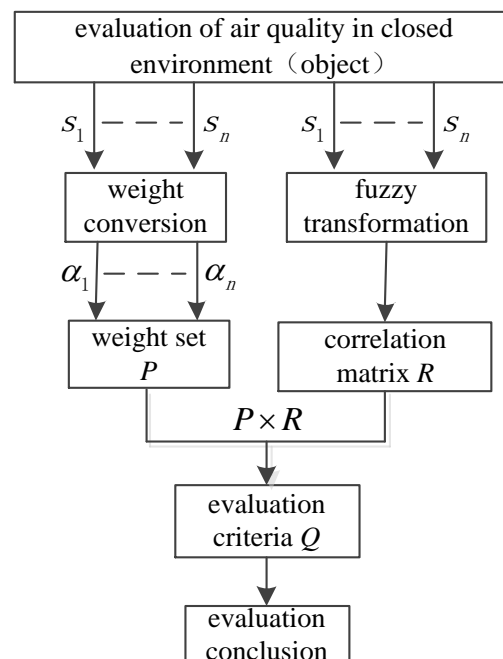

Figure 8. Block Diagram of Air Quality Assessment in Closed Environment

The relevant mathematical model is as follows: It is assumed that there are n factors affecting the air quality in closed environment, then it will form the corresponding influence factor set $S = \{s_1, s_2, \dots, s_n\}$, the corresponding weight set $P = \{\alpha_1, \alpha_2, \dots, \alpha_n\}$, In order to facilitate the

understanding of air quality in closed environment, this paper divides it into 5 grades: excellent, good, medium, poor and range, Assume that there are m levels, Then the evaluation set $Y = \{y_1, y_2, \dots, y_m\}$. By the impact factor set $S = \{s_1, s_2, \dots, s_n\}$, according to the correlation function, a fuzzy mapping from S to Y can be constructed, and then can get the correlation degree matrix R .

$$R = \begin{Bmatrix} Y_{11} Y_{12} \cdots Y_{1m} \\ Y_{21} Y_{22} \cdots Y_{2m} \\ \cdots \\ Y_{n1} Y_{n2} \cdots Y_{nm} \end{Bmatrix} \quad (1)$$

According to the R to Y fuzzy mapping can be found: $Q = PR$, Q for the $1 \times m$ order matrix, which is based on this algorithm to get the Air quality grade. Each element of the matrix represents the specific gravity of the corresponding level, taking the level of larger element value as the final level of closed environment. The establishment of correlation function is as follows:

$$\text{excellent: } y_{i1} = \begin{cases} 1 & u_i \leq e_1 \\ \frac{e_2 - u_i}{e_2 - e_1} & e_1 < u_i < e_2 \\ 0 & u_i \geq e_2 \end{cases} \quad (2)$$

$$\text{good: } y_{i2} = \begin{cases} 0 & u_i \leq e_1 \\ \frac{u_i - e_1}{e_2 - e_1} & e_1 < u_i < e_2 \\ \frac{e_3 - u_i}{e_3 - e_2} & e_2 \leq u_i < e_3 \\ 0 & u_i \geq e_3 \end{cases} \quad (3)$$

$$\text{medium: } y_{i3} = \begin{cases} 0 & u_i \leq e_2 \\ \frac{u_i - e_2}{e_3 - e_2} & e_2 < u_i < e_3 \\ \frac{e_4 - u_i}{e_4 - e_3} & e_3 \leq u_i < e_4 \\ 0 & u_i \geq e_4 \end{cases} \quad (4)$$

$$\text{poor: } y_{i4} = \begin{cases} 0 & u_i \leq e_3 \\ \frac{u_i - e_3}{e_4 - e_3} & e_3 < u_i < e_4 \\ \frac{e_5 - u_i}{e_5 - e_4} & e_4 \leq u_i < e_5 \\ 0 & u_i \geq e_5 \end{cases} \quad (5)$$

$$\text{range: } y_{i5} = \begin{cases} 0 & u_i \leq e_4 \\ \frac{u_i - e_4}{e_5 - e_4} & e_4 < u_i < e_5 \\ 1 & u_i \geq e_5 \end{cases} \quad (6)$$

In the formula, i is the related element of the influence factor, and e_i is the standard value of the i factor, and u_i is the actual measurement value of the influence factor of the i . The corresponding function curve is shown in Figure 9.

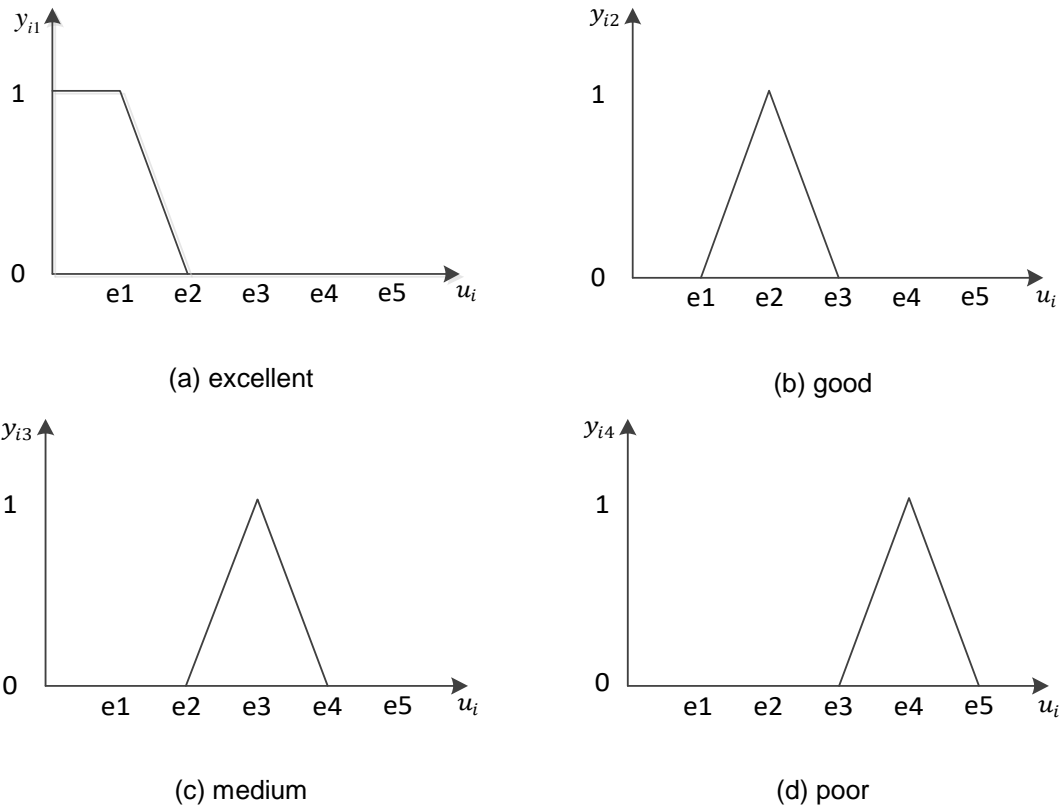

Figure 9. Correlation Function Curves

The measured data are brought into the corresponding correlation function, and then we can find the correlation degree y_{ij} which is related to the corresponding level of each influence factor, so the correlation degree set is $R_i = \{y_{i1}, y_{i2}, y_{i3}, y_{i4}, y_{i5}\}$, which can calculate the correlation matrix.

In this paper, the contribution rate is used to calculate the influence degree on air quality by impact factor, and the formula (7) is used to assign the weight, n is the number of the corresponding impact factors in formula.

$$P = \frac{u_i / e_i}{\sum_{i=1}^n u_i / e_i} \quad (7)$$

5. System Test Experiment and Result Analysis

Indoor air quality classification is the basis for the evaluation of indoor air quality. China has not yet introduced the standards for indoor air quality, in this paper, according to the actual application needs to develop a closed air quality classification table, as shown in Table 1. Environmental parameters of a closed environment measured values are as shown in Table 2.

Table 1. Classification of Closed Environmental Air Quality

Influence factor	Level				
	Y_1 excellent	Y_2 good	Y_3 medium	Y_4 poor	Y_5 range
CO ₂ (mg/m ³)	0.1	0.38	0.51	0.79	0.91
H ₂ S (mg/m ³)	0.1	0.2	0.3	0.4	0.5
CO (mg/m ³)	0.01	0.03	0.1	0.21	0.54
RH(%)	30	40	50	60	70

Table 2. Monitoring Value of Part of Closed Environment Parameter

Name	Influence factor			
	CO ₂ (mg/m ³)	H ₂ S (mg/m ³)	CO (mg/m ³)	RH (%)
Monitoring value	0.12	0.35	0.41	54

According to Table 1, the correlation matrix of the partial parameters of the closed environment is:

$$R = \begin{pmatrix} 0.93 & 0.07 & 0 & 0 & 0 \\ 0 & 0 & 0.5 & 0.5 & 0 \\ 0 & 0 & 0 & 0.39 & 0.61 \\ 0 & 0 & 0.6 & 0.4 & 0 \end{pmatrix}$$

According to the formula (7), we can calculate the impact factor weight set of Table 2.: $P=(0.02, 0.1, 0.8, 0.08)$. Therefore, the comprehensive evaluation results by Table 2 are:

$$Q = P \bullet R = (0.02, 0.1, 0.8, 0.08) \begin{pmatrix} 0.93 & 0.07 & 0 & 0 & 0 \\ 0 & 0 & 0.5 & 0.5 & 0 \\ 0 & 0 & 0 & 0.39 & 0.61 \\ 0 & 0 & 0.6 & 0.4 & 0 \end{pmatrix}$$

$$= (0.0186, 0.0014, 0.098, 0.394, 0.488)$$

According to the above results, the air quality level of the closed environment shown in Table 2 is Y_5 (the range).

6. Conclusion

In this paper, a closed environment air quality monitoring system is developed, compared to existing methods of detecting technology, the authors found that the international measurement for closed environment parameters are single discrete, few integrated modular methods are used to measure closed environmental parameters. The system mentioned in this paper uses the modular method to design, which can be used for real-time and accurate measurement of a variety of parameters in closed environment, at the same time, a specific

measurement module can be added to the specific pollutants in different environments, which not only saves the cost, but also realizes the measurement in all aspects. And an evaluation mathematical model based on fuzzy mathematics theory is established, and an algorithm to realize the model is given. The experimental results show that the system and its evaluation algorithm can give a appropriate evaluation of the air quality in closed environment.

References

- [1] Sun Jiping. Technologies of monitoring and communication in the coal mine. *Journal of China Coal Society*. 2010; 35(11): 1-4.
- [2] Fang Xikun. Discussion on indoor air quality monitoring. *Resources Economization & Environmental Protection*. 2013; 8: 166-166.
- [3] ZHAO Hanhong. Analysis of indoor air quality standard detection method. *Chemical Enterprise Management*. 2013; 12: 190-190.
- [4] FAN Aobo, TIE Zhixin, WU Mingcheng, et al. Design of indoor air quality monitoring system. *Journal of Zhejiang Sci-Tech University*. 2015; 33(5): 382-389.
- [5] YANG Shanli. The fabrication of novel electrochemical sensors and their applications in environmental detection. Hunan: Hunan University. 2014.
- [6] SHI Hongjun. Research and development of electrolyte of current type electrochemical gas sensor. *Technology Innovation and Application*. 2013; 5: 22.
- [7] JIA Qiang. Research and design of gas sensor based electronic circuits. *Tianjin Science & Technology*. 2015; (1): 36-38.
- [8] GE Zhongqin, QI Haifeng, ZHANG Heng, et al. Monitoring system for CO based on CAN bus. *Electronic Measurement Technology*. 2013; 36(7): 102-106.
- [9] ZHANG Haiqing. Design of mine infrared carbon dioxide sensor. *Colliery Mechanical & Electrical Technology*. 2015(6): 5-7.
- [10] CHEN Lunqiong. Oxygen density measuring apparatus in transformer substation. *Manufacturing Automation*. 2012; 34(12): 61-62.
- [11] DING Xibo, WANG Ruyue. Development of ammonia gas leak detection and location method. *Telkomnika*. 2017; 15(3): 1207-1214.
- [12] FAN Aobo, TIE Zhixin, WU Mingcheng, et al. Design of indoor air quality monitoring system. *Journal of Zhejiang Sci-Tech University*. 2015; 33(5): 382-389.
- [13] Wang Shoubin, Li Chengwei, Gong Wei, et al. Design of wind turbine vibration monitoring system. *Indonesian journal of electrical engineering and informatics*. 2013; 1(2): 64-68.
- [14] Cheng Hui, Yang Keli. Design of carbon-monoxide gas sensor for coal and mine exploitation. *Journal of Henan Textile College*. 2014; (1): 58-61.
- [15] Zhang Jing, Peng Fang, Wang Jiaqing. Realization and optimization of environmental air quality monitoring. *Mechanical & Electrical Engineering Technology*. 2014; 43(6): 62-65.
- [16] Yan Haixia. Development of the indoor air quality monitor. Harbin: Harbin Institute of Technology. 2014.
- [17] Zhou Xiaohong. Design of mine-used portable multi-parameter gas detector based on ARM. *Electronic Measurement*. 2014; 43(9): 75-78.
- [18] Tao Debao, Zhu Feng, Jiang Tao, et al. Design of mine-used portable multi-parameter gas detector. *Industry and Mine Automation*. 2014; 40(2): 92-95.