

Design of Miniaturized Multiband Patch Antenna Using CSRR for WLAN/WiMAX Applications

Murtala Aminu-Baba^{*1}, Mohammad Kamal A Rahim², Farid Zubir³,
Mohd Fairus Mohd Yusoff⁴

Department of Communication Engineering, Faculty of Engineering,
Universiti Teknologi Malaysia, (UTM), 81300 Skudai, Johor Bahru, Malaysia

*Corresponding author, e-mail: limaminkobi@yahoo.com¹, mkamal@fke.utm.my², faridzubir@utm.my³,
fairus@fke.utm.my⁴

Abstract

A novel miniaturized multiband, single-feed microstrip patch antenna is presented in this paper for WLAN and WiMAX applications. Both size reduction and multiband are obtained by etching the Multiple Complementary Split Ring Resonators (MC-SRR) on the ground plane of the normal patch antenna. At first, the normal patch antenna produces a single band of 5.15 GHz; 200 MHz (5.0500~5.2499). Subsequently, a Single Circular Split Ring Resonator (SC-SRR) is etched on the ground plane and produces a triple band of: 3.25 GHz; 288 MHz (3.1085~3.3964), 4.5 GHz; 101.3 MHz (4.4488~4.5501), and 5.22 GHz; 220 MHz (5.1191~5.3400) and Double Single Circular Split Ring Resonator (DC-MCSRR) with: 2.99 GHz; 60.7 MHz (2.9574~3.0181), 3.57 GHz; 324.7 MHz (3.4065~3.7312), and 5.1413 GHz; 115.4 MHz (5.0817~5.1971). The working bandwidths cover the desired frequency bands of WLAN 5.2 GHz and WiMAX 3.3/3.5 GHz. The proposed (MC-SRR) antenna can be employed to wireless communication systems due to its simplicity in design, compactness and miniaturization.

Keywords: Multiple circular split ring resonator (MC-SRR), Single circular split ring resonator (SC-SRR), Double circular split ring resonator DC-MCSRR, WLAN, WiMAX

Copyright © 2018 Universitas Ahmad Dahlan. All rights reserved.

1. Introduction

The recent proliferation of wireless communication systems has increased the use of the modernized wireless devices in the last decades. The size of these devices is continuously reduced for portability and cost reduction. Antenna element for transmitting and receiving signals, form the fundamental component for wireless communication devices. Over the years, microstrip antenna due its low costs, simplicity in design and fabrication, light weight and compact size has been the right choice to be used in various applications for wireless communication devices [1]. However, at lower frequency, the antenna size in addition to ordinary $\lambda/2$ patch antennas is quite big. To meet the requirement of the smaller communication devices to suitable patch antennas, antenna size reduction is required. Various size reduction techniques have been presented and reported, for example using high permittivity or dielectric substrate [2-4] and shorting pins [5, 6]. The design in [6] is another method of achieving in miniaturized antenna by employing grounded strips, which generate the capacitive and inductive loadings. However, for limited space environment, the antenna is large to occupy miniaturized modern devices. In [7], U-shaped & inverted U-shaped metamaterial structures were used to obtained dual band with quite size reduction for both the materials. The design presented a good miniaturization technique, but too complex to be used in a low-cost antenna design.

Meanwhile, some common communications systems such as WLAN and WiMAX operate in multiple frequencies. It is quite impossible to design antenna for each band in a confined and limited space environment. To overcome this challenge, a single antenna is to be designed to accommodate multiple fequency bands [8]. Various number of multiband antennas have been presented using different methodologies [9]. The antenna in [10] is based on the unidirectional patch antenna, with coupled-resonator-based circuit covering four bands (S & C). However, tuning the coupling between the resonators presents another complex technique in multiband design. In [4, 11-13], split-ring resonators were employed to achieve multiband

frequencies. The design in [12] has a simple SRR, but only two bands with narrow bandwidth were presented.

The methods proposed in the literatures above presented different techniques to achieve antenna miniaturization and multiband. In our design, a single method is proposed that provides a simple design for antenna miniaturization and multiband operation. By employing (MC-SRR) on the ground, multiple bands are achieved with miniaturization as well. The simulation results shows a good impedance matching, high gain and wide bandwidth at each frequency. The multiband frequencies covers the required bands for WLAN and WiMAX applications.

2. Antenna Design and Simulation Research Method

2.1. Split Ring Resonators (SRRs) and Complementary Split Ring Resonators (CSRRs)

Among the different types of Left Handed Metamaterial (LHM), Split Ring Resonators (SRR) is another metamaterial structure that is excited by axial magnetic field and produce negative permeability ($-\mu$). The capacitance between the rings balances the inductance since it is a highly conductive structure [14]. Figure 1 shows the two common topologies of SRR Structures and their equivalent circuit model.



Figure 1. Topologies of (a) Circular SRR (b) Square SRR (c) Their equivalent-circuit model [15]

Thus, a new element is introduced by etching the negative image of SRRs in the ground plane or the radiating element and this is known as the Complementary Split Ring Resonator (CSRR) as shown in Figure 2. To obtain the circuit model of both SRR & CSRR, Figures 1 and 2 are considered. From the Figure 1(c) of the circuit equivalent, the inductance L_s of the SRR is replaced by the capacitance C_c in Figure 2(c) which is surrounded by the ground plane. On the other hand, the two capacitance in Figure 1(c) that are connected serially are replaced by the two inductances in Figure 2(c), which are connected in parallel. These inductances connect the inner disk to the ground. The application of the parameters (Inductance and Capacitance) in the equivalent circuit model helps in creating another resonance frequency for multiband and miniaturization.

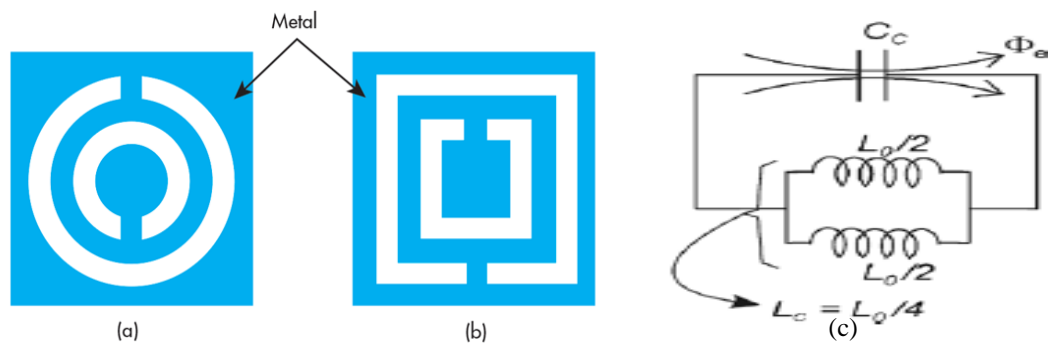

Figure 2. Topologies of (a) Circular CSRR (b) Square CSRR (c) their equivalent-circuit model [15]

2.2. Microstrip Antenna

The proposed single feed rectangular microstrip patch antenna is shown in Figure 3 (a) with its reflection coefficient (S_{11}) in Figure 4 together with the S_{11} of SC-MSRR. The conventional patch antenna has a bandwidth of 200 MHz (5.0500 ~ 5.2499) at 3.81% bandwidth. The dimensions of the antenna are shown in Table 1. FR4 substrate was used with permittivity of 4.3 and thickness of 1.6 mm. The simulated results show that the antenna has a good impedance matching and suitable for communications devices that require compact, lightweight, simple and miniaturized antennas.

2.3. Microstrip Antenna with SC-CSRR

The antenna element is a rectangular radiating patch antenna which is printed on a dielectric substrate with relative permittivity ϵ_r of 4.3 and thickness h of 1.6 mm. dimension of the conventional antenna and SC-CSRR is $45 \times 45 \times 1.6 \text{ mm}^3$ as shown in Figure 3 and 4. A microstrip line is used as a feeding source to integrate substrate and patch antenna. The designs and simulations were all carried out using CST Microwave Studio Software.

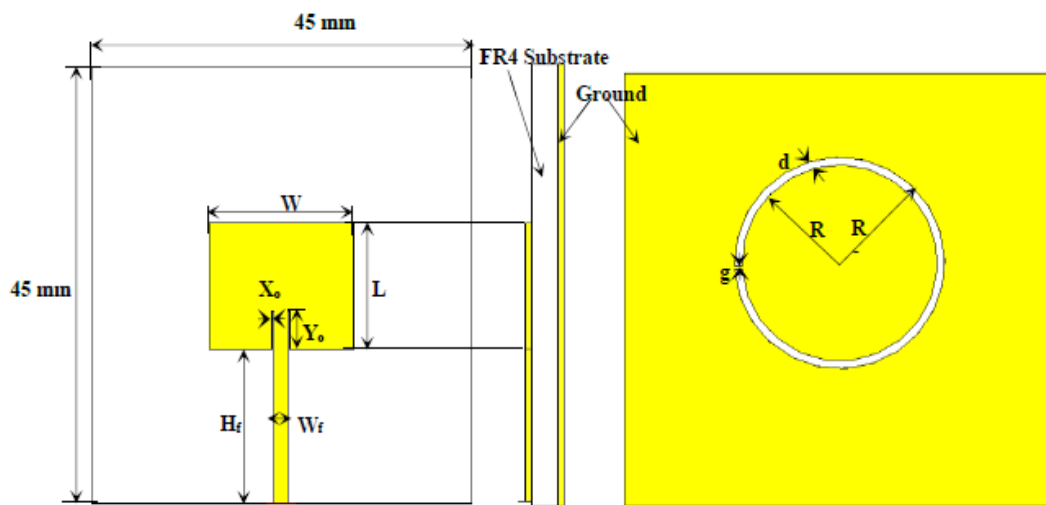

Figure 3. Antenna configuration (a) Top view (b) Side view (c) Bottom view

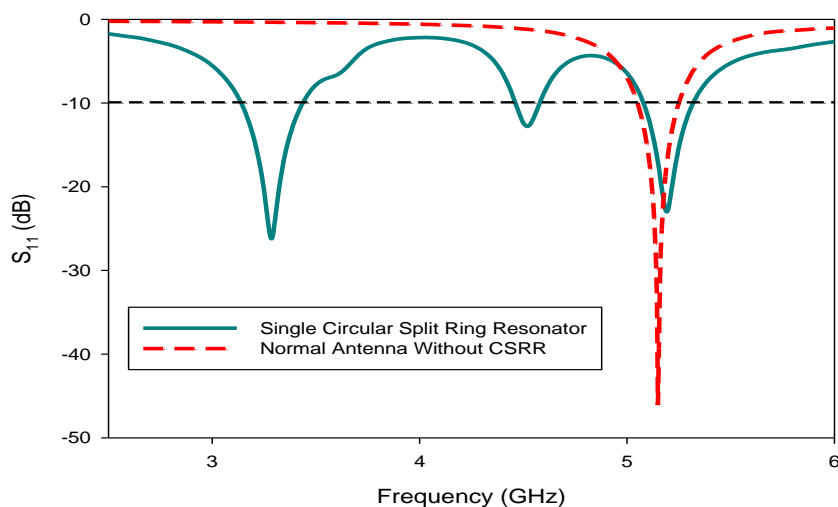

Figure 4. S_{11} of the conventional antenna and SC-CSRR antenna

Table 1. Antenna Dimensions

| Parameter | Dimension (mm) | Parameter | Dimension (mm) |
|----------------|----------------|----------------|----------------|
| W | 17 | d | 0.3 |
| L | 13 | g | 0.4 |
| X _o | 0.3 | R | 6.5 |
| Y _o | 4 | R _o | 6.8 |
| H _f | 16 | W _f | 1.6 |

At first, a SC-CSRR is etched on the ground plane of the patch antenna. The inclusion of SC-CSRR affects the first resonant frequency by introducing another two frequencies (3.25 and 4.5) GHz and 5.15 GHz in addition to the first band, which are used for WLAN and WiMAX applications. Figure 4 shows the reflection coefficient S_{11} of the SC-CSRR antenna. The addition of extra bands by the split ring SC-SRR is due the presence of the inductance and capacitance, which are the primary parameters in the resonance frequency created by the split ring.

2.4. Microstrip Antenna with DC-CSRR

By adding another ring to the first one in Figure 5, the frequency bands shift to the lower frequencies, thereby maintaining the bands in Figure 4 but slightly shifted to the left side. Thus, with the insertion of the double rings, the frequencies produced are 2.99, 3.57 and 5.14 GHz. Antenna miniaturization and multiband are both achieved by the influence of DC-CSRR. Thus, the application of DC-CSRR is not limited to miniaturization or multiband as presented from the previous literature but to both in our design. Parametric studies were carried out on each parameter in order to find the influence of them on S_{11} , bandwidth and resonant frequencies and various results were obtained. However, some parameter dimensions expressed a negative/low gain and narrow bandwidth. The above parameters are selected based on the good performance of $S_{11} < -10$, higher gain and good impedance matching.

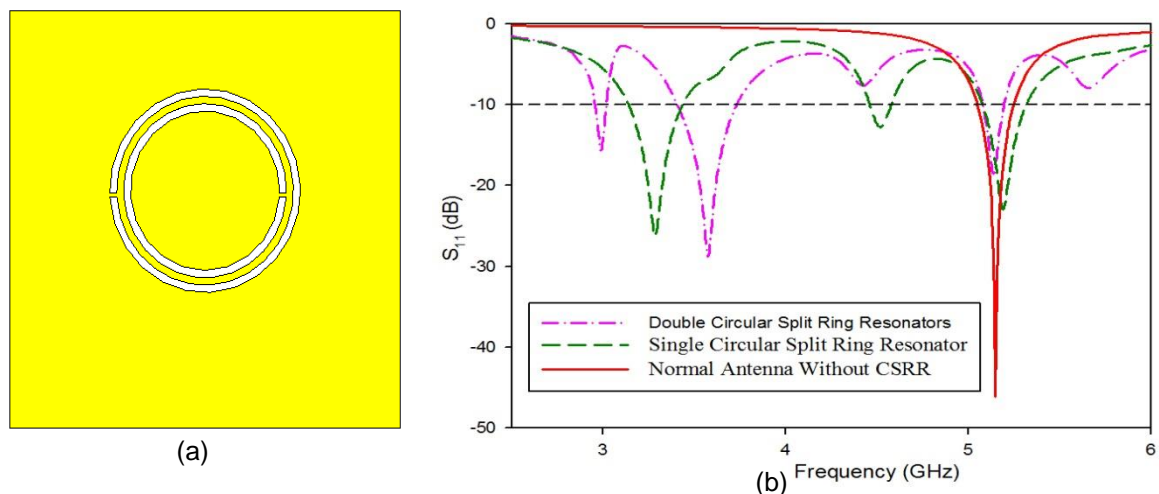

Figure 5. (a) DC-CSRR Metamaterial structure on the ground plane (b) S_{11} of the DC-CSRR Antenna

3. Results and Analysis

Table 1 shows the dimensions of the proposed antennas and has been designed and simulated based on the specifications given as shown in figure 3-5. Figures 6-12 show the radiation patterns in both e-field and h-field and the realized gain for each frequency.

The operating frequency obtained as well as the bandwidth of each antenna is presented in table 2. Details of the working bandwidths of each antenna is also discussed. Microstrip antenna without MCSRR 5.15GHz; 200 MHz (5.0500~5.2499), Microstrip with SC-CSRR 3.25GHz; 288 MHz (3.1085~3.3964), 4.5GHz; 101.3 MHz (4.4488~4.5501), and 5.22GHz; 221 MHz (5.1191~5.3400) and antenna with DC-CSRR 2.99GHz; 60.7 MHz

(2.9574~3.0181), 3.57GHz; 324.7 MHz (3.4065~3.7312), and 5.1413 GHz; 115.4 MHz (5.0817~5.1971).

Table 2. Frequency Results

| Antenna | Frequency (GHz) | % Bandwidth | Antenna Gain (dB) |
|--------------------------|-----------------|-------------|-------------------|
| Microstrip Antenna | 5.15 | 3.81 | 4.83 |
| | 3.25 | 8.48 | 3.30 |
| Microstrip with SC-CSRR | 4.50 | 2.23 | 3.38 |
| | 5.22 | 4.14 | 3.85 |
| | 2.99 | 2.01 | 1.35 |
| Microstrip with DC-MCSRR | 3.57 | 8.70 | 3.67 |
| | 5.14 | 2.22 | 0.40 |

The radiation characteristics of each antenna in terms of the e & h field are shown in Figures 6-12. Realised gain is expressed throughout the patterns in all the figures. Figures 7, 8, 10 and 11 show a bidirectional pattern due to the simultaneous radiation of the patch antenna and the split rings on the ground plane, while Figures 6, 9, and 12 exhibits a directional pattern as only the patch antenna that radiates.

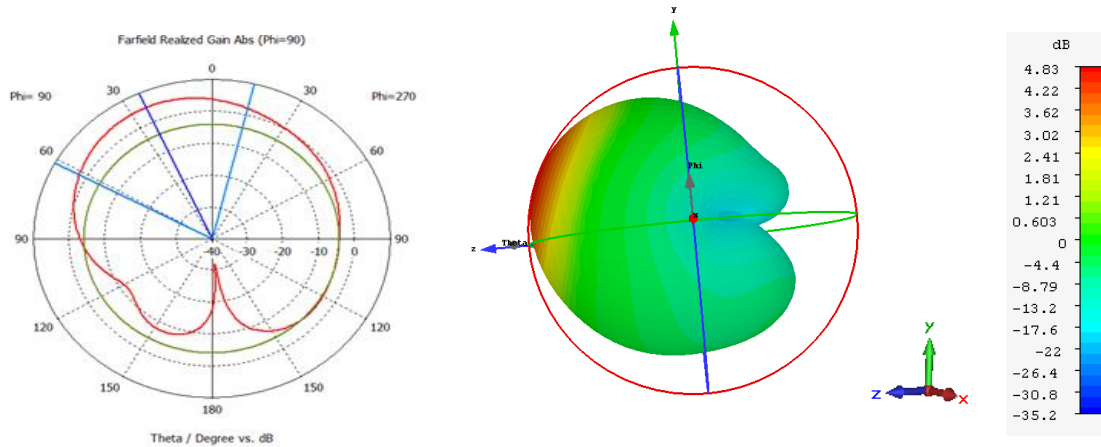

Figure 6. Simulated radiation patterns of Microstrip Antenna at 5.15GHz

3.1. Microstrip Antenna with SC-CSRR

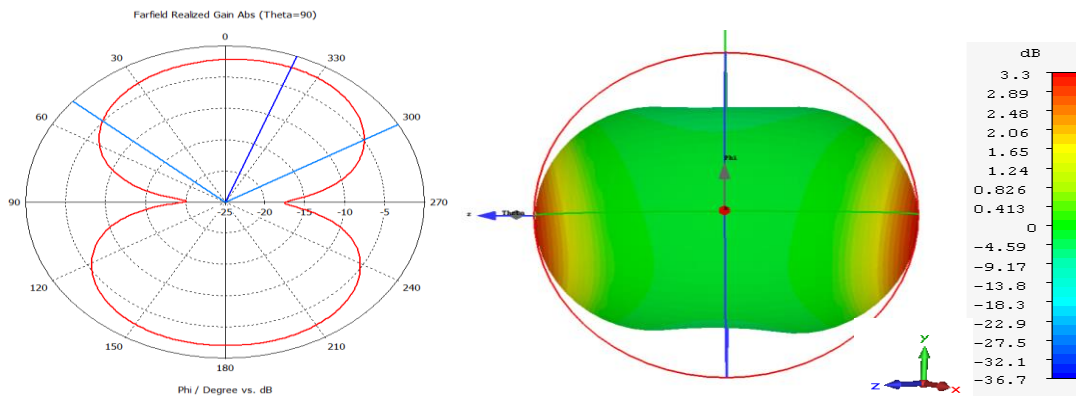

Figure 7. Simulated radiation patterns of Microstrip Antenna with SC-CSRR at 3.25GHz

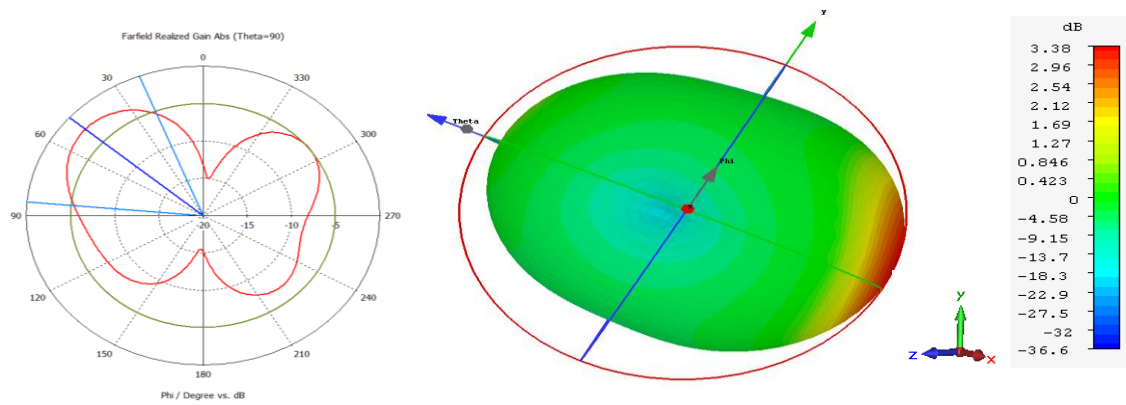

Figure 8. Simulated radiation patterns of Microstrip Antenna with SC-CSRR at 4.5GHz

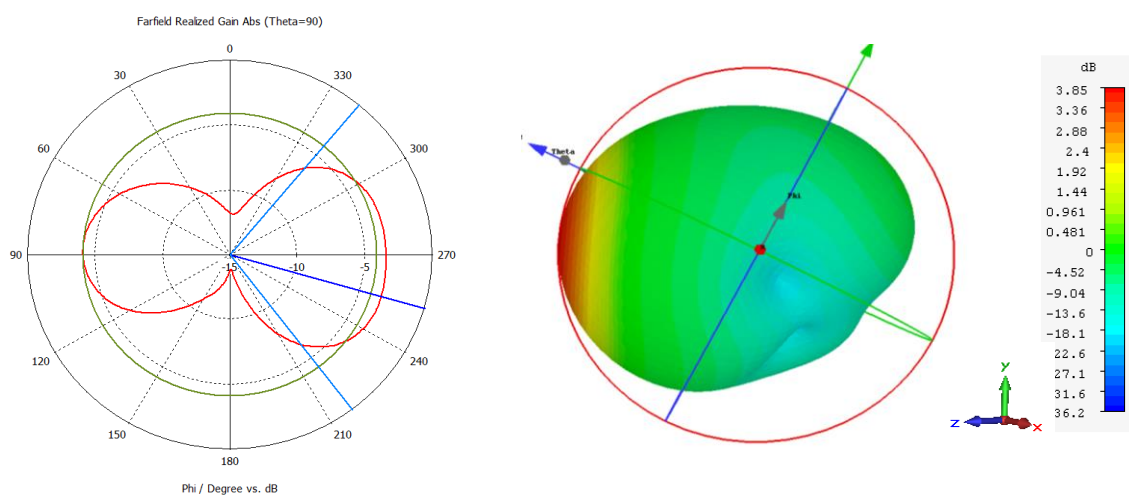

Figure 9. Simulated radiation patterns of Microstrip Antenna with SC-CSRR at 5.22GHz

3.2. Microstrip Antenna with DC-CSRR

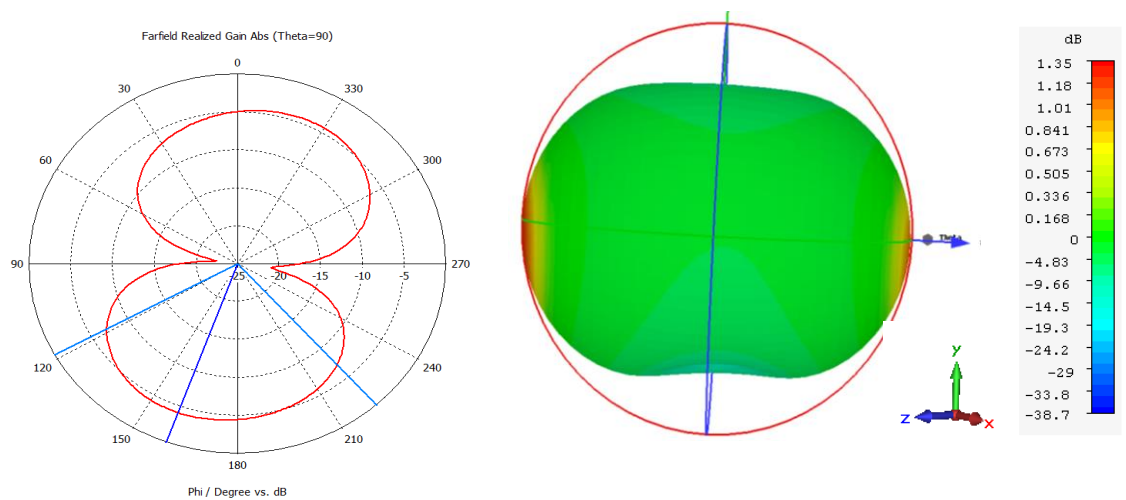

Figure 10. Simulated radiation patterns of Microstrip Antenna with DC-CSRR at 2.99 GHz

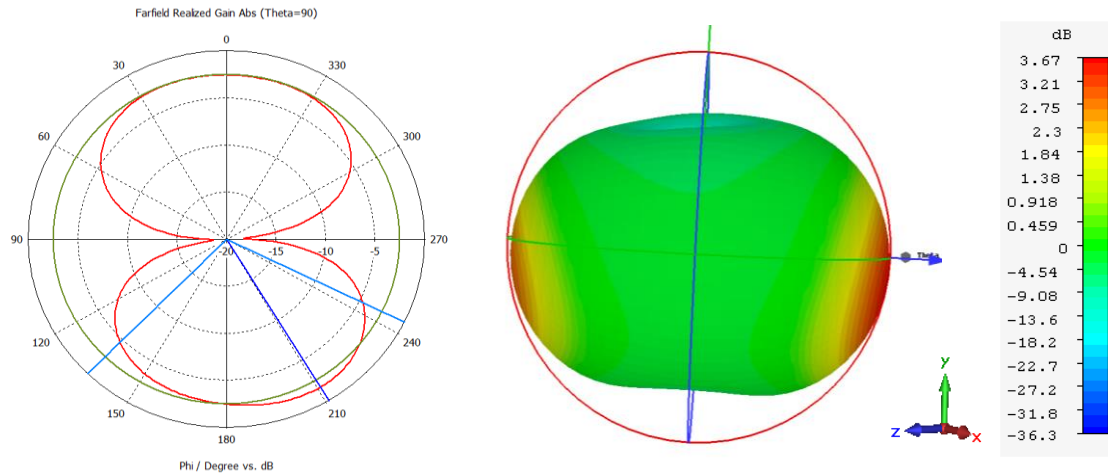

Figure 11. Simulated radiation patterns of Microstrip Antenna with DC-CSRR at 3.57GHz

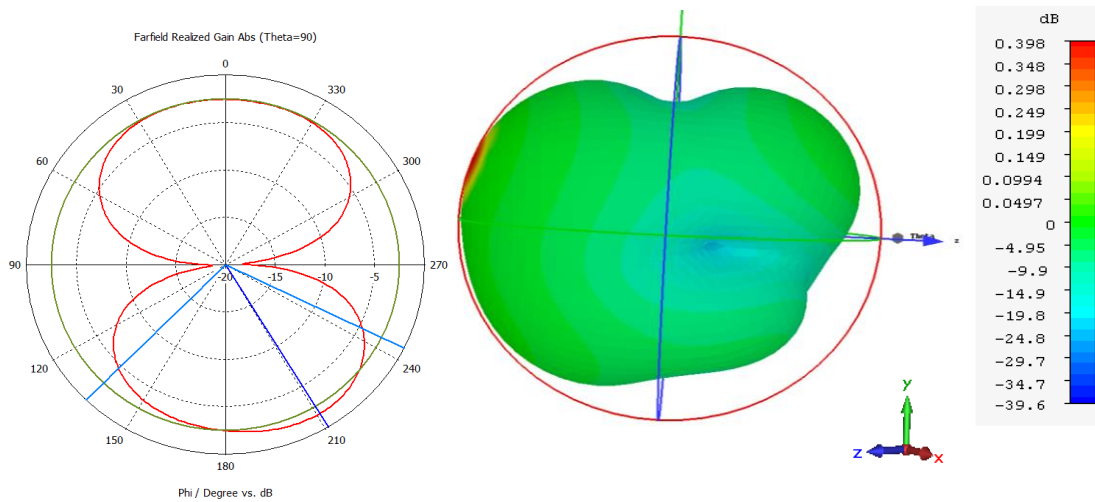

Figure 12. Simulated radiation patterns of Microstrip Antenna with DC-CSRR at 5.14GHz

4. Conclusion

A novel multiband metamaterial antenna based on the Multiple Circular Split Ring Resonator (MC-SRR) is proposed in this paper. By employing the CSRRs, multiple frequency bands were achieved. Both the design and methodology are detailed in this paper in addition to parameters selection. Based on the simulated results, the proposed antennas have shown good performance at the different frequency bands, the impedance matching, radiation patterns as well as gain. Microstrip with SC-CSRR has shown better performance in terms of gain as shown in table 2. Thus, a novel method to achieve miniaturization and multiband antenna using MC-SRR is hereby presented. Due to its simplicity in design & fabrication, light weight, low cost and compactness, the proposed antenna is suitable to be applied in wireless communication devices.

Acknowledgements

The authors would like to thank the Universiti Teknologi Malaysia (UTM), School of Postgraduate Studies (SPS) and ARFM Research Group, for their contribution towards undergoing this research work.

References

- [1] Firmansyah T et al. Bandwidth and Gain Enhancement of MIMO Antenna by using Ring and Circular Parasitic with Air-Gap Microstrip Structure. *TELKOMNIKA (Telecommunication Computing Electronics and Control)*. 2017; 15(3): 1155-1163.
- [2] Lo T et al. Miniature aperture-coupled microstrip antenna of very high permittivity. *Electronics Letters*. 1997; 33(1): 9-10.
- [3] Lee B, FJ Harackiewicz. Miniature microstrip antenna with a partially filled high-permittivity substrate. *IEEE Transactions on Antennas and Propagation*. 2002; 50(8): 1160-1162.
- [4] Er-rebyiy R et al. New Miniature Planar Microstrip Antenna Using DGS for ISM Applications. *TELKOMNIKA (Telecommunication Computing Electronics and Control)*. 2017; 15(3).
- [5] Boukarkar A et al. Miniaturized Single-Feed Multiband Patch Antennas. *IEEE Transactions on Antennas and Propagation*. 2017; 65(2): 850-854.
- [6] Yang M et al. Miniaturized patch antenna with grounded strips. *IEEE Transactions on Antennas and Propagation*. 2015; 63(2): 843-848.
- [7] Saghanezhad SAH, Z Atlasbaf. Miniaturized dual-band CPW-fed antennas loaded with U-shaped metamaterials. *IEEE Antennas and Wireless Propagation Letters*. 2015; 14: 658-661.
- [8] Constantine AB. *Antenna theory: analysis and design*. Microstrip Antennas, third edition, John Wiley & sons. 2005.
- [9] M Aminu-Baba MKAR, F Zubir, MFM Yusoff, A Bello Shallah. *Microstrip antenna with CSRR ground structure*. 2017 International Symposium on Antennas and Propagation (ISAP). IEEE: Phuket, Thailand. 2017: 1-2.
- [10] Mao CX et al. A Novel Multiband Directional Antenna for Wireless Communications. *IEEE Antennas and Wireless Propagation Letters*. 2017; 16: 1217-1220.
- [11] Sarkar D, K Saurav, KV Srivastava. Multi-band microstrip-fed slot antenna loaded with split-ring resonator. *Electronics Letters*. 2014; 50(21): 1498-1500.
- [12] Xie YH et al. A novel dual-band metamaterial antenna based on complementary split ring resonators. *Microwave and Optical Technology Letters*. 2012; 54(4): 1007-1009.
- [13] Rajni R, G Singh, A Marwaha. Modeling of Split Ring Resonators loaded microstrip line with different orientations. *International Journal of Electrical and Computer Engineering*. 2015; 5(6): 1363-1371.
- [14] Pendry JB et al. Magnetism from conductors and enhanced nonlinear phenomena. *IEEE transactions on microwave theory and techniques*. 1999; 47(11): 2075-2084.
- [15] Down SEGFU. *Balance Microwave LPF Responses with CSRRs*. Balance. 2017.