

Wireless Power Transfer by Using Solar Energy

M. Fareq¹, M. Fitra², M. Irwanto³, Syafruddin. HS⁴, N. Gomesh⁵, M. Rozailan⁶, M. Arinal⁷,
Y.M. Irwan⁸, J. Zarinatul⁹

Centre of Excellent for Renewable Energy (CERE), School of Electrical System Engineering,
Universiti Malaysia Perlis

e-mail : ¹mfareq@unimap.edu.my, ²mhdfitra@gmail.com, ³irwanto@unimap.edu.my,
⁴syafruddin@unimap.edu.my, ⁵gomesh@unimap.edu.my, ⁶rozailan@unimap.edu.my,
⁷arinal@unimap.edu.my, ⁸irwanyusoff@unimap.edu.my, ⁹zarinatuljamaliyah@gmail.com

Abstract

This project is based on how to transmit electrical power without any wires, with a small scale by using solar energy. The power is transferred wirelessly through an inductive coupling as an antenna. This method, we no longer need complicated with the cable passing around us, with wireless electricity we can charge and make wireless electricity as an input source to electronic equipment such as Handphone, MP3 Player, everything works use batteries source or electrical wiring. The experiments have been conducted and the wireless power transfer can be transfer energy up to 10 cm. with efficiency 0 - 10 cm ; 98.87% - 40%.

Keywords: wireless power, solar energy, inductive coupling

1. Introduction

Previously we already know the network connection data wirelessly or more often called a wireless or wifi, well at the moment scientists are developing a Wireless Electricity networks (Wireless Electricity).

The basic principle of how electrical energy can be transferred without wires is related to the phenomenon of resonance. Resonance is an object pulsate process because there are other objects that vibrate, this happens because an object vibrating at the same frequency with the frequency of affected objects. Inductive coupling is the resonant coupling between the coils of two LC circuits with the same resonant frequency, transferring energy from one coil to the other [1]. However, resonance coupling wireless power transfer is still in its infancy, whose theoretics and experimental analysis are in lacks, especially for efficiency analysis. During the wireless power transfer process, resonant frequency maybe change because resonant inductance changes with obstacles (such as magnetic objects,etc.), parasitical parameters, impacts of receiving loop, temperature rising in circuit and so on [2].

2. Research Method

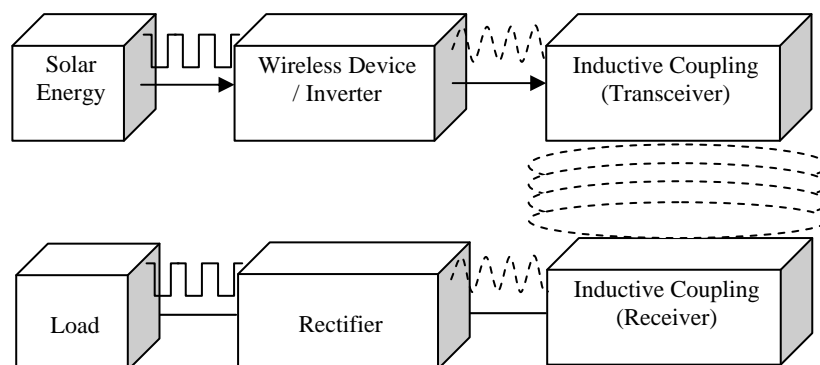

Figure 1. Block diagram wireless power transfer by using solar energy

The experimental setup of transceiver unit has been conducted. Energy transfer by electromagnetic induction to the receiver is via inductive coupling. The voltage sources to the transceiver were provided by solar cells. The inductive coupling is used as the antenna to wireless power delivered from the transmitting to the input of a receiver. Receiver unit, the bridge rectifier is used convert AC voltage to produces DC voltage and produce DC output. A capacitor is included in the circuit to act as a filter to reduce ripple voltage [3].

Wireless power or wireless energy transmission is the transmission of electrical energy from a power source to an electrical load without man made conductors. Wireless transmission using solar energy is wireless are inconvenient, no hazardous, and green technology [4].

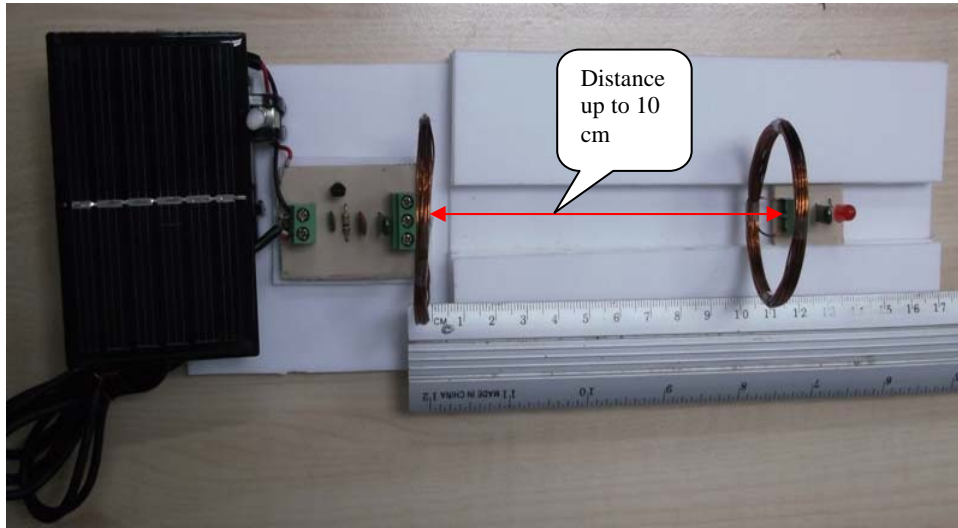

Figure 2. Experimental setup and collect data



Figure 3. Inductive Coupling in this case as the antenna of Wireless Power Transfer

A wireless power transmitter emits a magnetic field with the help of the coil with the same frequency emitted by wireless power receiver. In order for optimal impedance, cable reels used on both sides.

Cable reels also serves as the transmission gear bike. When the transmission gear uphill lowered in order to get more energy efficient, and vice versa. Wireless power receiver also determines its own voltage required to fit. Thus, the function of the adapter is not required. In addition, the wireless power transmitter also only emits as much energy as is required by the receiver.

These equations apply for when the length of the wire is much longer than the wire diameter [5], use this formula:

$$L = 0.21 \left(\ln \frac{4l}{d} - \frac{3}{4} \right) \quad (1)$$

Where :

L = inductance (μH)

l = length (mm)

d = wire diameter (mm)

3. Results and Analysis

An experiment has been conducted to get the WPT efficiency. The transmission inductive coupling was supply from direct current dc source. The difference in the distance between transmitter and receiver are varied to obtain the optimum distance for wireless power transmission.

Table 1. The difference data vs Solar DC output voltage and Frequency

Distance (cm)	Solar Source Volt	DC output Voltage (Volt)	Frequency (MHz)	Efficiency %
0	9	8.89	3.34	98.78
1	9	8.36	3.20	92.89
2	9	8.01	3.13	89.00
3	9	7.86	3.05	87.33
4	9	6.93	2.90	77.00
5	9	6.01	2.82	66.78
6	9	5.79	2.73	64.33
7	9	4.88	2.61	54.22
8	9	4.16	2.53	46.22
9	9	3.88	2.41	43.11
10	9	3.60	2.30	40.00

Table 1 shows the result of different distances with the voltage varied when the distance is different. The DC input source was used and the LED used as a Load.

Figure 4 and 5 shows the graph that has been created. The DC output voltage and frequency getting lower as the distance are higher. From this graph we can conclude that the wireless power transmission is higher when the distance is nearer.

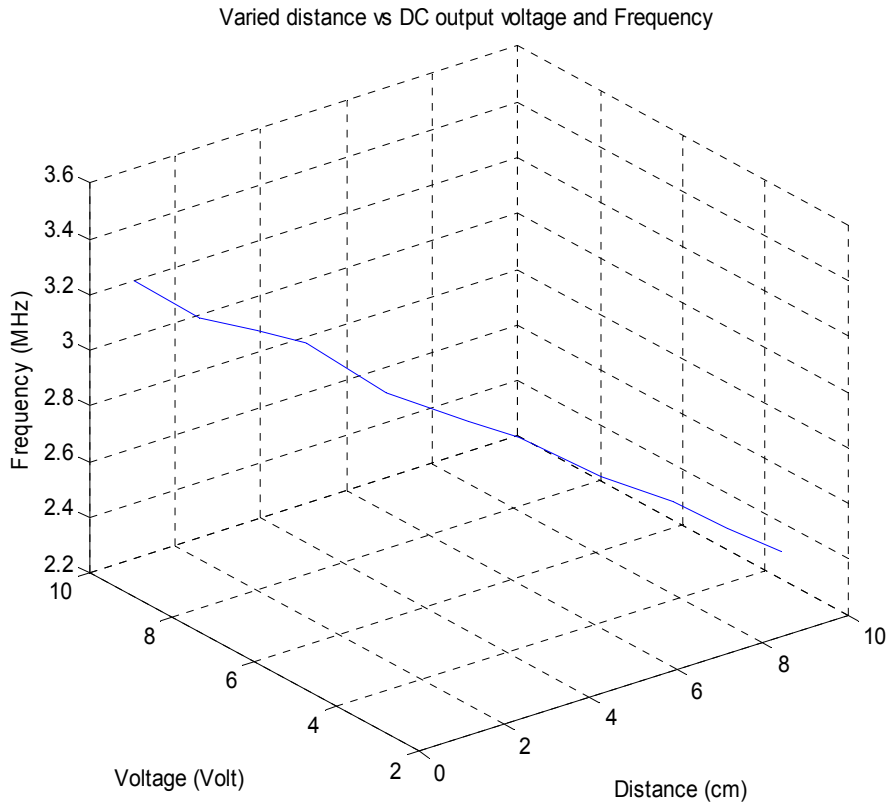

Figure 4. Graph of varied distance vs DC output voltage and frequency

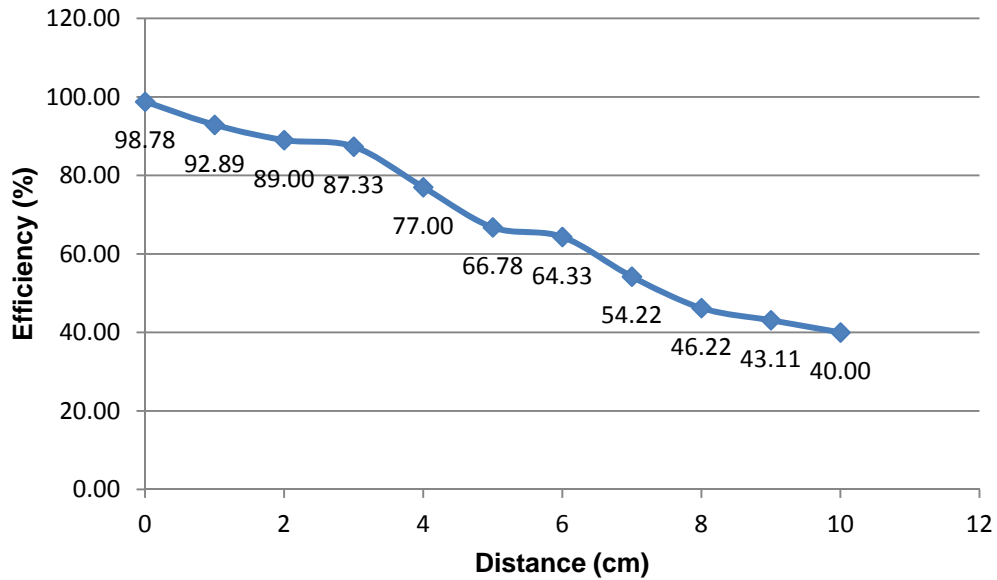

Figure 5. Graph of wireless power transfer efficiency and varied distance

To observe the exact waveform of an electrical signal in this study used oscilloscope. Oscilloscopes are electronic measuring instrument that serves to project the form of an electrical signal that can be seen and studied.

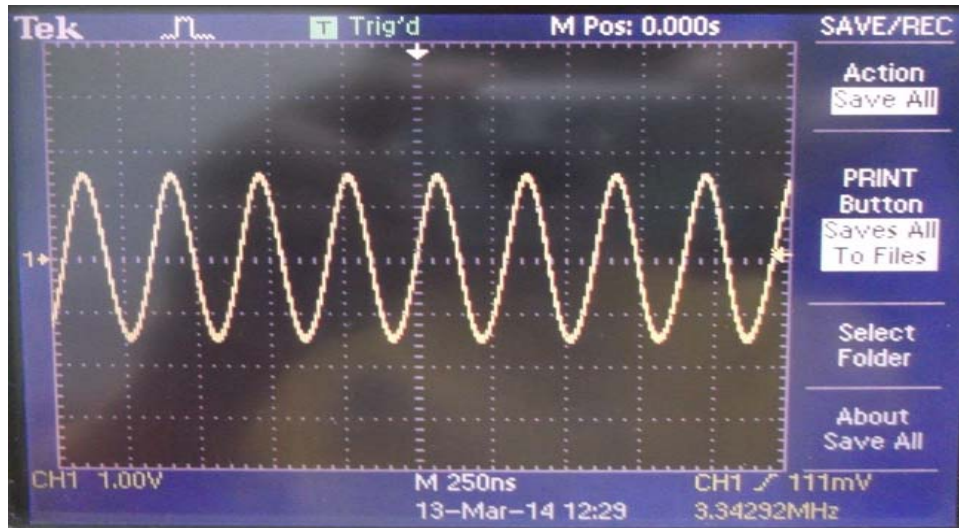

Figure 5. Waveform at Transceiver

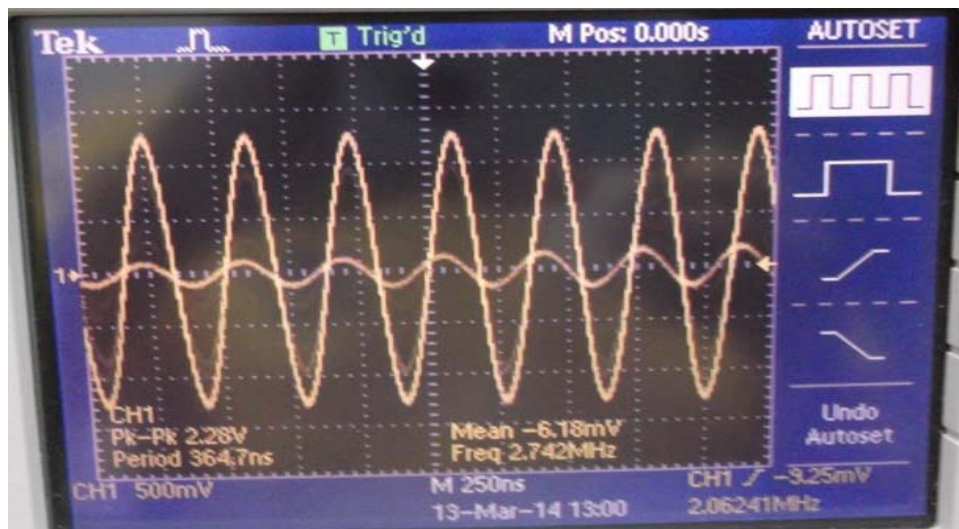

Figure 6. Waveform at Receiver

From Figure 5 and 6 waveform has measured from the point of inductive coupling which is the waveform is transmitted and received as well as sinewave. And then the sinewave is converted to DC waveform for DC load by using rectifier.

4. Conclusion

From the overall experiment conducted from wireless power transfer by using solar energy below conclusions are deduce. Base on experimental result, the study on wireless power transfer has much aspect in terms distance, range of frequency and result show the closer the distance, the voltage transferred is higher. From the experimental result in Table 1,

distance of the nearest is the most efficient wireless power transfer, and wireless power transfer by using solar energy can be reach is up to 10 cm with 3.60 Volt. The high efficiency is at 0 cm with 98.78% and the lower efficiency is at 10 cm with 40%.

References

- [1] Sourabh Pawade, Tushar Nimje, Dipti Diwase. Goodbye Wires: Approach to Wireless Power Transmission. *IJETAE*. 2012; 2(4).
- [2] Wenzhen Fu, Bo Zhang, Dongyuan Qiu. *Study on Frequency-tracking Wireless Power Transfer System by Resonant Coupling*. College of Electric Engineering South China University of Technology Guangzhou, P. R. China. 510641.
- [3] M. Fareq, M. Fitra. *Solar Wireless Power Transfer Using Inductive Coupling for Mobile Phone Charger*. IEEE conference Publications. 2014: 473-476. Doi: 10.1109 /PEOCO.
- [4] T.S. Hasarmani. *Wireless Power Transmission for Solar Power Satellite*. Department of Electrical Engineering. Bharati Vidyapeeth University's College of Engineering. 2011.
- [5] Rosa, Edward B. The Self and Mutual Inductances of Linear Conductors. *Bulletin of the Bureau of Standards*. 1908; 4(2): 301–344. doi:10.6028/bulletin.