

A new configuration of a printed diplexer designed for DCS and ISM bands

H. Setti^{*1}, J. Zbitou², A. El Hamichi³, A. Tribak⁴

^{1,3}FSTT, Electronics and Instrumentation Group, Tetuan, Morocco

²LMEET Laboratory FST of Hassan 1st University Settat Morocco, Morocco

⁴INPT, Microwave Group, INPT Rabat Morocco, Morocco

*Corresponding author, e-mail: hsetti1981@gmail.com

Abstract

This work presents a new study on the design of a microstrip diplexer configuration optimized and validated for ISM and DCS frequency bands. The achieved structure is based on microstrip technology, the goal was to design two printed bandpass filters one for ISM band and the other one for DCS frequency band. The two microstrip filters are associated by using a T-junction which permits to validate a diplexer in the frequency bands DCS-Band receiver [1.74–2 GHz] and ISM-Band transmitter [2.3–2.55 GHz]. The whole size of the final circuit is 130x50 mm². After the validation of the proposed diplexer into simulation we have fabricated and tested it by using VNA which permits to have a good agreement between simulation and measurements.

Keywords: antenna feed, diplexer, filter and planar structure, hairpin filter

Copyright © 2019 Universitas Ahmad Dahlan. All rights reserved.

1. Introduction

The main text format consists of a flat left-right columns on A4 paper (quarto). The Microwave filters and diplexers are essential components for the separation of channels and signals in modern communication systems [1, 2]. In this context, filters and diplexers are of particular interest in order to design new structures suitable for mobile systems which demand low level of power [3-5]. The goal at the end is to design new configurations of planar diplexers that can handle low levels of power and to function in different frequency bands [6, 7].

The main advantage of planar technology with respect to waveguides is its very high compactness [8, 9]. The manufacturing cost and the industrial reproducibility also make them competitive solutions with respect to the volume structures [10-12]. Diplexer finds many applications in communication systems. It has the distinction of using a single antenna power supply for transmission and reception. It gives rigorous conditions on selectivity, band rejection and insertion losses. Recently, several efforts have been proposed to design new diplexers having the best performances [13-18].

In planar technology, the design possibilities of diplexers are multiple. They are conditioned by the filter topologies used, the type of channel connection between them, the contiguity of the channels or the bandwidth of the circuit. As regards the topology of the filters, various conventional filter topologies are usable such as those with coupled lines, stubs in short circuit, open-circuit stubs and so on [19-23].

This paper comes with a new study on a printed microstrip diplexer which is optimized by using ADS "Advanced Design System". The circuit is based on coupled microstrip lines optimized into Momentum electromagnetic solver. The achieved diplexer presents good performances in terms of matching input impedance and isolation between the two frequency bands. The following sections will describe the different steps followed to optimize and to validate the final circuit.

2. Diplexer Design

The key of a diplexer is the design of bandpass filter, to do so we had to define the dimensions of each bandpass filter which will be used in the diplexer [24]. A bandpass filter is a cascade of a number of coupled line sections as shown in the following Figure 1. To calculate

the characteristics of the final bandpass filter we can use the equivalent circuit of the coupled line section as illustrated in Figure 2.

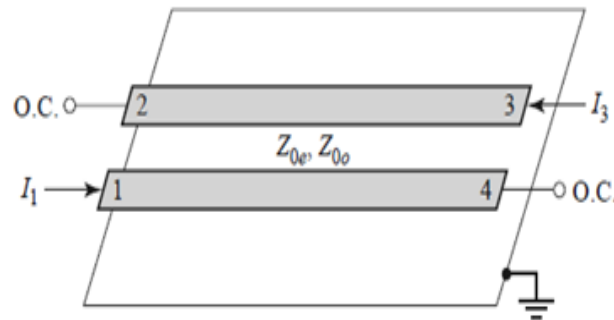

Figure 1. A two-port coupled line section having a bandpass response [25]

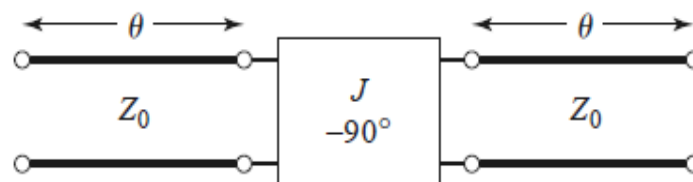

Figure 2. Equivalent circuit of the coupled line section [25]

the ABCD parameters of the equivalent circuit are given as follows [25]

$$\begin{aligned} \begin{bmatrix} A & B \\ C & D \end{bmatrix} &= \begin{bmatrix} \cos \theta & jZ_0 \sin \theta \\ \frac{j \sin \theta}{Z_0} & \cos \theta \end{bmatrix} \begin{bmatrix} 0 & -\frac{j}{J} \\ -jJ & 0 \end{bmatrix} \begin{bmatrix} \cos \theta & jZ_0 \sin \theta \\ \frac{j \sin \theta}{Z_0} & \cos \theta \end{bmatrix} \\ &= \begin{bmatrix} \left(JZ_0 + \frac{1}{JZ_0} \right) \sin \theta \cos \theta & j \left(JZ_0^2 \sin^2 \theta - \frac{\cos^2 \theta}{J} \right) \\ j \left(\frac{1}{JZ_0^2} \sin^2 \theta - J \cos^2 \theta \right) & \left(JZ_0 + \frac{1}{JZ_0} \right) \sin \theta \cos \theta \end{bmatrix} \end{aligned}$$

The idea was to design a diplexer based on the use of two bandpass filters, the technique used is the coupled lines, in order to miniaturize the final filter we have used a hairpin configuration of the microstrip lines. After many series of optimization based on random method integrated into ADS with fixed goals concerning the matching input impedance and the rejection bands we have validated two band pass filters as depicted in Figures 3 (a) and (b) as mentioned in Figure 3 (c), one centered at 1.8 GHz (DCS band: Rx-Filter), the other one (ISM band: Tx-Filter) at 2.45 GHz. An isolation level better than 20 dB is achieved.

As mentioned in simulation results the diplexer presents a transmission below 3 dB Figures 4 (a) and (b) and isolation below 20 dB and Figure 4 (c) which validated this circuit for DCS and ISM bands. After the validation of this diplexer mounted on an FR4 substrate with a thickness of 1.6 mm, a dielectric permittivity 4.4 and loss tangent of 0.025, into electrical and electromagnetic simulation, we have generated the layout as presented in Figure 5. The final circuit presents the dimensions of 130x50 mm².

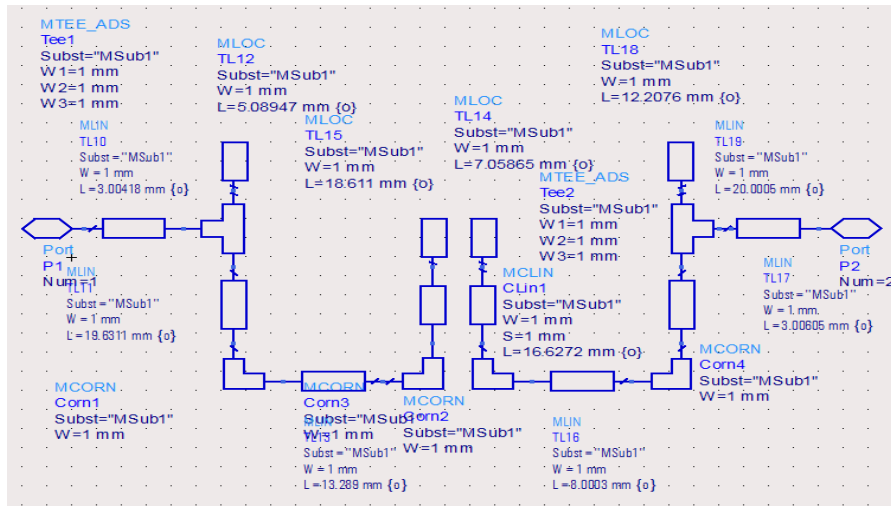

(a)

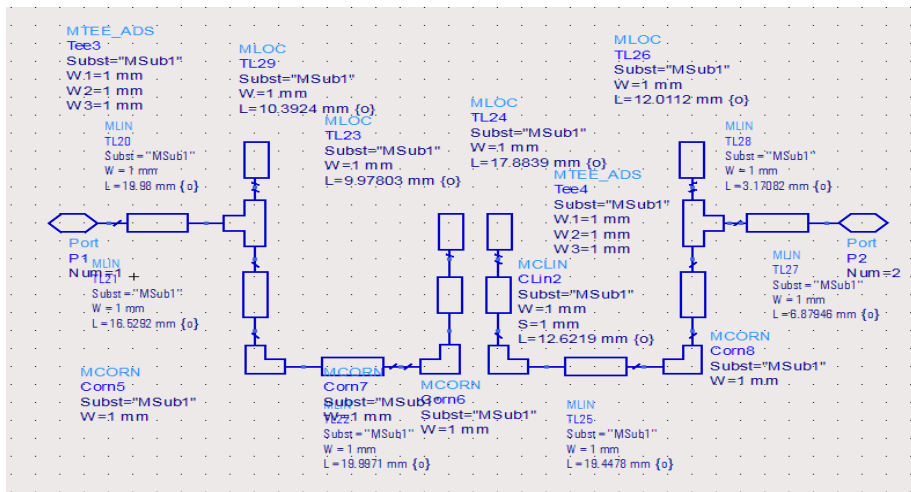

(b)

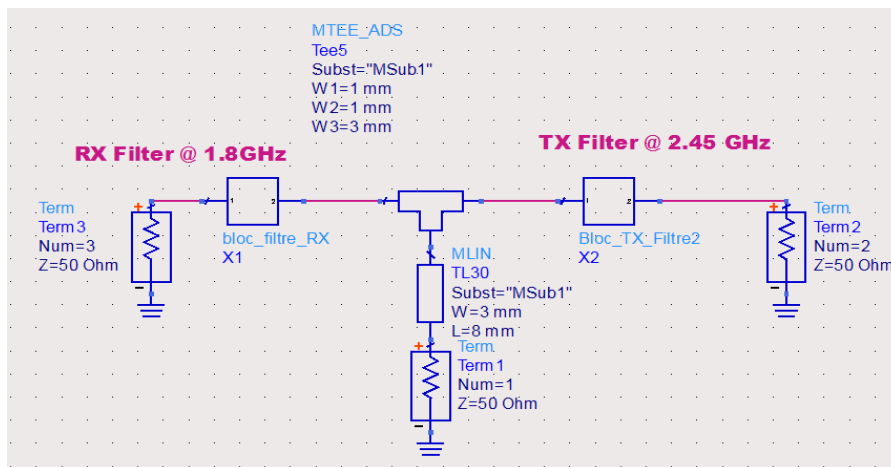

(c)

Figure 3. (a) Diplexer structure (b) Band-pass Rx-Filter @1.8 GHz (c) Band-pass Tx-Filter @2.45 GHz

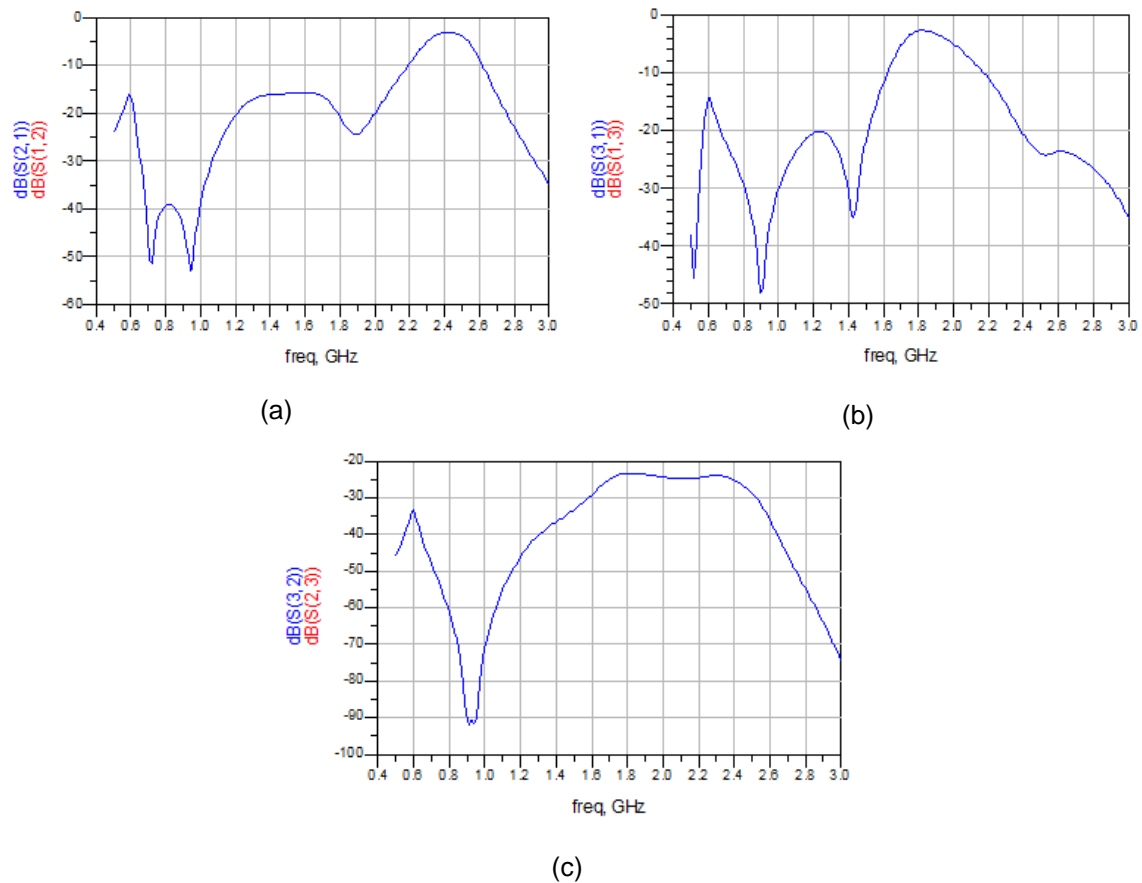

Figure 4. S-parameters of the diplexer according Figure 3
 (a) transmission coefficients between 1 and 2 (b) transmission coefficients between 1 and 3,
 (c) isolation between ports 2 and 3



Figure 5. Layout of the microstrip diplexer designed

3. Fabrication and Measurement

To verify the design and simulation results we have conducted the fabrication of the proposed diplexer using on the FR4 substrate. The fabrication is made by using LPKF Machine, the prototype based on realized of the circuit is shown in Figure 6. After the fabrication we have tested this circuit using Vector Network Analyser (VNA) with a calibration kit of 3.5 mm. As presented in Figure 7, we have obtained a good agreement between transmission coefficients and isolation with small different of bandwidth due to the condition of fabrication and test. As a

conclusion we can conclude that we have achieved a microstrip low cost diplexer which functions at DCS around 1.8 GHz and ISM at 2.45 GHz with a good isolation between TX and Rx frequency bands. The obtained results by measured procedure are in good concordance with those expected by simulation.

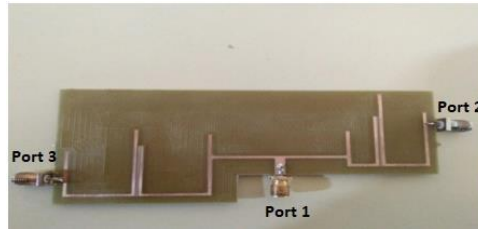

Figure 6. The fabricated printed diplexer

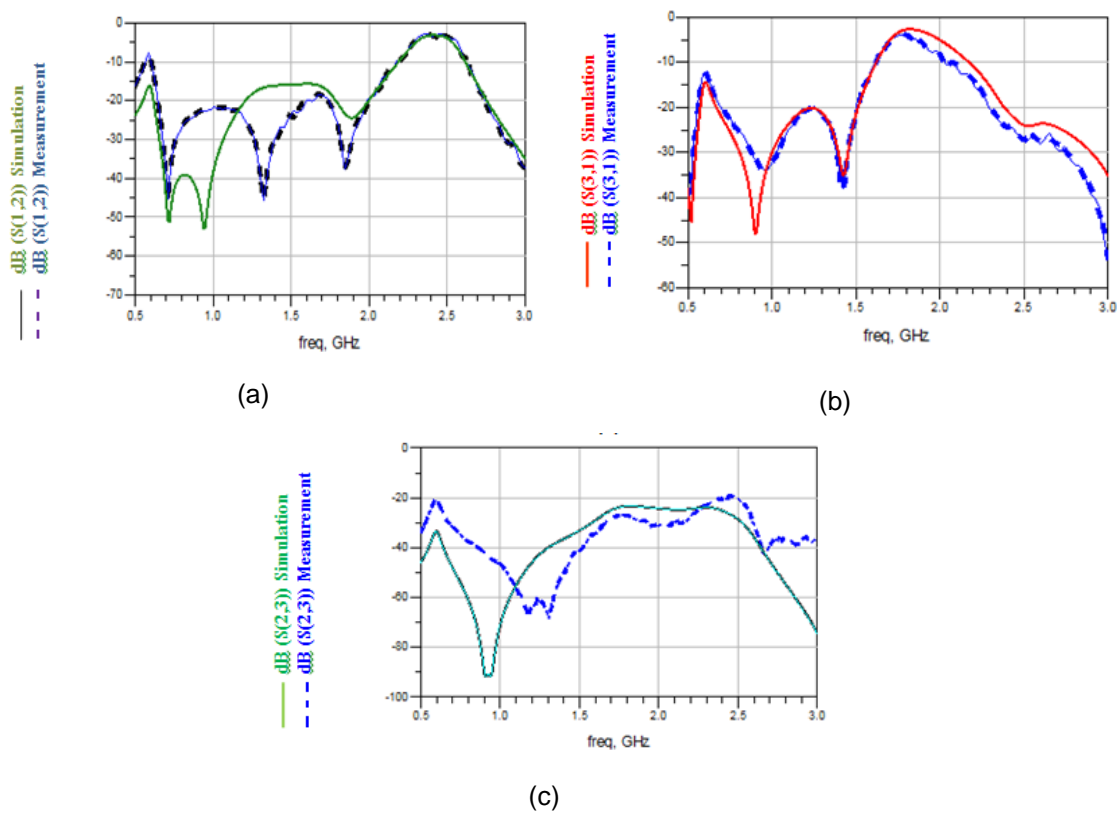

Figure 7. Comparison between simulation and measurement results
 (a) transmission coefficients between 1 and 2 (b) transmission coefficients between 1 and 3
 (c) isolation between ports 2 and 3

4. Conclusion

This work permits to validate a new diplexer structure which can be used for mobile communication systems. The final optimized and achieved circuit can operate in DCS and ISM bands with good performance in terms of transmission and isolation. The methodology followed to design the proposed diplexer can be followed to match the same circuit for other frequency bands. As a perspective, we propose to integrate active components as varactor diodes which act as a variable capacitance with reverse DC bias; this component can make this diplexer suitable for other frequency bands and to achieve, at the end, a reconfigurable microstrip diplexer based on varactor diodes.

References

- [1] MNS Swamy, K-L Du, *Wireless Communication Systems: From RF Subsystems to 4G Enabling Technologies*, New York: Cambridge University Press, 2010."
- [2] AZ Yonis. Performance analysis of IEEE 802. 11ac based WLAN in wireless communication systems. *International Journal of Electrical and Computer Engineering (IJECE)*. 2019; 9(2): 1131–1136.
- [3] A Rachakh, EA Larbi, Z Jamal, A Errkik. A Novel Configuration of a Microstrip Microwave Wideband Power Amplifier for Wireless Application. *TELKOMNIKA Telecommunication Computing Electronics and Control*. 2018; 16(1): 224–231.
- [4] SMA Motakabber, MN Haidari. Design of an Interdigital Structure Planar Bandpass Filter for UWB Frequency. *International Journal of Electrical and Computer Engineering (IJECE)*. 2018; 8(3): 1654–1658,.
- [5] B Nasiri, A Errkik, J Zbitou, A Tajmouati, L El Abdellaoui. A Compact Planar Low-Pass Filter Based on SRR Metamaterial. *International Journal of Electrical and Computer Engineering (IJECE)*. 2018; 8(6): 4972–4980.
- [6] HJ Tang, W Hong, J Chen, GQ Luo, K Wu. Development of Millimeter-Wave Planar Diplexers Based on Complementary Characters of Dual-Mode Substrate Integrated Waveguide Filters With Circular and Elliptic Cavities. *IEEE Transactions on Microwave Theory and Techniques*. 2007; 55(4): 776–782.
- [7] A Kiswantono. Multi Units of Three Phase Photovoltaic using Band Pass Filter to Enhance Power Quality in Distribution Network under Variable Temperature and Solar Irradiance Level. *International Journal of Electrical and Computer Engineering (IJECE)*. 2018; 8(2): 806–817.
- [8] Z Ouyang, MAE Andersen. Overview of Planar Magnetic Technology Fundamental Properties. *IEEE Trans. Power Electron*. 2014; 29(9): 4888–4900.
- [9] CK Madsen, JH Zhao, S Member. A General Planar Waveguide Autoregressive Optical Filter. *J. Light. Technol*. 1996; 14(3): 437–447.
- [10] N Marcuvitz. *Waveguide Handbook*, New York: McGraw-Hill 1951: 218-274.
- [11] Y Navarro, MS; Rozzi, TE; Lo. Propagation in a rectangular waveguide periodically loaded with resonant irises. *IEEE Trans. Microw. Theory Tech*. 1976; 28(8): 323–330.
- [12] S Doucha, M Abri, H A Badaoui, B Fellah. A Leaky Wave Antenna Design Based on Half-mode Substrate Integrated Waveguide Technology for X Band Applications. *International Journal of Electrical and Computer Engineering (IJECE)*. 2017; 7(6): 3467–3474.
- [13] MKSAU. ROSENBERG. *Compact diplexer design using different E-plane triplets to serve contiguous passbands with high interband selectivity*. 2006 European Microwave Conference. 2006.
- [14] S Srisathit, S Patisang, R Phromloungsri, S Bunnjaweht, S Kosulvit, M Chongcheawchamnan. High isolation and compact size microstrip hairpin diplexer. *IEEE Microw. Wirel. Components Lett*. 2005; 15(2): 101–103.
- [15] DHN Bui, TP. Vuong, B Allard, J Verdier, P Benech. Compact low-loss microstrip diplexer for RF energy harvesting. *Electron. Lett*. 2017; 53(8): 552–554.
- [16] Erdem Ofli, Riidiger Vahldieck. A Novel Compact Millimeter Wave Diplexer Erdem. *IEEE MTT-S, Dig. 2002*. 2002: 377–380.
- [17] A MORINI, T. ROZZI. Analysis of compact E-plane diplexers in rectangular waveguide. *IEEE Trans. Microw. Theory Tech*. 1839; 43(8): 1834–1839.
- [18] MA Sazali, NA Shairi, Z Zakaria. Hybrid Microstrip Diplexer Design for Multi-band WiMAX Application in 2.3 and 3.5 GHz Bands. *International Journal of Electrical and Computer Engineering (IJECE)*. 2018; 8(1): 576–584.
- [19] SC Lin, TL Jong. Microstrip bandpass filters with various resonators using connected- and edge-coupling mechanisms and their applications to dual-band filters and diplexers. *IEEE Trans. Microw. Theory Tech*. 2012; 60(4): 975–988.
- [20] R El Arif, M A Muslim, S H Pramono. Compact Stepped Impedance Resonator Bandpass Filter with Tunable Compact Stepped Impedance Resonator Bandpass Filter with Tunable Transmission Zeros. *TELKOMNIKA Telecommunication Computing Electronics and Control*. 2017; 15(4): 1689–1692.
- [21] KWUW MENG. A direct synthesis approach for microwave filters with a complex load and its application to direct diplexer design. *IEEE Trans. Microw. Theory Tech*. 2007; 55(5): 1010–1017.
- [22] M Guglielmi. Simple CAD Procedure for Microwave Filters and Multiplexers. *IEEE Trans. Microw. Theory Tech*. 1994; 42(7): 1347–1352.
- [23] F Darwis, AB Santiko, ND Susanti. Design of compact microstrip U shape bandpass filter using via ground holes. *TELKOMNIKA Telecommunication Computing Electronics and Control*. 2016; 14(1): 82–85.
- [24] RVS GMR LEVY. Design of microwave filters. *IEEE Trans. Microw. Theory Tech*. 2002; 50(3): 783–793.
- [25] David M. POZAR (University of Massachusetts at Amherst). *Microwave Engineering*. 1998.