

Comparative performance of optical amplifiers: Raman and EDFA

Khalis A. Mohammed, Basma M. K. Younis

Department of Computer Technology Engineering, Engineering Technical College, Northern Technical University, Iraq

Article Info

Article history:

Received Jan 31, 2020

Revised Feb 28, 2020

Accepted Mar 18, 2020

Keywords:

BER

EDFA

Eye opening

Quality factor

Raman

ABSTRACT

The in-line optical signal amplification is often used in optical communication systems to accomplish longer transmission distances and larger capacity. In this proposed paper, the operation of two types of optical amplifiers for 16×10 Gbps wavelength division multiplexing system had been examined by changing transmission distance from 10 to 200 km with a dispersion equals to 16.75 ps/nm/km. The analysis and design of such systems ordinarily includes many signal channels, nonlinear devices, several topologies with many noise sources, is extremely complex and effort-exhaustive. Therefore, theoretical studies with simulation CAD software of systems are become necessity to predict and optimize system performance. The comparison between EDFA and Raman has already explored by many researchers in varying ways in this work and to achieve above objectives, the OptiSystem software was used to design the proposed fiber optic communications system and to simulate results. Performance for the present system was evaluated for parameters like bit error rate (BER), quality factor (QF), total gain with eye opening factor. It was saw that EDFA provides better results, in the maximal transmission distance 64% better than Raman amplifier, 57.5% for amplification gain and 26.7% for maximum quality factor. As a future study a hybrid amplifier can produce better quality of amplification.

This is an open access article under the [CC BY-SA](https://creativecommons.org/licenses/by-sa/4.0/) license.



Corresponding Author:

Khalis A. Mohammed,

Department of Computer Technology Engineering, Engineering Technical College,

Northern Technical University, Mosul, Iraq.

Email: khalis_am@ntu.edu.iq or khalisbmk2004@gmail.com

1. INTRODUCTION

All over the world, the optical fiber communication systems are being widely used for transmitting video and data transmission purposes. Fiber optics only will be able to converge the challenge for spread over the universal telecommunication network make it remain to grow at an exponential speed. Optical amplifiers are important elements in progressive fiber telecommunications networks. They offer the means to offset the losses produced by the fiber transmission medium, the optical fiber basic elements placed in the broadcast path and the power split at optical splitters. So these amplifiers ease the extraordinary global abilities, long transmission durations and multipoint-to-multipoint connectivity necessary for act with increasing data sizes [1]. A brief account of the collection of researches and previous works related with those used in this work are listed below.

Article [2] shows that the semiconductor optical amplifiers have widely been adopted both by the research community and the industrial sector as a principal technological platform for the realization of a diverse range of applications with high performance. The optical amplifiers design models were

successfully designed and implemented into OptSim. The main motivation of the work in [3] is to optimize the optical amplifiers for different dispersion and transmission distance. The performance of optical amplifiers was evaluated using the eye patterns, BER measurement, eye opening and Q factor. The simulation results show behavior EDFA, SOA in terms of eye and power diagrams.

A 160-Gb/s OTDM transmission with all-channel modulation and all-channel simultaneous demultiplexing has been successfully simulated for the first time in article [4]. The MUX and DEMUX using of MZI switch strictly maintain the delay time between adjacent channels and offer high-temperature stability because they are hybrid integrated on MZI switch; they will, therefore, be the keys to future OTDM transmission systems. Authors in [5] obtained the longest transmission distances for a single in-line SOA and distributed Raman amplifier systems, also to classify some factors that are the most affect transmission distance. Results extend distance from 69 to 112 kilometers. They also describe factor that effected transmission in the system with the both proposed systems.

Performances of different optical amplifier types were combined then two most commonly hybrid amplifiers were used that can offer better action: an erbium doped fiber amplifier (EDFA), and a semiconductor optical amplifier (SOA), both in grouping to a distributed Raman amplifier (DRA). The results produce less distortions of the amplified signal [6]. Investigation also made for performance comparison of different hybrid optical amplifiers (Raman-EDFA, Raman-SOA, SOA-EDFA, EDFA-Raman EDFA). In a system consisted of 32 and 16 channels with 10 Gbps speed. Authors have documented the different hybrid amplifiers and their factors like quality, Max eye opening, Bit error rate and output power when changing number of channels [7].

A suggested configuration consists of many channels (16, 32 and 64) were examined by authors for different hybrid amplifiers performance in their proposed systems at speed of 10 Gbps. The quality factor, BER, eye opening and jitter at different number of channels were calculated. SOA-EDFA shows a QF performance as it can reach maximum distance of 260 km at 64 channels [8]. The performance of 64 channels of 10 Gbps WDM systems was discussed in [9] with backward multipump Raman amplifier to minimize its gain difference without using any gain flattening practical methods. They present system cost effective with only four utilized pumps. The maximum flat gain is 8.6 dB . The noise figure was greater than 8 dB were reached for this wide bandwidth without using techniques of gain flattening.

Our paper is organized into five sections. We focused on a simulation study of optical amplifiers for performance and comparison purpose, section 2 gives an overview on optical amplifiers used in this work, moreover section 3 described the simulation setup of optical amplifiers. Section 4 gives analysis of observed results after simulation. Section 5 gives the conclusion of QF, total gain, and eye opening factor for 16 channels WDM system. It was observed through simulation that EDFA provided the best performance in terms of total gain, QF, BER and eye-opening factor.

2. RESEARCH METHOD

Optical amplifiers are core devices in optical amplification transmission system [10, 11], since they amplify an optical signal directly, therefor no need to an electrical signal conversion, In this paper two types of optical amplifier are used as illustrated in sections below:

2.1. Raman amplifier-average power model

Raman amplifiers (RA) have become one of the most encouraging technologies for the next group of fiber amplifiers, mostly due to their flexibility in bandwidth design [12]. Nevertheless, the simulation techniques that are commonly used for RA's have demanded exhaustive computational time, due to the use of direct integration of the coupled differential equations that describe the RA behavior [13, 14]. The coupled differential equations have the shape observed in (1). A similar set of equations, describing the backward propagation, is solved at the same time we solve the forward equations written below [15-17]. More details about in (1) with the physical effects taken into account for this amplifier can be found in [16],

$$\begin{aligned} \frac{dP_f(z,v)}{dz} &= \alpha(v)P_f(z,v) + \gamma(v)P_b(z,v) + P_f(z,v) \sum_{v<\zeta} \frac{g_r(v-\zeta)}{K_{eff}A_{eff}} [P_f(z,\zeta) + \\ P_b(z,\zeta)] h\Delta v \sum_{v<\zeta} \frac{g_r(v-\zeta)}{A_{eff}} [P_f+P_b] \left[1 + \exp\left(\left[\frac{h(\zeta-v)}{kT}\right] 1\right)^{-1} \right] - P_f(z,v) \sum_{v<\zeta} \frac{g_r(v-\zeta)}{K_{eff}A_{eff}} \frac{v}{\zeta} [P_f(z,\zeta) + P_b(z,\zeta)] - \\ 2hv\Delta v P_f(z,v) \sum_{v<\zeta} \frac{g_r(v-\zeta)}{A_{eff}} \left[1 + \exp\left(\left[\frac{h(v-\zeta)}{kT}\right] 1\right)^{-1} \right] \end{aligned} \quad (1)$$

The idea behind this technique is first to split the amplifier into a series of small segments, and then to use the minor signal wave solution in each section in (3). In order to eliminate the dependence in a small segment length, average powers in each section are introduced in (4). So, basically, we rearranged some terms of the original in (1) and reduce equations to a simplest form, suitable for our analysis, can be written as [18]:

$$\frac{dP_f(z,v)}{dz} = A(z,v)P_f(z,v) + B(z,v) \quad (2)$$

where

$$A(z,v) = -\alpha(v) + \sum_{v < \zeta} \frac{g_r(v-\zeta)}{K_{eff}A_{eff}} [P_f(z,\zeta) + P_b(z,\zeta)] - 2hv\Delta v \sum_{v < \zeta} \frac{g_r(v-\zeta)}{A_{eff}} \left[1 + \frac{1}{\exp\left(\left[\frac{h(v-\zeta)}{kT}\right]-1\right)^{-1}} \right] \quad (2a)$$

$$B(z,v) = \gamma(v)P_b(z,v) + hv\Delta v \sum_{v < \zeta} \frac{g_r(v-\zeta)}{A_{eff}} [P_f(z,\zeta) + P_b(z,\zeta)] \left[1 + \frac{1}{\exp\left(\left[\frac{h(v-\zeta)}{kT}\right]-1\right)^{-1}} \right] \quad (2b)$$

substituting $P_f(z,\zeta)$, $P_b(z,\zeta)$, in (2a), (2b) in each lump by average powers in the lump, coefficients $A(z,v)$, $B(z,v)$ are independent of z solution for (2) can be written as [18]:

$$P_f(z_o + H, v) = P_f(z_o, v) \exp(A(v)H) + \frac{B(v)}{A(v)} [\exp((A(v)H) - 1)] \quad (3)$$

where H is length of the lumps.

Within each lump, powers $P_f(z, \zeta)$, $P_b(z, \zeta)$ must be replaced by average powers [18],

$$\langle P_{f,b}(v) \rangle = P_{f,b}^{in} \frac{G-1}{1nG} + \frac{B(v)}{A(v)} \left[\frac{G-1}{1nG} - 1 \right] \quad (4)$$

where $P_{f,b}^{in}$ are forward and backward propagating input powers to the lump, and the gain is given by: $G = \exp(A(v)H)$. The user is responsible to guarantee that the term $A(v)$ does not become zero. For example, it is impossible to simulate the chromatic dispersion of just one signal if the attenuation is not considered, hence the term $A(v)$ will become zero.

2.2. Erbium doped fiber amplifier (EDFA)

This optical amplifier repeater employed to amplify the optical signals. The main difference from the previous one is related to the amplifier pump scheme selection. The used EDFA routines are numerically solved under stationary conditions [19], these equations are:

$$\frac{\partial N_2(z,t)}{\partial t} = \frac{N_2(z,t)}{\tau} - \frac{1}{A_{eff}} \sum_{n=1}^M \{ \Gamma_n [(\sigma_n^e + \sigma_n^a) N_2(z,t) - \sigma_n^a] \} [P_n^+(z,t) + P_n^-(z,t)] \quad (5)$$

$$N_1 + N_2 = 1 \quad (6)$$

$$\frac{\partial P_n^\pm(z,t)}{\partial z} = u_n \{ \rho \Gamma_n [(\sigma_n^e + \sigma_n^a) N_2(z,t) - \sigma_n^a - \alpha] \} P_n^\pm(z,t) + 2\rho \Delta v N_2 \Gamma_n \sigma_n^e \quad (7)$$

The confinement factor Γ_n (which is used in simulation program in this paper) is given by [19]:

$$\Gamma_n(v) = \frac{\int_0^b |E(r,v)|^2 r dr}{\int_0^\infty |E(r,v)|^2 r dr} \quad (8)$$

solving (5-7) under stationary conditions allows designers to conclude the amplifier performance features. The fiber parameters such as core and Er doping radius, Er metastable lifetime, numerical aperture, Er ion density, loss at 980 nm and 1550 nm, and the fiber length are all required as input values. The absorption and emission cross-section are moreover required as input files.

3. SIMULATION MODEL

OptiSystem [20, 21] is used in this work since it is an innovative simulation package for optical communication system which was established by Optiwave company to converge the educational and practical necessities of the system designers, engineers and researchers [22-24]. As shown in Figure 1. Sixteen transmitters are used at a speed of 10 Gbps in order to study the performance of the Optical amplifiers

under test. Input signals were fed from data source to the laser modulator. Which are modulated through a carrier optical output signal transmittance. These signals were spread using transmission line to which the optical analyzer and spectrum was attached. Then the optical amplifier is located which consists either Raman or EDFA.

Other amplifiers can also be chosen according to the requirements. Later, the receiver was attached to notice all signals and transformed to electrical signal. Optical amplifiers were applied with many channels. The optical signal was transmitted and measured using several distances with 16 channels. Lots of factors like eye opening, quality factor, and gain were determined at different channels and best one of it is calculated at a number of channels. These signals were amplified using different amplifiers. The gain was measured by optical spectrum and WDM analyzer. The modulated signal was transformed into original signal using PIN photo-detector in the receiver. An oscilloscope and eye diagram analyzer were used to measure the quality factor and the eye opening at the receiver side. While Figure 2 shows the detailed model, which had been build using OptiSystem simulator.

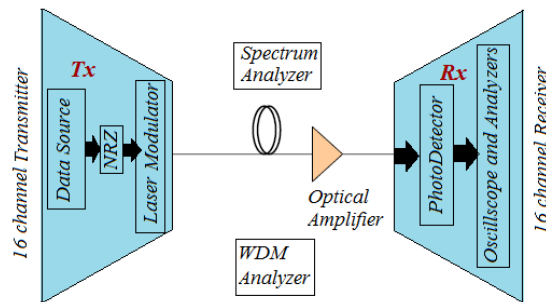

Figure 1. Block diagram of the proposed system

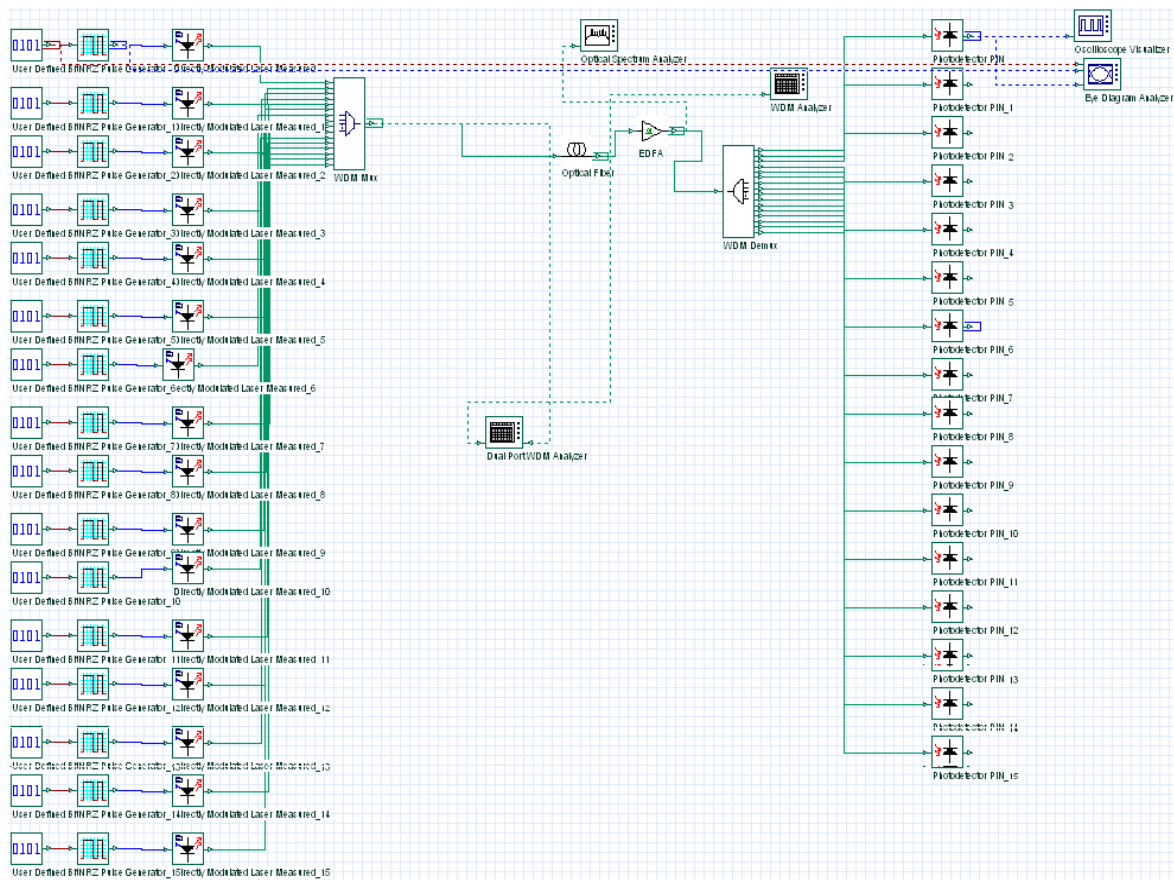

Figure 2. OptiSystem simulation model

4. RESULTS AND ANALYSIS

We focus our attention on the results obtained with the scheme described in Figure 1. Then the first step is building simulation model of Figure 2 using OptiSystem. Second, we start to increase the fiber length and measure performance metrics as shown Figure 3. Third and in order to estimate the system performance the eye diagrams should be analyzed; this is done using Figure 4. The eye diagram is a powerful time domain tool for assessing the quality of the received signal and for analyzing the signal distortions. It can give much information on the timing jitter, the system rise time, and the signal amplitude distortions [6]. Fourth the fiber length, gain and Max Quality factor are listed in Table 1. Finally relation between fiber length and gain is shown in Figure 5.

Optical amplifiers Raman and EDFA have been studied for 16×10 Gbps Wavelength Division Multiplexing system in the word of received maximum quality factor (QF), eye opening factor, bit error rate (BER) and total gain. To investigate the system performances, results from the first channel have been taken. By examining Figure 3 the variation of QF and BER with various length for 16 channel system can be notice. Maximum QF was obtained by EDFA which was the similar practically for entire range and begin reductions after 128km its worst distance at 200 km is 8. Raman have comparably lower QF starting from 19 to 12.7 for distance range from 20 to 80 km and in last at 128 km has lowest value equals 2.4. From the simulation result, it was seen that maximum eye-opening factor was obtained from EDFA was 90.5527%, while this factor was equal to 90.2788% for Raman amplifier for 60km. Also, eye diagram for different optical amplifiers with 60 km fiber and 16 channels are shown in Figure 4.

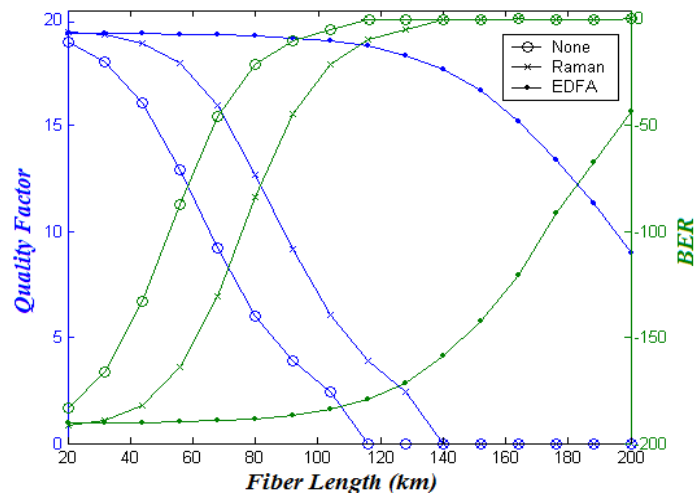

Figure 3. Quality factor (QF) and Bit error rate (BER) as a function of fiber length for 16 channels

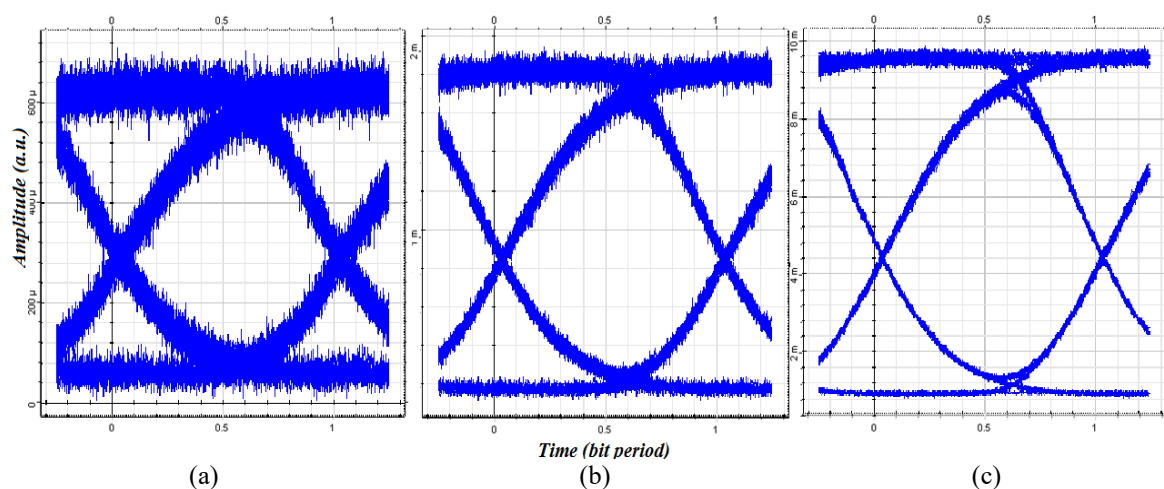

Figure 4. Eye diagram of optical layout used in the simulation without optical amplifier and with Raman and EDFA amplifiers; (a) without optical amplifier, (b) Raman and (c) EDFA

The maximum gain in transmission distance is obtained, that can be accomplished by EDFA or Raman. System maximum transmission distance is necessary to find first without optical amplification. therefore, the maximum length of the fiber was found. Simulation results are shown in Table 1. The graph result for total gain is shown in Figure 5. The same techniques (OptiSystem) used to obtain results in this work could be also used to improve a new hybrid amplifier with better quality of amplification [6, 8, 25].

Table 1. Simulation results

Amplifier type	None	EDFA	Raman
Fiber length km	104	200	128
Amplifier Gain	none	40	23
Max Quality factor	2.4	8.9	2.4

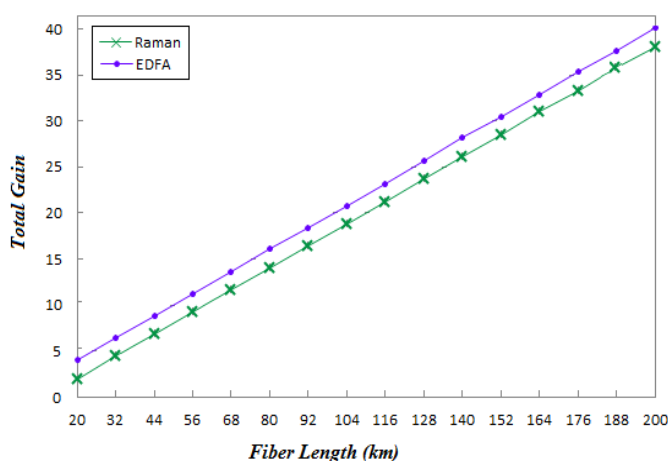

Figure 5. Total gain versus fiber length for the both optical amplifiers, Raman and EDFA

5. CONCLUSION

The proposed optical amplifiers models were successfully designed and implemented via OptiSystem simulator. The main objective of this research was to investigate which optical amplifier, for several transmission distance to be used properly in terms of its parameters. The performance of optical amplifier was calculated via total gain, BER amount, eye opening and quality factor. The simulation results showed an interesting performance of EDFA, Raman in relations of eye and gain diagrams.

The proposed configuration consisted of 16 channels with the same bit rate transmission. The results showed that EDFA was enabling to increase the maximal transmission distance to be between 120 to 200 km, and a promising tool for future. While Raman amplifier extended transmission distance to 140 kilometers. It was perceived through simulation that EDFA provided the best behavior in relations of total gain, QF, BER and eye-opening factor. So, Since the EDFA generated less signal distortions, then in future Implementation of hybrid amplification using EDFA and other one can produce better quality of amplification.

REFERENCES

- [1] P. Urquhart, "Advances in Optical Amplifiers," Croatia: *InTech*, 2011. doi: 10.5772/571
- [2] Kyriakos E. Zoiros, "Special Issue on Applications of Semiconductor Optical Amplifiers," *Applied Sciences*, 2017.
- [3] H. Bhagwan, T. Gulati and B. Rawat, "Evaluation of Optical Amplifiers," *International Journal of Engineering Research and Applications (IJERA)*, vol. 2, no. 1, pp. 663-667, 2012.
- [4] S. Kumar, I. Bala, and A. Singhal, "Optical Fiber Communication System Performance Using MZI Switching," *International Journal of Soft Computing & Engineering (IJSCSE)*, vol. 2, no. 3, pp. 98-107, 2012.
- [5] S. Olonkins, et. al, "Comparison of Semiconductor Optical Amplifier and Discrete Raman Amplifier Performance in DWDM Systems," *Electronics and Electrical Engineering*, vol. 7, no. 123, pp. 133-136, 2012.
- [6] V. Bobrovs, et. al, "Comparative performance of Raman-SOA and Raman- EDFA hybrid optical amplifiers in DWDM transmission systems," *Indian Journal of Pharmaceutical Sciences*, vol. 8, no. 39, pp. 1898-1906, 2013.
- [7] P. Jain, B. Koushal, and S. Jain, "Performance analysis of different Hybrid optical amplifier due to varying Transmission distance at 10 Gbps," *International Journal of Emerging Technologies in Computational and Applied Sciences*, pp. 246-250, 2013.

- [8] S. Bhaskar, M. and R. Kaur, "Performance Comparison of different hybrid amplifiers for different numbers of channels," *International Journal of Advanced Computer Science and Applications*, pp. 19-25, 2011.
- [9] Dipika D. Pradhan and Abhilash Mandloi, "Performance Analysis of Flat Gain Wideband Raman Amplifier for S+C and C+L Band DWDM System," *Hindawi Advances in Optoelectronics*, vol. 2018, pp. 1-7, 2018.
- [10] L. Galdino, A. Edwards, M. Ionescu, J. James, W. Pelouch, E. Sillekens, D. Semrau, D. Lavery, R. I. Killey, S. Barnes, P. Bayvel, and S. Desbruslais, "120 Tbit/s Transmission over Single Mode Fibre using Continuous 91 nm Hybrid Raman-EDFA Amplification," *physics.app-ph, arXiv:1804.01845v1*, 2018.
- [11] Khalis A. Mohammed, "Mole Fraction Effect on Semiconductor Optical Amplifier Specifications," *Al-Rafidain Engineering*, vol. 18, no. 6, pp. 61-69, 2010.
- [12] Mohammed N. Islam, "Raman Amplifiers for Telecommunications 1: Physical Principles," *Springer, USA*, 2004.
- [13] Vijay Rao Kumbhare, "Raman Amplifier Characteristics with Variation of Signal Power and Pump Power with and Without Amplified Spontaneous Emission," *IJCA Proceedings on International Conference on Recent Trends & Advancements in Engineering Technology*, no. 2, 2015.
- [14] Song Hu, Hanyi Zhang, and Yili Guo, "Stiffness analysis in the numerical solution of Raman amplifier propagation equations," *Optical Society of America (OSA) publishing*, vol. 12, no. 8, pp. 1656-1664, 2004.
- [15] Desurvire, "Erbium-doped fiber amplifiers: principles and applications," *Wiley-Interscience*, 1994.
- [16] X. Liu and B. Lee, "A fast and stable method for Raman amplifier propagation equations," *Optical Society of America (OSA) publishing*, vol. 11, no. 18, pp. 2163-217, 2003.
- [17] C. Headley and G. P. Agrawal, "Raman Amplification in Fiber Optical Communication Systems," *Elsevier Academic Press, USA*, 2005.
- [18] B. Min, W. J. Lee, and N. Park, "Efficient Formulation of Raman Amplifier Propagation Equations with Average Power Analysis," *IEEE Photonics Technology Letters*, vol. 12, no. 11, pp. 148-1488, 2000.
- [19] C. R. Giles and E. Desurvire, "Modeling erbium-doped fiber amplifiers," *Journal of Light-wave Technology*, vol. 9, no. 2, pp. 271-283, 1991.
- [20] Optiwave Corporation, "OptiSystem Getting Started," *Optical Communication System Design Software*, 2003.
- [21] Sawsan A. Abdul- Majid, "Software Simulation FWM in WDM Optical Communication Systems," *Journal of Kirkuk University – Scientific Studies*, vol. 6, no. 1, pp. 74-90, 2011.
- [22] X. Yang, Y. Hechao, "The Application of OptiSystem in Optical Fiber Communication Experiments," *Proceedings of the Third International Symposium on Computer Science and Computational Technology (ISCCT '10) China*, pp. 376-378, 2010.
- [23] Jihua Zhu, Xuanlu Xiao, Yuan Luo "An experiment teaching method based on the Optisystem simulation platform," *Proc. SPIE 10452, ETOP*, 2017.
- [24] Khalis A. Mohammed, Maan M. Shaker and Mozahim I. Azawe, "Dynamic Simulations of Semiconductor Optical Amplifier by Analytical Solution of Traveling-Wave Equation," *Al-Rafidain Engineering*, vol. 17, no. 1, pp. 26-331, 2009.
- [25] Karasek et al., "Hybrid Amplifiers Designed for Local Area Networks," *IEE Proc.-Optoelectron.*, 2001.

BIOGRAPHIES OF AUTHORS



Khalis Asa'ad Mohammed works at Northern Technical University/Engineering Technical College Mosul-Iraq/Department of Computer Technology Engineering. He received B.Sc. degree in electrical engineering/Electronic and Communication Engineering from University of Mosul-Iraq in 1990, M.Sc. degree in Electronic and Communication Engineering from University of Mosul-Iraq in 2001. His research interests and activity are Optical Communication and Digital Electronics. He teaches digital Electronics, digital techniques and digital circuits for undergraduate students.

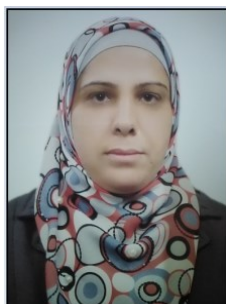

Basma MohammedKamal Younis works at Northern Technical University/Engineering Technical College-Mosul- Iraq/Department of Computer Technology Engineering. She received B.Sc. degree in electrical engineering/Electronic and Communication Engineering from University of Mosul-Iraq in 1995, M.Sc. degree in computer engineering from University of Mosul- Iraq in 2000 and Ph.D. degree in computer engineering/Microprocessors Architecture from University of Mosul-Iraq in 2007. Her research interests and activity are Embedded System Design using FPGA and Computer Graphics. Now, she teaches Advanced Digital Electronics, Microprocessors Based Systems and Embedded Systems for postgraduate and undergraduate students.