

Power loss analysis of current-modules based multilevel current-source power inverters

Suroso^{*1}, Winasis², Daru Tri Nugroho³, Wahyu Tri Cahyanto⁴

^{1,2,3}Department of Electrical Engineering, Jenderal Soedirman University, Indonesia

⁴Department of Physics, Jenderal Soedirman University, Indonesia

*Corresponding author, e-mail: suroso.te.unsoed@gmail.com

Abstract

A power loss analysis of multilevel current-source inverter (MCSI) circuits developed from two basic configurations of three-level current-source inverters, i.e. H-bridge and common-emitter inverter configurations is presented and discussed. The first circuit topology of the MCSI is developed by using DC current modules connected to the primary three-level H-bridge inverter. The second MCSI circuit is created by connecting the current-modules to a three-level common-emitter inverter. The DC current modules work generating the intermediate level waveform of the inverter circuits. Power loss analysis of the both topologies was carried out to explore the efficiency performance of the inverter circuits. The results showed that for the H-bridge and common-emitter MCSI using DC current modules, the amount of conduction losses in the inverter circuits could be diminished when the level number of AC output current increase. The measurement test results have also proved that using these MCSI topologies, the power conversion efficiency will also increase.

Keywords: efficiency, inverter, power inductor

Copyright © 2019 Universitas Ahmad Dahlan. All rights reserved.

1. Introduction

Power converters are recently becoming interesting topics in power electronics and renewable energy research fields. The power converters are required to proceed and control the energy generated by the renewable energy sources to feed the power load with higher quality output power [1-4]. The power converters are also needed as link among energy sources and utility power grid operated together in order to obtain a more reliable power system. In spite of reliability, efficiency is another important issue in the design and application of power converters. Low efficiency of power converters will cause the total system efficiency become lower [5, 6].

In case of AC power system, the power load withdraw AC power from the energy sources. However, the renewable energy sources may generate either AC or DC power. For the AC power source, the voltage and frequency stability are the common problems such as the wind power system and micro/pico hydro electric power generations. Power converters of AC to AC are required to make the generated power stable. In the case of DC power source for instance photovoltaic system, fuel cell and battery system, DC to AC power converters are mandatory. This DC to AC power converter is well known as the power inverter, which is recently increase in the use, especially in the renewable energy system power generation [7-9].

In a power inverter, the frequency, magnitude, and phase angle values of AC voltage and current can be adjusted as required. Mainly, there are two categories of power inverters, i.e. voltage source power inverter and current source one [10-12]. The first type proceeds the DC input voltage become a certain AC voltage. The DC input bus uses capacitors to obtain a stable DC input voltage [13]. Hence, short circuit condition is prohibited in this type of inverter, as it will cause large current that could damage the inverter circuits. In the second inverter type, the power inverter proceeds the DC input current be a desired AC current. This inverter utilizes power inductor to generate a stable DC input current [14]. Different with the voltage source type inverter, in this inverter type an open circuit condition is forbidden, because a large voltage change will happen in the inductor that may destroy the circuits [15].

In order to obtain higher power of inverter circuits, a multilevel inverter has been introduced. This multilevel inverter generates a multistep AC output waveform from single or multi DC input power [16]. When the input is single or multi DC voltage sources and the output

is a multistep AC voltage, the power inverter is called as multilevel voltage source inverter. In contrast, when the DC input power is a single or multiple DC currents and the output waveform is a multistep AC current, the inverter is called as multilevel current source inverter circuits. Instead of higher power capability, a better output waveform can be produced using multilevel inverter circuits.

Figure 1 (a) presents circuit of a basic H-Bridge CSI. Its switching states to make three-level output current are presented in Table 1. Furthermore, Figure 1 (b) denotes another circuit of three-level inverter where the transistor switches, i.e. switch Q1, Q2, Q3 and Q4, are spliced at the common-emitter connection, whilst its switching states are indicated in Table 2 [17]. As can be observed in Table 1 and Table 2, both inverter circuits work generating three-level current waveforms, namely +I, 0 and -I level currents. In order to obtain higher power rating with higher quality of AC waveform, lower semiconductor devices rating, and low dv/dt or low di/dt, a multilevel inverter technology is a solution to achieve these goals.

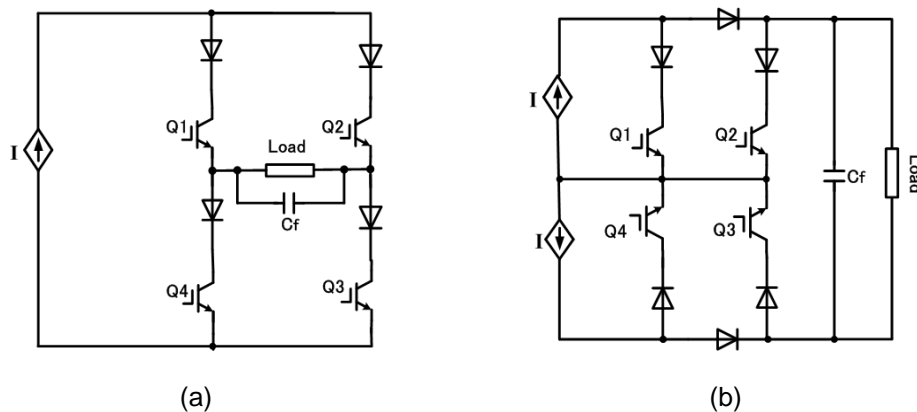

Figure 1. (a) Basic three-level H-bridge CSI, (b) Basic three-level common-emitter inverter [17]

Table 1. Operation of H-bridge CSI

Q ₁	Q ₂	Q ₃	Q ₄	I _{OUT}
ON	OFF	ON	OFF	+I
ON	OFF	OFF	ON	0
OFF	ON	OFF	ON	-I

Table 2. Operation of Three-level Common-emitter Inverter

Q ₁	Q ₂	Q ₃	Q ₄	I _{OUT}
OFF	OFF	ON	ON	+I
ON	OFF	OFF	ON	0
ON	ON	OFF	OFF	-I

Researchers have developed some circuits of MCSI to explore the merits of this inverter type. An easy approach to create a multistep current wave shape is by connecting two or more H-bridge or common-emitter inverters in parallel as denoted in Figure 2 (a) and 2 (b). Unfortunately, the large number controlled power semiconductor switches and splitted DC currents are some issues introduced in these inverter circuit configurations [17]. Large numbers of isolated DC currents add complexity of circuits. Another circuits of MCSI was developed by employing multi-cell circuits of MCSI or called as multi-rating inductor MCSI [18, 19]. The circuit structure is depicted in Figure 3 (a). Intermediate level balance of multistep AC current and its control is a main challenge of these circuits. Reference [20] discussed control strategies of the intermediate levels of multistep AC current. In these approaches, the inverter circuits still need bulky size of inductors, more than 100 mH.

Circuit of single rating inductor-cell MCSI was introduced dan discussed in reference [19]. The five-level inverter configuration of this inverter circuits is presented

in Figure 3 (b). To have intermediate levels of AC current waveform, the inverter circuits of multi-cell and single-rating inductor cell inverters take substantial size of intermediate inductors. Because of its large size, these inductors will increase the inverter's power losses. Moreover, they will occupy higher volume and add the weight of the power inverter. In practical, these are some issues appeared in these two inverter circuits.

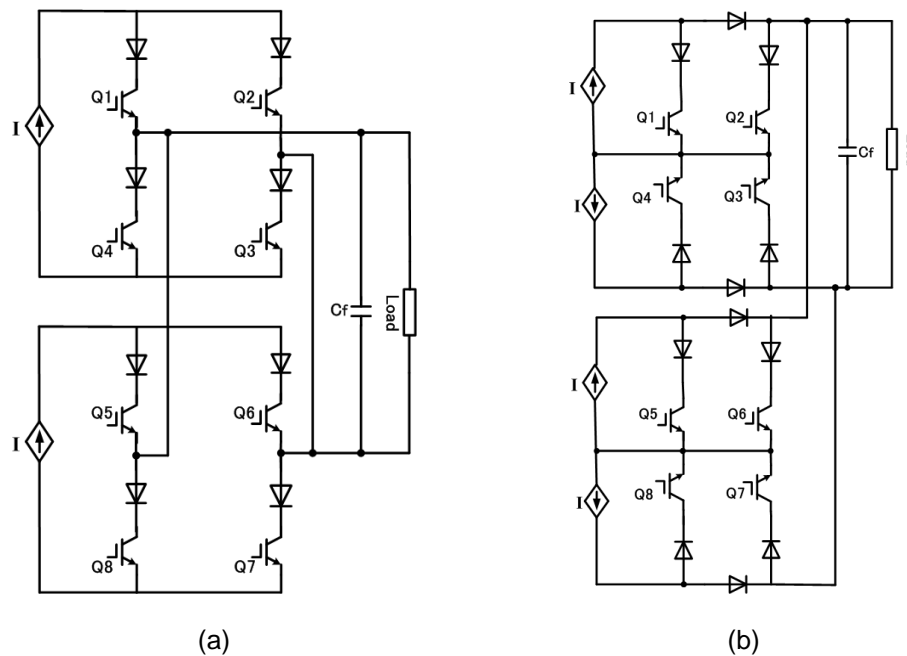

Figure 2. (a) Paralleled H-bridge MCSI, (b) paralleled common-emitter MCSI [17]

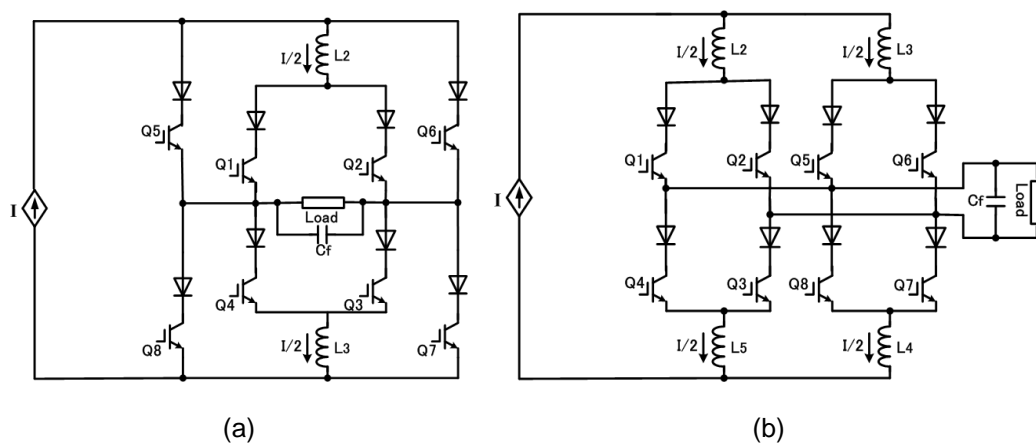

Figure 3. (a) Circuits of five-level multicell inverter [18],
(b) Circuits of five-level single-rating inductor cell inverter [19]

Reference [21] presented a topology of multilevel CSI which is a modified configuration of parallel H-bridge multilevel CSI as shown in Figure 4. However, even 400 mH bulky inductors have been used, large ripples of the smoothing inductor currents were still existing. These ripples will distort the output current waveform of the inverter. Moreover, the huge size of the inductors will increase the production cost of inverter, and it is troublesome in most of applications. Figure 5 (a) and 5 (b) represent a circuit structure of five-level H-bridge and common-emitter CSIs using inductor cell proposed in [10] and [22], respectively. Using effective current controller, the size of the intermediate inductor can be reduced in this topology.

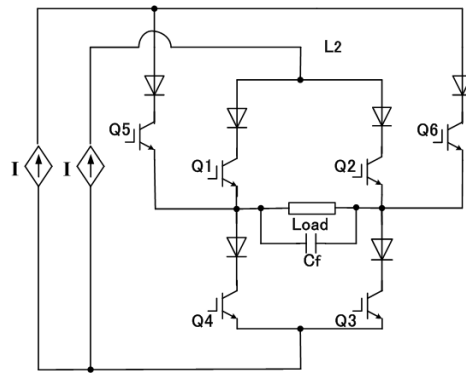
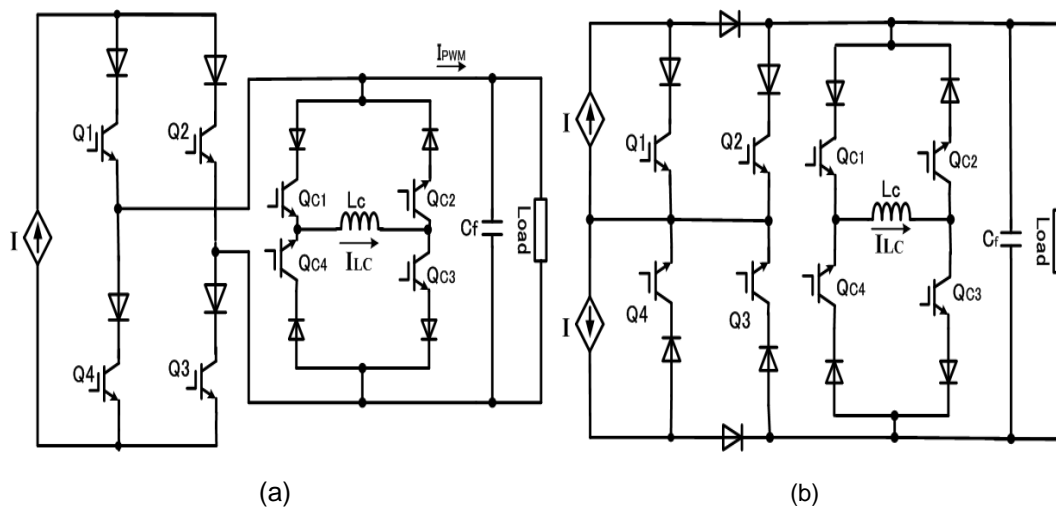

Figure 4. Five-level modified parallel H-bridge CSI [21]

Figure 5. (a) Five-level H-bridge CSI using inductor cell [10],
(b) Five-level CE CSI using inductor cell [22]

To the author's knowledge, there is no paper discussing the power loss analysis, especially for the MCSI circuits. As mentioned before, efficiency of power converters is an important factor in design and developing of power converters. This paper explored and discussed a power analysis of MCSI. Comparisons of some MCSI topologies are also presented.

2. Inverter Circuit Configurations

2.1. Multilevel H-bridge CSI using DC Current Modules

This part describes other circuit configuration of the MCSI developed from the basic H-bridge and common-emitter current source type inverters. Figure 6 describes the circuit of a DC current source module and its basic operation waveform. It consists of a single DC current, a single transistor switch and two diodes. This circuits are connected to the main three-level CSI to output AC current waveform with higher number of step. Figure 7 (a) is a generalized circuit configuration of multilevel CSI expanded from a three-level H-bridge inverter circuit and DC current modules. It is shown in figure, even more and more DC current modules are added to the H-bridge CSI, auxiliary switches of Q5, Q6 to Qn are still bounded at an emitter point with the switches Q3 and Q4 resulting in simpler gate drive circuits of converter. Figure 7 (b) is the circuit arrangement of five-level inverter constructed by a DC current module and an H-bridge CSI. The operation modes of this circuits are listed in Table 3. This circuit is able to deliver a five-level AC current waveform as shown in Table 3.

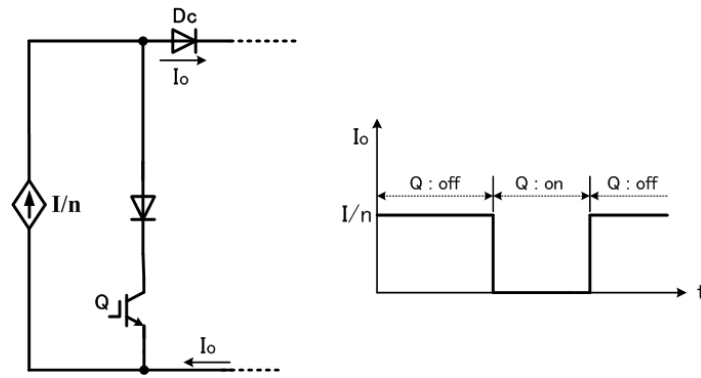

Figure 6. Proposed DC current module, and its typical output current waveform [23]

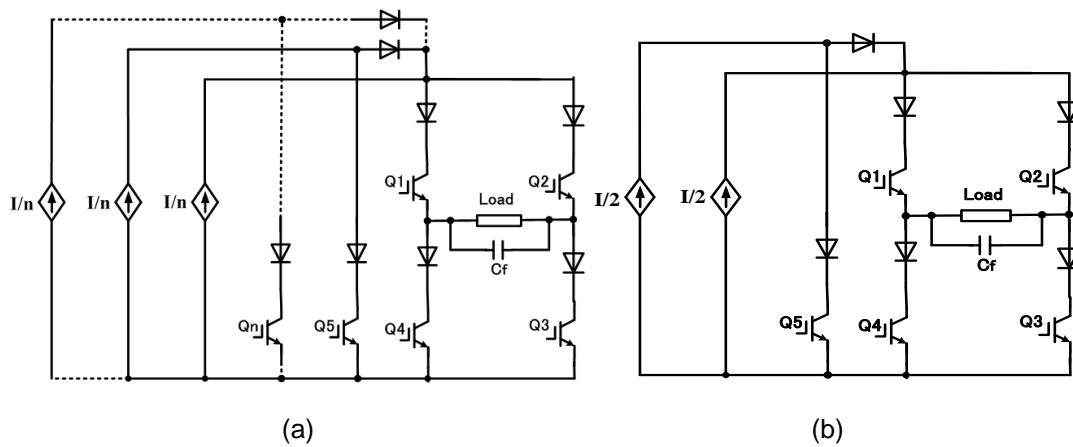

Figure 7. (a) Generalized configuration of H-bridge MCSI with DC current modules, (b) Five-level H-bridge with DC current modules [23].

Table 3. Operation of Five-level H-bridge Inverter using DC Current Modules

Q1	Q2	Q3	Q4	Q5	I_{OUT}
ON	OFF	ON	OFF	OFF	+1
ON	OFF	ON	OFF	ON	+1/2
ON	OFF	OFF	ON	ON	0
ON	ON	ON	OFF	ON	0
ON	ON	OFF	ON	ON	-1/2
ON	ON	OFF	ON	OFF	-1

2.2. Multilevel CECSI using DC Current Modules

Another configuration of MCSI can be generated using the basic three-level CECSI and the DC current modules. Figure 8 (a) presents the generalized circuit topology of multilevel CSI developed by using this technique. Two DC current modules and a single three-level CECSI are needed in the five-level inverter circuits as shown in Figure 8 (b). Operation modes of this inverter circuits are presented in Table 4. The great point of this topology is that even more and more DC current modules are connected with the three-level CECSI topology, all of the transistor switches and current sources are always tied at a common-emitter or at identical potential value. As a result the converter does not need isolated power supplies of the firing potential, nor separated DC current supplies and no potential change happen during the switching operation. Therefore, the converter is very compatible for very high speed switching application such for emerging high speed SiC based power switching devices [24].

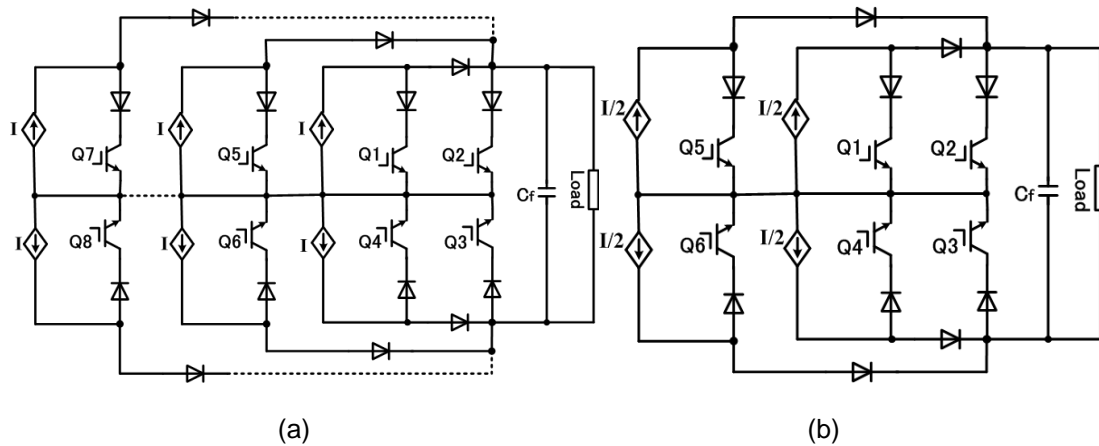

Figure 8. (a) Generalized topology of multilevel CECSI using DC current modules, (b) Circuit configuration of five-level CECSI [24]

Table 4. Operation Modes of Five-level CECSI

Q ₁	Q ₂	Q ₃	Q ₄	Q ₅	Q ₆	I _{OUT}
OFF	OFF	ON	ON	OFF	ON	+I
OFF	OFF	ON	ON	ON	ON	+I/2
ON	OFF	OFF	ON	ON	ON	0
ON	ON	OFF	OFF	ON	ON	-I
ON	ON	OFF	OFF	ON	OFF	-2I

Table 5 presents a comparison amongst some topologies of five-level CSI for the quantity of the controlled power switches, power diodes, power inductors and power supplies of driving circuits. As can be seen in the table, in the case of the controlled power switch and power diode number, the H-bridge with DC current modules type MLCSI need minimum number of power switches and power diodes. This circuits need five controlled switches and six power diodes only to yield a five-level current. However, in case of gate drive power supply number, the common-emitter with DC current module topology is the best circuits. It needs only a single power supply for driving circuits. This feature is the main feature of this circuit topology.

Table 5. Component Number Comparison of the Five-level CSIs

MLCSI Types	Controlled power switches	Power diodes	Inductor	Isolated gate drive power supply
Paralleled H-bridge	8	8	2	4
Paralleled Common-emitter	8	12	4	2
Multi-cell	8	8	3	4
Single rating inductor	8	8	5	4
H-bridge with inductor cell	8	8	2	4
CECSI with inductor cell	8	10	3	4
H-bridge with DC current modules	5	6	2	3
Common-emitter with DC current modules	6	10	2	1

2.3. DC Current Generator Circuits

In real current source inverter circuits, a DC current source generator circuit is required to create the DC currents as inputs of power inverter. The circuit is also work to control the DC current to obtain a stable DC current source [24]. In the MLCSI using H-bridge and common-emitter inverter with DC current modules, the DC current generator circuits are shown in Figures 9 (a) and 9 (b). A single DC current generator circuits composed by a single transistor switch, a diode and a power inductor as shown in these figures.

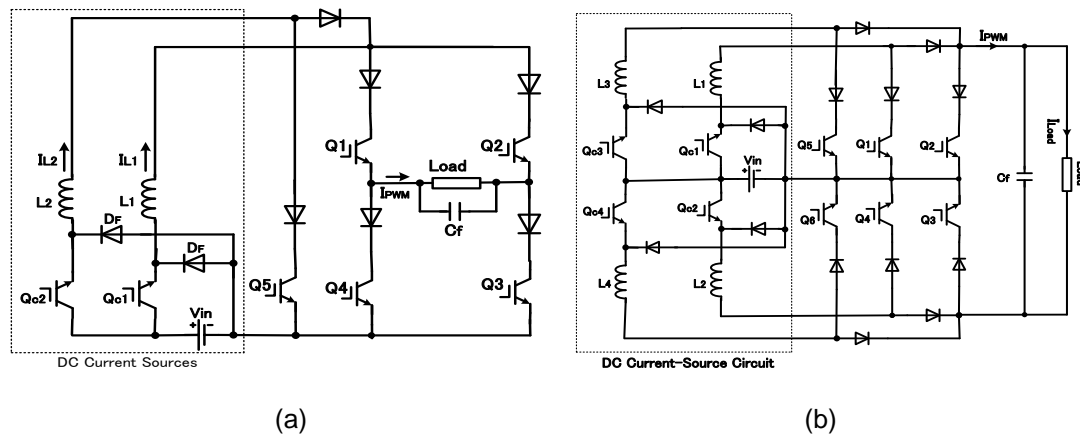

Figure 9. (a) Circuits of five-level H-bridge CSI applying DC current modules [23], (b) Five-level CECSI with DC current generator [24]

3. Power Loss Analysis of Multilevel CSIs

This section discusses the power losses analysis of multilevel CSIs. From author's literature search results, the inductor size used in the traditional MCSI topologies is very large, more than 100 mH. These bulky inductors will be the main cause of losses which will make efficiency of inverter circuits much lower than the multilevel VSI. In the topology of H-bridge CSI applying DC current modules, in case the magnitude of the M -level current inverter is denoted as I , and the sum of the current-module is N , amplitude of smoothing inductor current I_{LN} can be calculated as:

$$I_{LN} = \frac{I}{(N+1)} \tag{1}$$

in practical, copper winding used in power inductor has resistive component. Hence if the winding resistance is R_L , the conduction loss occurred in the smoothing inductor (P_{Lc}) caused by the current in (1) is:

$$P_{Lc} = \left(\frac{I}{N+1} \right)^2 R_L \tag{2}$$

Hence, the amount of conduction losses (P_{Lc-M}) generated by the smoothing inductors in a M -level current inverter circuit can be formulated as

$$P_{Lc-M} = (N+1) \left(\frac{I}{N+1} \right)^2 R_L = \frac{I^2 R_L}{N+1} \tag{3}$$

in the DC current modules based five-level inverter circuits, the magnitude of current flowing thru smoothing inductors is moiety of maximum magnitude of five-level current waveform. In a seven level inverter circuits, magnitude of smoothing inductor current is one third of maximum amplitude of seven-level current waveform, and so on as expressed in (1). Increasing the step number of current waveform will make the smoothing inductor current lowering. As a result, this condition is able to lower the total conduction losses caused by inductors in the inverter circuits. This property is one of benefits of this type of MCSI circuits.

In order to show the reduction of the inductor's conduction loss compared with other multilevel CSI topologies, an analysis comparison of inductor's conduction loss between the suggested five-level CSI, the five-level multi-cell CSI and the five-level single-rating inductor cell CSI is presented. It is assumed that all of five-level CSI topologies use an identical generator circuit for a DC current source generation.

Circuit structure of a five-level multi-cell CSI is presented in Figure 3 (a). In this topology, the smoothing inductor L_1 is employed for DC current generation circuit with current amplitude I . The inverter circuits use two intermediate inductors L_2 and L_3 , that are required to form transition level currents of five-level current waveform, i.e. $+I/2$ and $-I/2$ level currents. If the inverter outputs a five-level current with a maximum magnitude I , the current magnitude in the smoothing inductor L_1 is also I . However, the current magnitudes in intermediate inductors L_2 and L_3 will be same as $I/2$. Hence, if the resistances of the smoothing and the intermediate inductors are assumed the same as R_L , the conduction losses produced by the inductors of a five-level multi-cell CSI is expressed as

$$P_{Lc-5} = \frac{3}{2} I^2 R_L \quad (4)$$

the loss is three times higher than the conduction losses of inductors in the DC current modules based five-level current inverter, which is $P_{Lc-5} = (I^2 R_L)/2$, only.

In case of a five-level single-rating inductor cell CSI topology as depicted in Figure 3 (b), the inductors L_2, L_3, L_4 and L_5 are used to create the intermediate levels of the five-level current wave shape. In similar way, the conduction losses of inductors in a five-level single-rating inductor cell CSI can be calculated as

$$P_{Lc-5} = 2I^2 R_L \quad (5)$$

The inductor's conduction losses of a five-level single-rating inductor-cell CSI are four times higher than the inductor's conduction losses in a five-level current inverter using DC current modules. It shows that inductor's conduction losses can be reduced by using the proposed topology compared with the multi-cell and the single-rating inductor cell multilevel CSI topologies.

In order to show further reduction of inductor conduction losses, an analysis comparison of inductor conduction losses between the two topologies i.e. common-emitter with DC current modules and H-bridge with DC current modules are presented. The comparison of the inductor conduction losses for various output current levels of these topologies is shown in Figure 10, with some assumptions:

- 1) The size and copper resistance of all inductors are assumed the same as R_L
 - 2) All proposed topologies of multilevel CSI output the same amplitude current.
 - 3) The input DC currents are generated using circuits with smoothing inductors.
- As shown in this figure, the H-bridge with DC current modules can achieved lower inductor's conduction losses compared to the common-emitter with DC current modules.

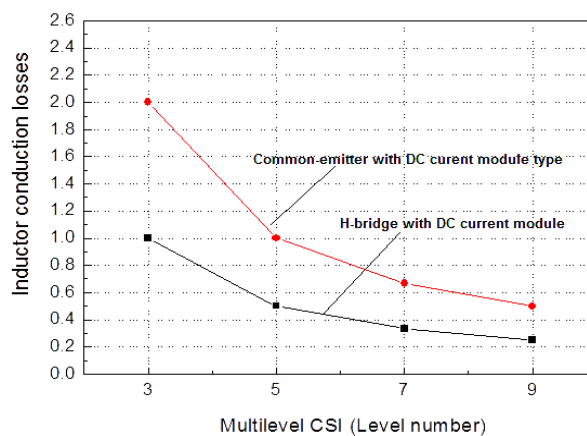

Figure 10. Inductor conduction loss comparison normalized to inductor conduction loss of the three-level inverter

Using DC current sources generation circuits with small smoothing inductors, i.e. 1 mH, the common-emitter with DC current modules, and H-bridge with DC current modules were tested. Figures 11 (a) and 11 (b) show the efficiency characteristic for both topologies. As can be observed in these figures, the higher the output current the higher the inverter's efficiency. Furthermore, by increasing the level amount of AC output current waveform, the total losses were also reduced.

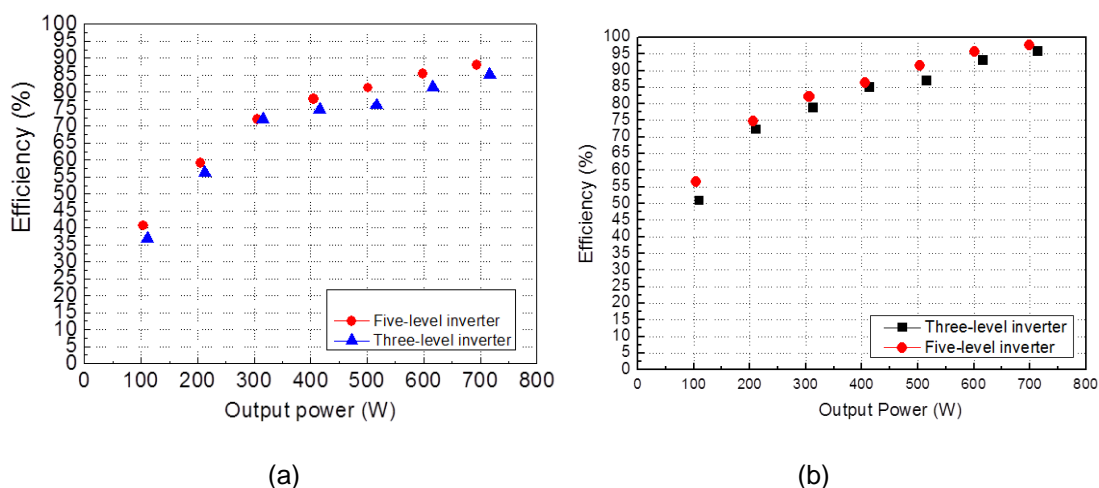

Figure 11. (a) Efficiency characteristics of DC current modules based CECSI multilevel CSIs, (b) Efficiency characteristics of DC current modules based H-bridge multilevel CSIs.

4. Conclusion

Efficiency of power converter is an important aspect that must be considered to achieve high efficiency of electrical power conversion. The paper presents a power loss analysis of the multilevel current source power inverters, i.e. the H-bridge CSI and common-emitter CSI using DC current modules. The analysis results showed that the H-bridge with DC current module type of MCSI has higher efficiency compared to the common-emitter with DC current modules. It also can be seen that the efficiency of MCSI can be improved by increasing the quantity of levels of the AC current waveform.

References

- [1] Suroso, Noguchi T. A Battery-less Grid Connected Photovoltaic Power generation using Five-Level Common-Emitter Current-Source Inverter. *International Journal of Power Electronics and Drive System*. 2014; 4(4): 474-480.
- [2] Barbosa P G, Braga H A C, Barbosa M C, Teixeria E C. Boost Current Multilevel Inverter and Its Application on Single Phase Grid Connected Photovoltaic System. *IEEE Transactions on Power Electronics*. 2006; 21(4): 1116-1124.
- [3] Suroso, Nugroho D T, Noguchi T. H-bridge based five-level current source inverter for grid connected photovoltaic power Conditioner. *TELKOMNIKA Telecommunication Computing and Control*. 2013; 11(3): 489-494.
- [4] Chen Y, Smedley K. Three-Phase Boost-Type Grid-Connected Inverters. *IEEE Transactions on Power Electronics*. 2008; 23(5): 791-797.
- [5] Suh Y, Steinke J K, Steimer P K. Efficiency Comparison of Voltage-Source and Current-Source Drive Systems for Medium-Voltage Applications. *IEEE Transactions on Industrial Electronics*. 2007; 54(5): 2521-2531.
- [6] Stupar A, Friedli T, Minibock J. Towards a 99% Efficient Three-Phase Buck-Type PFC Rectifier for 400-V DC Distribution Systems. *IEEE Transactions on Power Electronics*. 2012; 27(4): 1732-1744.
- [7] Rodriguez J, Lai J S, Peng F Z. Multilevel Inverter: A Survey of Topologies, Controls, and Application. *IEEE Transaction on Industrial Electronics*. 2002; 49(4): 724-738.

-
- [8] Suroso, Aziz A N, Noguchi T. Five-level PWM Inverter with a Single DC Power Source for DC-AC Power Conversion. *International Journal of Power Electronics and Drive Systems*. 2017; 8(3): 1230-1237.
- [9] Suroso, Noguchi T. A New Three-level Current-source PWM Inverter and Its Application for Grid Connected Power Conditioner. *Energy Conversion and Management*. 2010; 51(7): 1491-1499.
- [10] Suroso, Noguchi T. Multilevel Current Waveform Generation using Inductor Cells and H-bridge Current Source Inverter. *IEEE Transactions on Power Electronics*. 2012; 27(3): 1090-1098.
- [11] Suroso, Noguchi T. Five-Level Common-Emitter Inverter using Reverse-Blocking IGBTs. *TELKOMNIKA Telecommunication Computing and Control*. 2012; 10(2): 25-32.
- [12] Suroso, Noguchi T. A Single-Phase Multilevel Current-Source Converter using H-Bridge and DC Current Modules. *International Journal of Power Electronics and Drive System*. 2014; 2(4): 165-172.
- [13] Suroso, Aziz A N. *Voltage balancing circuits for five-level power inverter with a single DC voltage source*. 3rd International Conference on Information Technology, Computer, and Electrical Engineering (ICITACEE). Semarang. 2016. 147-150.
- [14] Bao J Y, Holmes D G, Bai Z H, Zhang Z C, Xu D H. *PWM control of a 5-level single-phase current-source inverter with controlled intermediate DC link current*. Proceedings of IEEE Power Electronics Specialist Conference. Jeju. 2006. 1633-1638.
- [15] Suroso, Nugroho D T, Winasis. *A three-level common-emitter current source inverter with reduced device count*. Proceedings of 4th International Conference on Information Technology, Computer, and Electrical Engineering (ICITACEE). Semarang. 2016. 77-80.
- [16] Kwak S, Toliyat H A. Multilevel Converter Topology Using Two Types of Current-Source Inverters. *IEEE Transactions on Industry Applications*. 2006; 42(6): 1558-1564.
- [17] Noguchi T, Suroso. *Review of novel multilevel current-source inverters with H-bridge and common-emitter based topologies*. Proceedings of IEEE Energy Conversion Congress and Exposition. Atlanta. 2010. 4006-4011.
- [18] Antunes F L M, Braga A C, Barbi I. Application of a Generalized Current Multilevel Cell to Current Source Inverters. *IEEE Transactions on Power Electronic*. 1999; 46(1): 31-38.
- [19] Bai Z H, Zhang Z C. Conformation of multilevel current source converter topologies using the duality principle. *IEEE Transactions on Power Electronic*. 2008; 23(5): 2260-2267.
- [20] McGrath B P, Holmes D G. Natural current Balancing of Multi-cell Current Source Inverter. *IEEE Transactions on Power Electronic*. 2008; 23(3): 1239-1246.
- [21] Vazquez N, Lopez H, Hernandez C, Vazquez E, Osorio R, Arau J. A different multilevel current source inverter. *IEEE Trans. on Industrial Electronics*. 2010; 57(8): 2623-2632.
- [22] Noguchi T, Suroso. New Multilevel Current-Source PWM Inverter with Full-Bridge Inductor Cells. *IEEE Transactions on Industry Applications*. 2010; 130(6): 808-815.
- [23] Suroso, Noguchi T. *New H-bridge multilevel current source PWM inverter with reduced switching device count*. Proceedings of The 2010 International Power Electronics Conference - ECCE ASIA. Sapporo. 2010. 1228-1235.
- [24] Suroso, Noguchi T. Common-Emitter Topology of Multilevel current-Source Pulse Width Modulation Inverter with Chopper based DC-Current Sources. *IET Power Electronics*. 2011; 4(7): 759-766.