

Design of a CMOS-based microwave active channelized bandpass filter

Jarjar Mariem*, Pr. El Ouazzani Nabih

Faculty of Sciences and Technology (FST),
Signals, Systems and Components Laboratory (LSSC), Fez-Morocco
*Corresponding author, e-mail: jarjarmariem@gmail.com

Abstract

A two-branch microwave active bandpass filter is designed through the channelized filtering technique as well as the transversal concept. Both the main and the auxiliary branches, connected without power dividers/combiners, rely on C-coupled active third order Chebyshev bandpass filters. A lumped element signal delay circuit is also introduced in the main channel. Active inductors based on the gyrator-C topology, are involved in the Chebyshev filters' structure. CMOS-based Operational Transconductor Amplifier (OTA) circuits are the building blocks of these inductors. The proposed active transversal channelized filter produces an elliptic narrow band response, centered at 1.13 GHz. Simulation results, obtained by means of the PSPICE code according to the 0.18 μm TSMC MOS technology, indicate excellent performances illustrating good impedance matching, low insertion losses and high selectivity. Finally, the noise analysis shows that the filter has a low noise figure in the bandwidth.

Keywords: active inductor, chebyshev filter, CMOS circuit, elliptic response, microwave active channelized filter, OTA

Copyright © 2019 Universitas Ahmad Dahlan. All rights reserved.

1. Introduction

Nowadays, the miniaturization of microwave filters remains a major constraint in the integrated circuits requirement. Active filtering technique contributes hugely towards this option, offering at the same time plenty of advantages such as high selectivity, low insertion losses. Yet, there are several problems to be overcome related to stability and complexity. As a result, microwave filter designers have come up with several configurations taking advantage of semiconductor properties and signal processing approaches. These topologies still raise concerns about stability and frequency bandwidth even though a great deal of improvement can easily be identified. Well known structures set up to compensate for passive element losses by means of either positive feedback or inserting negative resistance components are likely to lead to stability problems [1-5]. On the contrary, transversal active filters rely on feed-forward techniques and consequently provide circuits without stability and operating frequency range constraints [6, 7] but result in occupying considerable substrate area for narrow bandwidth applications.

As an alternative solution, the structure of channelized active filters can fulfil the above design conditions [8]. The main concept is based on directional signal channels that are connected in parallel with the aim of yielding filtering functions [9]. Delay elements, which create transmission zeros, are incorporated along with filters and amplifiers in the branches according to the transversal configuration [10]. In this paper, we develop a procedure of designing a two-branch microwave active transversal channelized filter having a narrow bandpass elliptic response. Both branches have identical Chebyshev bandpass active filters. Moreover, a discrete element delay circuit is also inserted into the filter in the main branch.

Both active Chebyshev filters are designed according to the well-known frequency transformation technique, with Operational Transconductor Amplifiers (OTA) as the building blocks leading to the C-coupled structure [11]. It consists in connecting, by means of capacitors, shunt LC resonators of which inductors are made of gyrator-C circuits involving OTA blocks [12]. The implementation of the whole concept employs the MOSFET transistor as a fundamental component taking advantage of its electric properties such as high input impedance, lower channel resistance and high speed functioning.

This paper is organized as follows. A general approach of channelized filters is presented in section 2. Section 3 deals with the design of a third order Chebyshev bandpass filter based on using grounded active inductors. Two-branch channelized bandpass filter is designed in section 4. Results related to the scattering parameters and noise are presented and discussed in section 5. Finally, the work is concluded in section 6.

2. Channelized Filters' Concept

This category of microwave filters being proposed in this paper handles the problem of miniaturization as well as the need for high quality performances such as bandwidth, losses and out-of-band rejection. Regarding to active filters, the essential point is to ensure stability of the circuit without compromising those performances in the operating frequency range [13]. The signal flow diagram of Figure 1 shows frequency-selective channels connected in parallel. The difference with previous transversal configurations comes mainly from the fact that the circuit branches are not only used for the aim of amplitude weighting but also as individual filtering elements. The presented topology enables to define the frequency response of each branch independently leading to any type of the resulting filter characteristics.

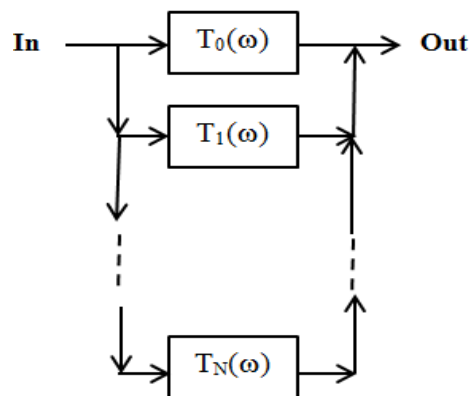

Figure 1. Channelized filter topology

Among the options available, the most interesting branches' filtering functions are bandpass responses, which can be specified according to the targeted overall performances. Besides the flexibility and the compactness, this design method contributes towards unconditional stability. A further important feature to be pointed out is the phasing aspect involving channel components. Thus, filter responses with sharp cut-offs can effectively be designed by means of creating transmission zeros. In order to achieve this task, a transversal-based configuration of channelized filters is obtained thanks to inserting delay elements into the independent branches which control the location of transmission zeros [14]. Figure 2 shows the general structure of an N-branch transversal channelized filter.

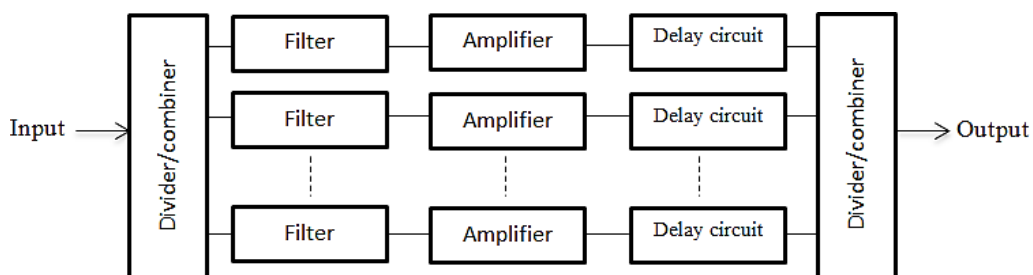

Figure 2. N-branch transversal channelized filter

Conventional design process of microwave channelized filters requires that each branch must have a passive bandpass filter, an amplifier for compensating losses, and a transmission line as a delay element. The power dividers/combiners connect all the branches at both the input and output of the whole filter. In this paper, we are interested in another option that relies on using active filters in the channels instead of separate passive filters and amplifiers, for more compactness and primarily better selectivity.

3. Chebyshev Active Bandpass Filter

3.1. Single Ended Active Inductor

Several active inductors' configurations have been proposed depending on integrated components as well as chosen topologies. CMOS-based inductors have been increasingly used in microwave circuits, particularly active filters [15]. Such elements occupy small areas, provide high quality factors (high-Q) and require low power consumption. The proposed grounded active inductor is designed according to the classical gyrator-C topology which is realized by associating OTA circuits in negative feedback whereas one port of the gyrator is connected to a capacitor.

Taking into account the advantages mentioned above, we have chosen to elaborate a CMOS-based OTA circuit in the 0.18 μm technology. Simple current mirrors are the most suitable for building the proposed OTA. As a result, the whole circuit involves a small number of MOS transistors which directly affects power consumption and noise performances. The current mirror consists of two PMOS transistors connected back to back with an NMOS differential pair. Figure 3 present the real structure of the proposed active inductor.

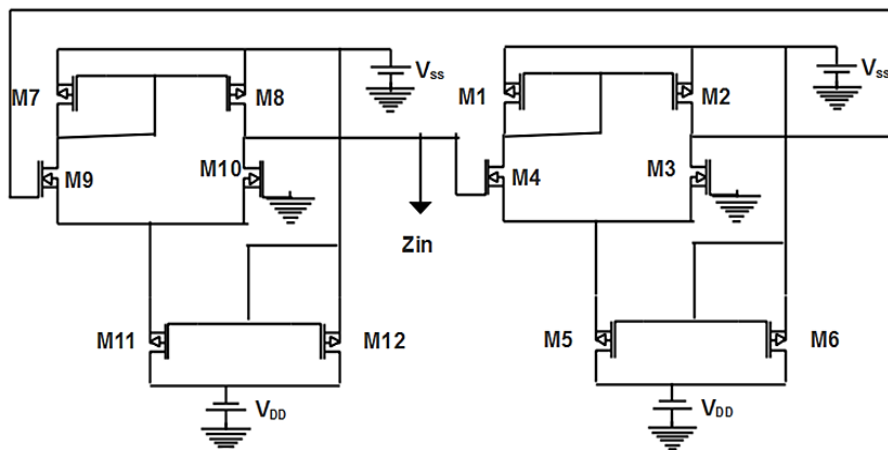

Figure 3. Circuit of the proposed grounded active inductor

Assuming that all the MOS transistors are similar, the input admittance of the active inductor is given by (1) on the basis of the small signal analysis [16]:

$$Y_{in} = \frac{I_{in}}{V_{in}} = G_m + \frac{G_m^2}{j\omega C_{GS} + G_{ds}} + j\omega C_{GS} \quad (1)$$

G_m stands for the OTA's transconductance, and C_{GS} and C_{DS} are the gate-source and the drain-source capacitors, respectively, where:

- $C_{GS} = 0.67$ nF
- $C_{DS} = 0.679$ nF
- $G_m = 35.01$ mS

C_{GS} stands for the capacitor C of the gyrator of Figure 3.

The quality factor and the resonance frequency can be derived from (1) and are expressed as follows:

$$Q = \frac{\text{IMG}(\frac{1}{Y_{in}})}{\text{REAL}(\frac{1}{Y_{in}})} \quad (2)$$

$$f_0 = \frac{1}{2\pi\sqrt{L_{eq}C_{gs}}} \quad (3)$$

where L_{eq} is the equivalent inductance of the circuit.

The simulation process is carried out, by means of the PSPICE code, taking into account the following electric and physical parameters:

$$V_{dd} = V_{SS} = 1.18 \text{ V}; \text{ Grid length} = 2 \text{ } \mu\text{m}; \text{ Grid Width} = 4 \text{ } \mu\text{m}$$

the obtained results are presented in Figure 4 from which we notice that the inductance value varies slightly around 47.8 pH whereas the circuit produces a good quality factor which is as high as 10000 at 1.13 GHz.

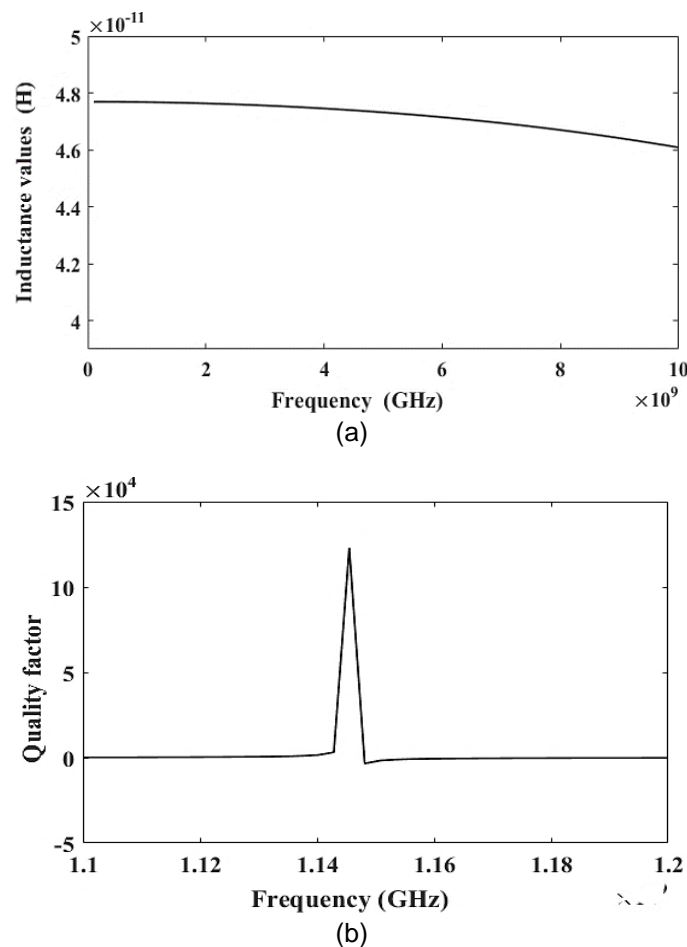

Figure 4. (a) Inductance value and (b) quality factor

3.2. Third order Chebyshev Bandpass Filter

The well-known prototype of the Chebyshev bandpass filters, based on connecting parallel and series LC resonators, has been chosen to synthesize the circuit of our interest according to the frequency transformation technique [17]. Several inductors can consequently be involved in such a topology resulting in high insertion losses. The use of admittance J-inverters helps reduce the number of inductors thanks to (4):

$$Y' = \frac{j^2}{Y_L} \quad (4)$$

the alternative configuration relies on (4) and can be built by incorporating J-inverters between shunt parallel LC resonators.

The design procedure is carried out according to the following steps. First, the center frequency f_0 and the bandwidth BW of the filter are defined. Second, the normalized parameters $g(i)$ are obtained from the Chebyshev prototype depending on the chosen order n . Finally, the algorithm made of (5)-(9) is applied for a predefined value of the inductance $L=L_{eq}$. As a result, different capacitors of the C-coupled structure are known.

$$J(1) = \sqrt{\frac{2\pi f_0 \times C_0 \times \Delta}{Z_0 \times 1 \times g(1)}} \quad (5)$$

$$J(n) = \sqrt{\frac{2\pi f_0 \times C_0 \times \Delta}{Z_0 \times g(n-1) \times g(n)}} \quad (6)$$

$$\text{for } 1 < i < n \quad j(i) = \frac{2\pi f_0 \times C_0 \times \Delta}{\sqrt{g(i-1) \times g(i)}} \quad (7)$$

$$C_{(n,n+1)} = \frac{j(n)}{2\pi f_0 \sqrt{(1 - (j(n) \times Z_0)^2)}} \quad (8)$$

$$C'_{(n)} = C_0 - C_{(n,n+1)} - C_{(n+1,n+2)} \quad (9)$$

where $\Delta = \frac{BW}{f_0}$; $C_0 = \frac{1}{(2\pi f_0)^2 L_{eq}}$, and $Z_0=50\Omega$.

Table 1 present the element values for maximally flat low-pass filter for 1-dB ripple Chebyshev prototype. As a result, the aim now is to build a third order 1-dB ripple Chebyshev active bandpass filter based on the previously proposed active inductor. The filter's response depends on the following parameters:

- Bandwidth BW=7MHz
- Center frequency $f_0=1.13$ GHz

The active inductor stands for the chosen value of 47.8 pH whereas the capacitors are determined by means of the previously described algorithm and given in Table 2 taking into account the topology of Figure 5. In order to illustrate the performances of the circuit, the bandpass filter has been designed according to the TSMC 0.18 μm CMOS process and then simulated by means of the PSPICE software. Figure 6 shows high quality responses in terms of the scattering parameters as well as the out-of-band rejection. Indeed, at the center frequency $f_0=1.13$ GHz the reflection coefficient S_{11} presents a value of -35dB and S_{21} equals 0 dB.

$g(1)$	$g(2)$	$g(3)$	$g(4)$
1.5963	1.0967	1.5963	1.0000

$C_{12}=C_{45}$	C_{23}	C_{34}	$C'_1=C'_3$	C'_2
11 pF	1.8 pF	1.8 pF	425pF	424 pF

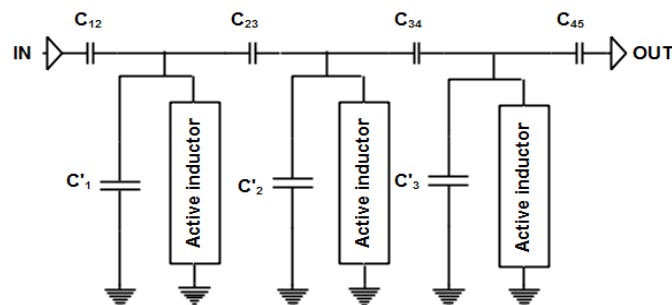
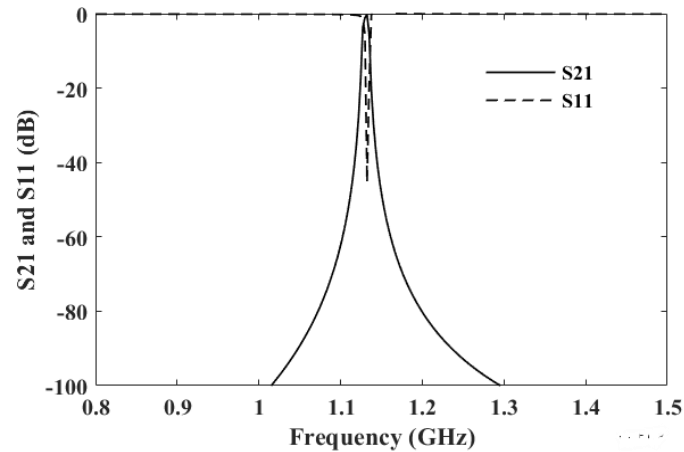

Figure 5. Final filter structure

Figure 6. S_{21} and S_{11} response

4. Two-branch Transversal Channelized Filter

4.1. Filter Topology

The two-branch filter can easily be derived from the previously described general concept [18, 19]. As a matter of fact, the implementation typically involves one main branch supported by an auxiliary channel without being connected through power dividers/combiners. The main branch is made of the association of the designed active Chebyshev filter and a signal delay circuit. Figure 7 shows the proposed two-branch channelized filter topology.

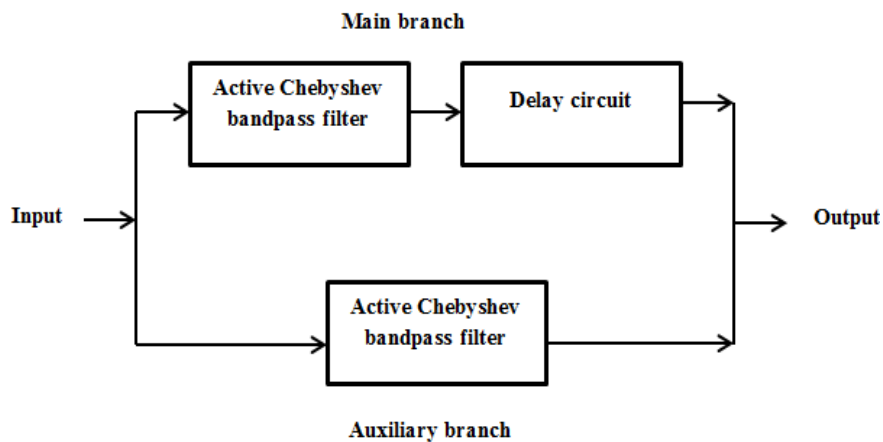

Figure 7. Proposed two branch transversal channelized active filter

4.2. Signal Delay Circuit

Transmission line segments can be implemented as delay sections providing, at a given frequency, a phase shift of 180° between the responses of the secondary and the main branches [20, 21]. Further research on transversal filters led to the use of lumped elements instead of transmission lines for optimization reasons as shown in Figure 8. The synthesis of such a circuit consists in connecting a low pass and a high pass filters whose cut-off frequencies are f_1 and f_2 , respectively. The corresponding cut-off frequencies are different so that we seek a linear phase variation with frequency over the interval $[f_1, f_2]$ where consequently the group delay is constant. Figure 9 shows the phase response and Table 3 presents the filter's elements values. The LC passive filter makes it possible to have a shift of 180° at its center frequency leading to a phase of a value of 0° .

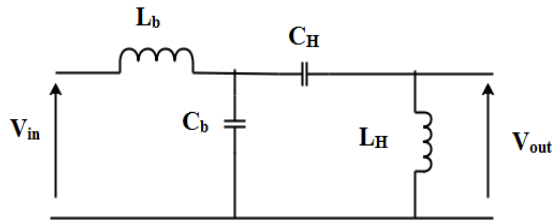

Figure 8. Delay circuit

Table 3. LC Bandpass Filter Components' Values

L_b	C_b	L_H	C_H
6.7nH	1.9pF	3.7pH	12.5nF

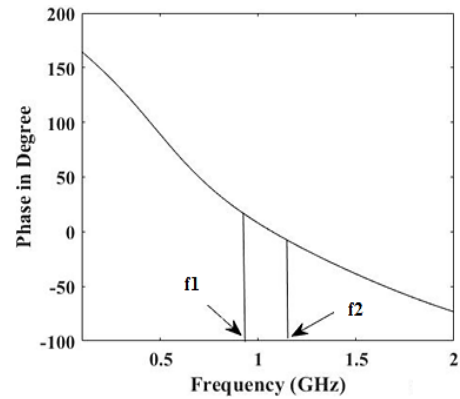

Figure 9. LC phase response

5. Results and Discussion

Once the proposed filter has been designed on the basis of the above method and taking into account the main objective, the simulation has been carried out, by means of the PSPICE software, under the same electric conditions as those of paragraph III. From Figure 10, we can easily notice that the transversal channelized filter produces an elliptic response demonstrating good out-of-band rejection thanks mainly to the delay element. The required matching at the input is obviously met as S_{11} is below -34 dB around the center frequency.

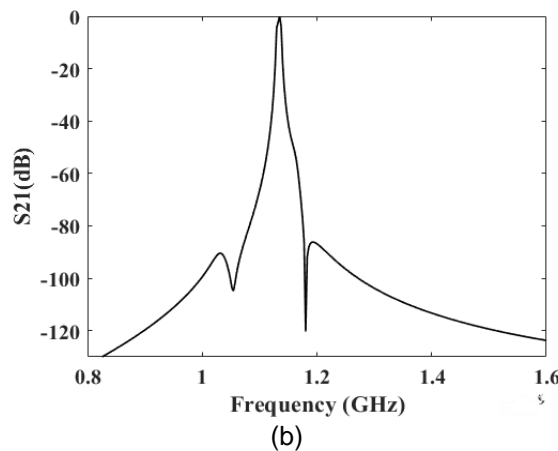
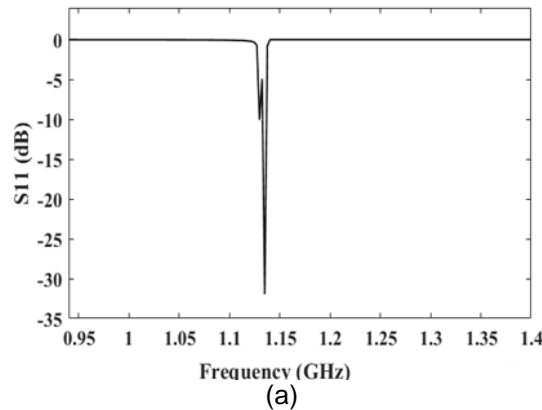

Figure 10. (a) S_{11} and (b) S_{21} response of channelized bandpass filter

For further investigation, a noise analysis is highly recommended regarding the noise figure parameter as active elements are involved in the topology. Figure 11 shows that the noise figure is below 4dB in the bandwidth, which is generally considered as a good performance. With regard to the most important performances, Table 4 shows a comparison between several results including the proposed ones. It is obvious that our contribution produce better values in terms of noise figure.

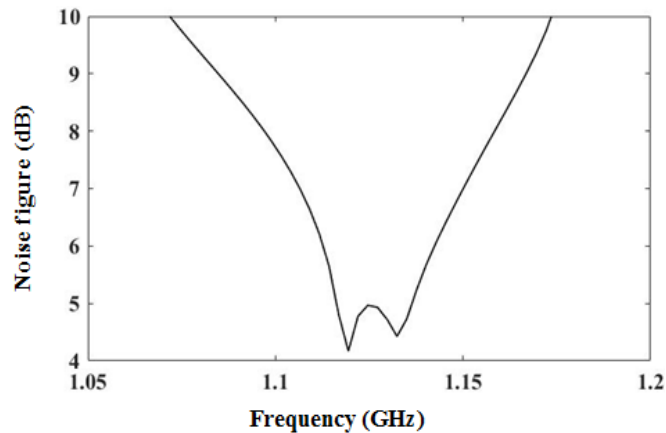

Figure 11. Noise figure

Table 4. Comparison of Channelized Bandpass Filter Performances

Ref	branches	f_0 (GHz)	Gain(dB)	NF(dB)
[22]	-	11.7	-7	18
[23]	3	2.5	7	-
[24]	2	2.5	15	4.5
[25]	2	0.852	0	-
This work	2	1.13	0	4

6. Conclusion

In this paper, a novel microwave active two-branch transversal channelized bandpass filter has been proposed. Both channels are connected without using power dividers/combiners. Throughout the design process, we have been limited to a topology involving one Chebyshev active bandpass filter in each branch. The 1-dB ripple Chebyshev filters are made of CMOS-based active inductors along with admittance inverters connected according to the C-Coupled structure. Simulation results, obtained by means of the PSPICE code, show excellent performances of the filter in terms of the scattering parameters and the noise figure. More importantly, the proposed channelized filter produces an elliptic response emphasizing the main advantage of the developed topology. In addition, the whole circuit has been subject to a noise analysis. The related noise figure values in the frequency band demonstrate the achievement of a low noise active filter which has been confirmed thanks to the comparison with other results.

References

- [1] Hopf BP, Wolff I, Guglielmi M. Coplana MMIC active bandpass filters using negative resistance circuits. *IEEE Transactions on Microwave Theory and Techniques*. 1994; 42(12): 2598–2602.
- [2] Cho YH, Hong SC, Kwon YS. A low-power monolithic GaAs FET bandpass filter based on negative resistance technique. *IEEE Microwave and Guided Wave Letters*. 1998; 8(4): 161–163.
- [3] Belfort D, Beilleau N, Aboushady H, Louerat MM. A Q-enhanced LC bandpass filter using CAIRO+. 16th IEEE International Conference on Electronics, Circuits, and Systems (ICECS). 2009: 860–863.
- [4] Hammadi AB, Mhiri M, Besbes K. A CMOS 0.35 μ m, 1.5 V Multi-band RF Q-enhanced LC Bandpass filter. *ICM*. 2011: 1–4.

- [5] Kuhn WB, Stephenson FW, Elshabini-Riad A. A 200 MHz CMOS Q-enhanced LC Bandpass Filter. *IEEE Journal of Solid-State Circuits*. 1996; 31(8): 1112-1122.
- [6] Jutzi W. Microwave bandwidth active transversal filter concept with MESFETs. *IEEE Trans. Microwave Theory Tech*. 1971; 19(9): 760-767.
- [7] Rauscher C. Microwave active filters based on transversal and recursive principles. *IEEE Transactions on Microwave Theory and Techniques*. 1985; 33(12): 1350-1360.
- [8] Rauscher C. Microwave channelized active filters-A new modular approach to achieving compactness and high selectivity. *IEEE Transactions on Microwave Theory and Techniques*. 1996; 44(1): 122-132.
- [9] Schindler MJ, Tajima Y. A novel MMIC active filter with lumped and transversal elements. *IEEE Trans. Microwave Theory Tech*. 1989; 37: 2148-2153.
- [10] Thibodeau E, Boone F. *Design of a Microwave Channelized Active Filter for MMIC*. Canadian Conference on Electrical and Computer Engineering. Saskatoon. 2005: 1543-1546.
- [11] Matthaei G, Jones E, Young L. *Microwave Filters, Impedance-Matching Networks, and Coupling Structures*. Norwood: Artech House. 1980.
- [12] Wu Y, Ding X, Ismail M, Olsson H. RF Bandpass Filter Design Based on CMOS Active Inductors. *IEEE Transactions on Circuits and Systems II: Analog and Digital Signal Processing*. 2003; 50(12): 942-949.
- [13] Gómez-García R, Briso-Rodríguez C, Mahfoudi M, Alonso JI. *MMIC tunable transversal bandpass active filter at 9-12 GHz*. Gallium Arsenide applications symposium. 2003: 149-152.
- [14] Darfeuille S, Sassi Z, Barelaud B, Billonnet L, Jarry B, Marie H, De La Torre A, Gamand P. *2-GHz 2.7-V Active Bandpass Filters on Silicon*. International Workshop on Microwave Filters. Toulouse. 2004.
- [15] Mariem JA, Nabih EO. Synthesis of a microwave CMOS active inductor using simple current mirror-based operational Transconductance Amplifier (OTA). *International Journal of Scientific & Engineering Research*. 2016; 7(8). ISSN 2229-5518.
- [16] Jarjar M, El Ouazzani N. *Design of an OTA-based microwave active bandpass filter*. 2017 International Conference on Wireless Technologies, Embedded and Intelligent Systems (WITS). 2017: 1-4.
- [17] Stošić BP, Dončov NS. Synthesis and Use of Wave Digital Networks of Admittance Inverters. *Microwave Review*. 2013; 19(2): 89-95.
- [18] Rauscher C. Two branch microwave channelized active bandpass filters. *IEEE Transactions on Microwave Theory and Techniques*. 2000; 48(3): 437-444.
- [19] Gómez-García R, Guyette AC. *Two-branch channelized passive filters for lowpass and bandpass applications*. Microwave Symposium (IMS), IEEE MTT-S International. 2016: 1-4.
- [20] Gomez-Garcia R, Loeches-Sanchez R, Psychogiou D, Peroulis D. Single/multiband Wilkinson-type power dividers with embedded transversal filtering sections and application to channelized filters. *IEEE Transactions on Circuits and Systems I: Regular Papers*. 2015; 62(6): 1518-1527.
- [21] Galy C, Graffeuil J, Larroque J, Vigneron S. *A Ku band MMIC transversal bandpass active filter*. 24th European Microwave Conference. Cannes. 1994; 2: 1048-1052.
- [22] Chen SW, Wu JW, Li JS. Tunable active bandpass filter design. *IEEE Electron. Lett*. 2011; 47(18): 1019-1021.
- [23] Gómez-García R, Briso-Rodríguez C, Mahfoudi M, Alonso JI. *MMIC tunable transversal bandpass active filter at 9-12 GHz*. 11th Gallium Arsenide Applications Symposium (GaAs 2003). Munich. 2003.
- [24] Gómez-García R, Alonso JI, Briso-Rodríguez C. On the design of high-linear and low-noise two-branch channelized active bandpass filters. *IEEE Transactions on Circuits and Systems II: Analog and Digital Signal Processing*. 2003; 50(10): 695-704.
- [25] Jachowski DR. *Passive enhancement of resonator Q in microwave notch filters*. IEEE MTT-S International Microwave Symposium Digest. 2004; 3: 1315-1318.