

## An electrical power control system for explorer-class remotely operated underwater vehicle (ROV)

Muhammad Ikhsan Sani\*, Simon Siregar, Muhammad Muchlis Kurnia, Dzikri Hasbialloh

Computer Engineering Department, Faculty of Applied Science, Telkom University, Indonesia

Jalan Telekomunikasi Terusan Buah Batu, Bandung 40257, West Java, Indonesia

\*Corresponding author, e-mail: m.ikhsan.sani@tass.telkomuniversity.ac.id

### Abstract

The importance of an optimal method for electric power transmission is crucial for ROV operation. Meanwhile, only few studies have shown the effect of electrical power system from power supply to ROV. This paper proposes a design and implementation of electrical power system for ROV that developed by Tech\_SAS team from Telkom University, Bandung, Indonesia. This work aims to obtain the optimal power system to supply ROV's electrical and electronic components. Tech\_SAS ROV is developed to compete on 1st and 2nd ASEAN MATE Underwater Robotic Competition. The system has demonstrated that 48V electric voltage can be transmitted to ROV with negligible voltage drop when using 20 meter 12AWG cable. The voltage is converted to 12V using DC-DC converter in order to supply various ROV's electronic devices ROV safely and efficiently. Meanwhile, the microcontroller was used to as thrust control to manage current flow to DC motor. The system has been evaluated and demonstrates optimal results and provides a design consideration about ROV's power system especially on tether cable and power distribution scheme.

**Keywords:** explorer-class, MATE, power system, ROV, tether cable, underwater robot

Copyright © 2019 Universitas Ahmad Dahlan. All rights reserved.

### 1. Introduction

The ASEAN MATE (Marine Advanced Technology Center) underwater robot competition since 2017 has been held in Indonesia as a qualification round for ASEAN region. The competition offers three different categories: Scout, Ranger and Explorer [1]. The Scout category has basic requirement for vehicle and usually entered by elementary school student. Ranger category is more advanced than Scout with additional electronic instrument and more difficult task. Meanwhile, the Explorer class has the most advanced vehicle specifications as it most likely used for real application. Tech\_SAS team have adopted Explorer category competition rule as the ROV is used for various task i.e. underwater wreckage salvation, water environment sensor installation, taking soil sample, installing or recovering a seismometer for monitoring tectonic plate activity and installing a renewable undersea tidal turbine or underwater construction maintenance.

Recent studies have uncovered the importance on power system as a heart of ROV operation. Various methods for transmitting electric power for underwater vehicle have developed i.e. contactless power supply system (CLPS) [2], Li-Ion battery packs [3], Nickel Metal-Hydride (NiMH) battery packs [4], semi-fuel cell [5], DMFC (Direct Methanol Fuel Cell) system [6], inductive power transfer [7], or photovoltaic cell/solar power [8, 9]. However, the mentioned papers address only battery-powered or contactless power transfer power system which are having limited energy capacity and charging range. Although there is an issue about tether-powered ROV disadvantage when accessing shallow waters, the power cable is still required to handle both electrical and mechanical functions [10-12].

Both electrical and electronic system inside ROV is running on DC power. AC voltage must be rectified and converted into appropriate DC voltage [13, 14]. Therefore, it is required to design a power distribution scheme and power transmission system to deliver a sufficient power to drive the thrusters and powering other electronic components [14, 15]. This paper presents an alternative method for transmitting power from power supply to ROV using AWG copper cable and controlled by PWM-based control system. This study was performed using Tech\_SAS, Explorer-class ROV that developed by Robotic-SAS team from Telkom University

for competing in 1<sup>st</sup> and 2<sup>nd</sup> ASEAN MATE Underwater Robotic Competition. The rest of this paper is organized as follows. Research method section describes a design and implementation of the power system in two main parts—ground system and underwater system. The discussion of system evaluation results is presented in Results and Discussion section. Last section shows the final remarks of conclusion.

## 2. Research Method

The proposed system block diagram is shown in Figure 1. The power system is divided into two main parts: ground system and underwater system. Tether cable is used as transmission medium from 48V power supply to ROV (underwater system). A 48V/40A Anderson-type fuse is installed for safety precaution. Three DC-DC converters are utilized for voltage step down converting. Two DC-DC converters are dedicated for supplying motor drivers and thrusters. Meanwhile, one DC-DC converter is used for supplying the rest of electronic components. An Arduino-based microcontroller is added for controlling motor thrust.

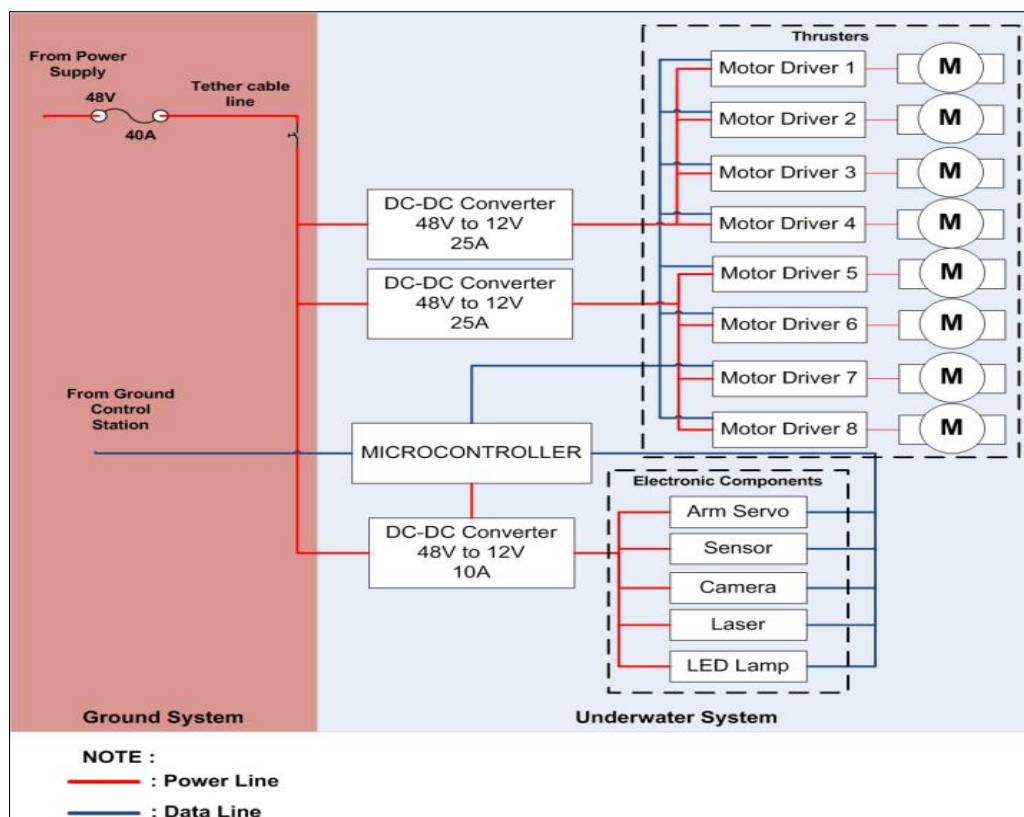

Figure 1. Proposed electrical power control system

### 2.1. Tether Cable Design

Tether cable play essential roles in ROV operation. Tether length dictates on how deep the ROV can be operated [10]. ROV power system is designed to support its ability to perform specific mission at maximum pool depth. For deep water application, work-class ROV is typically equipped by AC transmission line (1 or 3 phase) with 3–80 km long [16]. However, 1<sup>st</sup> and 2<sup>nd</sup> ASEAN MATE underwater competition held in pool venues with about 2.5 meter maximum depth, lower than international rule. According to 2018 Explorer class international rule, vehicle must be able operating in a maximum pool depth of 5.5 meters [1]. The tasks take place within 8 meters from the side of the pool. The ground control station is placed no more than 2 meters from the side of the pool. From this information, the tether cable minimum length

can be determine: 2 meters from ground control station to pool side added with 8 meters from pool edge to mission area plus 5.5 meters maximum pool depth and 4.5 meters extra cable length equals to 20 m. Meanwhile, Table 1 shows power distribution scheme that used on Tech\_SAS ROV. This table shows an estimated maximum current draw that ROV needs by calculating every components maximum load current. Tech\_SAS is equipped by six thrusters that each will draws 1.3 A at full power.

Table 1. Power Distribution Scheme.

Unit	Current (A)	Quantity	Current Consumption (A)
Thrusters	1.3	6	7.8
Electronic components (microcontroller, camera, sensor, laser, LED lamp, arm servo)	1	1	1
		TOTAL	8.8

This table also has shown that DC motors/thrusters draw most of power. Various magnet volume and torque usually give different results [17, 18]. For Tech\_SAS ROV, 12V/1.3A 1100 GPH bilge pump is chosen and modified into water-proofed DC motor as a thruster [19, 20]. The ROV minimum operating voltage should be at least 85% of the voltage delivered to the ROV. It means the maximum voltage drop should not exceed 1.8 volts. To calculate voltage drop, Ohm Law equation is used. From (3), the cable resistance for minimizing voltage drop is must be around 0.204 Ω or less.

$$V = I \cdot R \tag{1}$$

$$R = \frac{V}{I} \tag{2}$$

where  $V=1.8$  volts and  $I=8.8$  A

$$R = \frac{1.8}{8.8} = 0.204\Omega \tag{3}$$

Total tether cable resistance is calculated based on distance between power supply and load (ROV) back and forth. In this case, the distance is 20 meters times 2 is 40 meters Figure 2 shows tether cable between power supply and ROV. Table 2 provides conductor characteristic information using American Wire Gauge (AWG) standard value for typical copper wire.

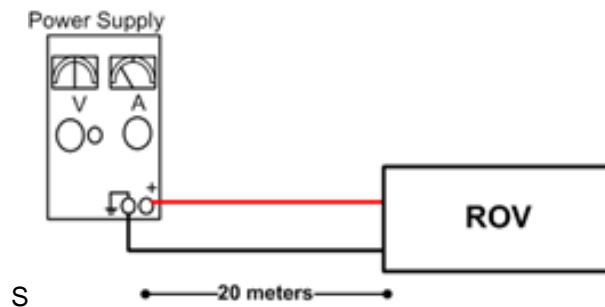

Figure 2. Tether cable length between power supply and ROV

Earlier we calculated that we needed a resistance of  $R=0.2$  ohms (or less). With this data and Table 2, it can be concluded that in terms of copper resistance and diameter (flexibility), 12AWG cable has the most optimal specification. 12AWG cable resistance is around 0.2 Ohm and its diameter 2.053 mm. The others are incompatible with this specification.

Table 2. Copper cable AWG Standard Specification Comparison [13, 21]

AWG Standard	Diameter (mm)	Copper Resistance (Ohm/m)	Tether cable resistance (20 m x 2) (Ohm)
1/0AWG	8.252	0.0003224	0.012896
4/0AWG	11.684	0.0001608	0.006432
12AWG	2.053	0.005211	0.20844
24AWG	0.511	0.08422	3.3688

## 2.2. Voltage Converter and Control System

Figure 3a shows different type of DC to DC Converters that used in Tech\_SAS ROV:

- Two DC-DC Converter 48V to 12V (25A) Step down Buck Converter–with safety fuse. Each converter is used to supply drive four thruster motors.
- One DC to DC 48V to 12V (20A) Step down Buck Converter-this one is used to supply the rest of electronic components such as microcontroller, camera, arm servo, LED lamp, and sensors.

Figure 3b shows ESC WP-1040 motor driver used on ROV to control the speed of a DC motor which is the thruster of ROV. Motor drivers specification is described as follow:

- Water-proof
- PWM controlled/Arduino compatible
- BEC: 5V/ 2A
- Can be powered using power supply equals to 2-3 Lipo, 5-9 NIMH



(a)



(b)

Figure 3. (a) DC-DC converter (b) WP-1040 motor driver

For controlling motor's thrust, a joystick with throttle lever for user interface. Throttle analog value is divided into nine level of thrust from 20 to 100%. Each thrust level is corresponded with PWM signal that sent to motor driver. The flow chart is shown in Figure 4.

The control software is programmed on both sides (ground and underwater system). The control program mechanism for ROV movement is described as follows:

- a. Throttle lever analog value is monitored continuously by microcontroller when in its stand-by mode.
- b. If there is an analog value change (up or down), the PWM signal will be sent to corresponding motor driver.
- c. The PWM signal is received by motor driver and controlling on how much power delivered to the DC motor thrusters.

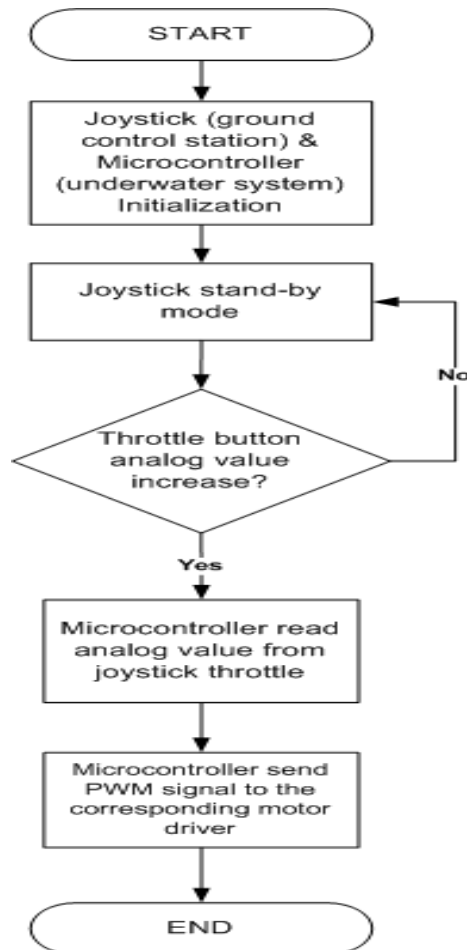

Figure 4. Thrust control system flowchart

### 3. Results and Analysis

#### 3.1. Tether Cable Voltage Drop Evaluation Results

After implementation, system is tested on 2.5 meter depth swimming pool. This test is conducted to evaluate the tether cable performance. The evaluation method involves 48V power supply and multimeter for measuring voltage at the end of tether cable. At minimum thrust scenario, all thrusters is set on 20% power. Voltage drop value is only about 0.11 V or 0.23% from total voltage. When the maximum thrust scenario is conducted, voltage drop value increased to 7.62 V. It means around 15.88%. This experiment results indicate that less than 85% voltage is delivered to the ROV. Nevertheless, there is no significant performance degradation with this condition. Table 3 summarized the results on this experiment.

Table 3. Tether Cable Voltage Drop

Thrust Percentage (%)	Voltage (V)	Voltage Drop (V)	Drop Percentage (%)
20	47.89	0.11	0.23%
100	40.38	7.62	15.88%

### 3.2. DC-DC Converter Line Regulation Evaluation Results

To measure the stability of the DC-DC converter, output voltage from several input voltage are evaluated. Figure 5 shows the experiment scenario block diagram. Two multimeter are used to observe input and output voltage simultaneously. A variable output power supply is utilized to simulate an unstable input voltage. The experiment is performed on full load condition. It means the ROV with its electrical and electronic components is connected to power supply. It is important to evaluate the loading effect using all components. 48V input is used as MATE competition states that the maximum voltage can be used for competition. At 48 V input, the output is always above 12V value with margin of error 0.1-0.5 V. Based on Table 4 the results indicate that the DC-DC converter output is relatively stable to the change of input voltage up to 39 volts. Figure 6 provided a numerical and visual evidence for its stability. The measured efficiency is above 85% because the output voltage only decreases by 0.01 volts in the load current above 1 A.

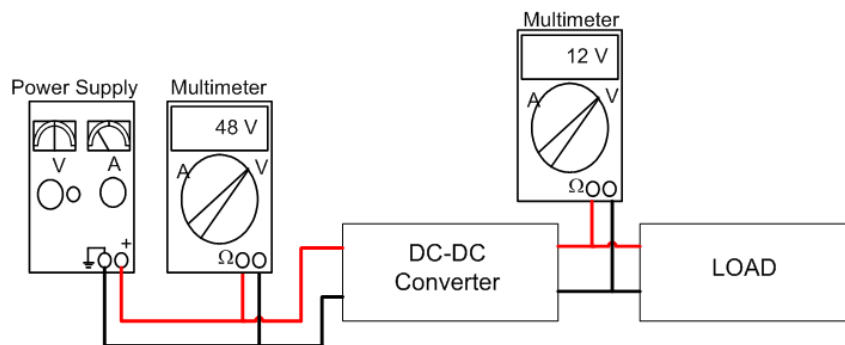

Figure 5. System evaluation block diagram

### 3.3. Thrust Control System Evaluation Results

This section presents the evaluation results of thrust control system. The experiment is started with minimum thrust scenario (20%). It should be noted that at less than 20% thrust, the motor is barely rotated. Hence, the results for thrust percentage below 20% are omitted. Table 5 shows that a relatively linear output with thrust input from 20-70% level. From Figure 7 a significant reverse interaction between thrust, voltage and current was intersected when the thrust value reach 70%. At this point, voltage is dropped and the current is approaching the driver maximum value.

Table 4. DC-DC Converter Line Regulation Results

No	Input (V)	Output-12V
1	48	12.50
2	47	12.48
3	46	12.48
4	45	12.47
5	44	12.46
6	43	12.45
7	42	12.41
8	41	12.01
9	40	11.89
10	39	10.05

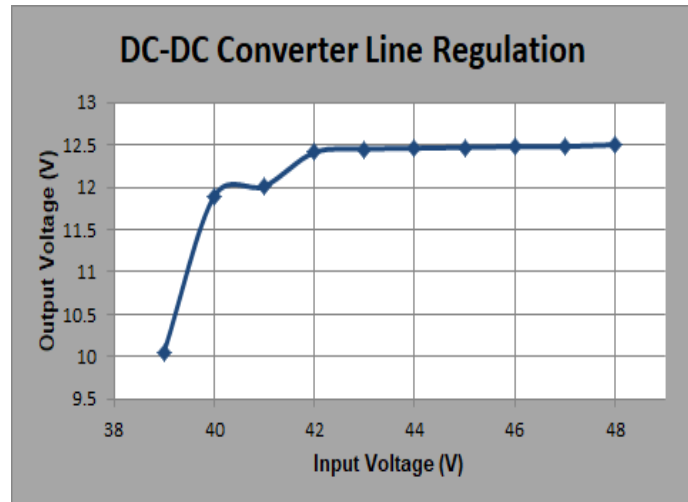

Figure 6. DC-DC converter input-output voltage

Table 5. Thrust Control System Evaluation Results

Thrust Percentage (%)	Voltage (V)	Current (A)
20	12.09	0.73
30	12.1	1.223
40	12.08	1.423
50	12.1	1.569
60	12.09	1.753
70	12.09	1.773
80	11.38	2.135
90	11.42	2.24
100	11.08	3.02

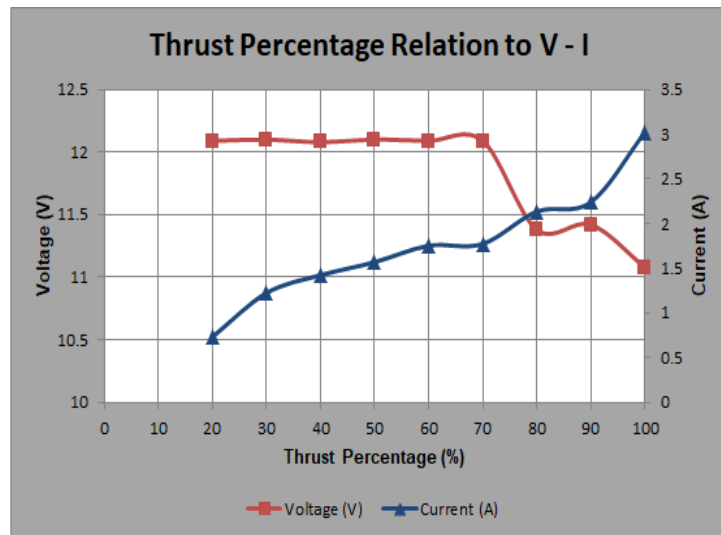

Figure 7. Relationship curve between thrust percentage and V-I

**4. Conclusion**

The work presented here demonstrates several points. The system has demonstrated that 48V electric voltage can be transmitted to ROV with negligible voltage drop when using 20 meter 12AWG cable. The effect of voltage drop on tether cable is proportional to the thrust level

applied. It is also related to power that can be transmitted. At worst case/maximum thrust scenario, voltage drop is reaching 15.88% without significant performance loss. It is common knowledge that the larger the diameter of the wire, the greater the power transferred but at cost of wire flexibility. It should be noted that Tech\_SAS ROV only use one pair 12AWG cable to obtain maximum flexibility.

The electric control system implementation on motor driver is able to manage relatively linear output voltage from 20-70% thrust level. Even at maximum thrust level (100%), the output voltage only drop to the 11.08 V. The system demonstrates optimal results and provides a design consideration about ROV's power system especially on tether cable and power distribution scheme. This research could be expanded to include an accurate voltage and current sensor to obtain power usage data from all electrical components as a feedback for operator. It should be noted that DC-DC converter output stability is required for ROV's operation [22]. A user-friendly graphical user interface should be developed to provide visual information for user [23]. Future works on this field also should be directed at different type of power supply and different type of cable [24, 25].

### Acknowledgment

This research was supported and funded by *Riset Desentralisasi-Penelitian Terapan Unggulan Perguruan Tinggi (PTUPT)* from Ministry of Research, Technology and Higher Education, Indonesia. This work was also supported by Embedded and Network System Research Laboratory and Robotic SAS team, Faculty of Applied Science, Telkom University.

### References

- [1] Marine Tech. 2018 MATE ROV Competition Manual : EXPLORER. 2018. 78.
- [2] Kojiya T, Sato F, Matsuki H, Sato T. *Automatic Power Supply System to Underwater Vehicles Utilizing Non-Contacting Technology*. Oceans '04 MTS/IEEE Techno-Ocean '04. 2004; 4: 2341–2345.
- [3] Bradley AM, Feezor MD, Singh H, Yates Sorrell F. Power Systems for Autonomous Underwater Vehicles. *IEEE J Ocean Eng*. 2001; 26(4): 526–38.
- [4] Brundage HM, Cooney L, Huo E, Lichter H, Oyebode O, Sinha P, et al. Design of an ROV to Compete in the 5th Annual MATE ROV Competition and Beyond. Ocean 2006. 2015.
- [5] Hasvold Ø, Størkersen NJ, Forseth S, Lian T. Power Sources for Autonomous Underwater Vehicles. *J Power Sources*. 2006; 162(2): 935–942.
- [6] Takagawa S. *Feasibility Study on DMFC Power Source for Underwater Vehicles*. 2007 Symposium on Underwater Technology and Workshop on Scientific Use of Submarine Cables and Related Technologies. 2007;(April):326–330.
- [7] Covic G a, Boys JT. Inductive Power Transfer. *Proc IEEE*. 2013; 101(6): 1276–89.
- [8] Mardiyanto R, Tamam B. Development of Water-Surface Robotic Vehicle to Assist Communication Between Remotely Operated Vehicle Underwater Robot and Control Station. 2017; 1(2): 13-18.
- [9] Arima M, Okashima T, Yamada T. *Development of a Solar-Powered Underwater Glider*. 2011 IEEE Symp Underw Technol UT'11 Work Sci Use Submar Cables Relat Technol SSC'11. 2011.
- [10] Azis FA, Aras MSM, Rashid MZA, Othman MN, Abdullah SS. Problem identification for Underwater Remotely Operated Vehicle (ROV): A case study. *Procedia Eng*. 2012; 41: 554–560.
- [11] Cook M, Crandle T, Cook G, Celkis E. Tradeoffs between Umbilical and Battery Power in ROV Performance. In: OCEANS 2017. Anchorage, USA: IEEE; 2017: 6.
- [12] Jordán MA, Bustamante JL. *Oscillation Control in Teleoperated Underwater Vehicles subject to Cable Perturbations*. In: 46th IEEE Conference on Decision and Control New. New Orleans: IEEE; 2007: 3561–6.
- [13] Christ RD, Wernli RL. The ROV Manual-A User Guide for Remotely Operated Vehicles The ROV Manual A User Guide for Remotely. 2nd ed. Elsevier. Elsevier; 2014. 679.
- [14] Capocci R, Dooly G, Omerdić E, Coleman J, Newe T, Toal D. Inspection-Class Remotely Operated Vehicles—A Review. *J Mar Sci Eng*. 2017; 5(1): 13.
- [15] Sharma G, Bezanson L, Poole M. Power Management of a 10-Thruster ROV Using an Auto-Configurable Algorithm. In: OCEANS 2015-MTS/IEEE Washington. Washington DC, USA: IEEE; 2015: 5.
- [16] Snary P, Bingham C, Stone D a. *Influence of ROV Umbilical on Power Quality when Supplying Electrical Loads*. In: 2005 European Conference on Power Electronics and Applications. Dresden, Germany: IEEE; 2005: 10.



- 
- [17] Ilka R, Gholamian SA. Optimum Design of a Five-phase Permanent Magnet Synchronous Motor for Underwater Vehicles by use of Particle Swarm Optimization. *TELKOMNIKA Telecommunication, Computing, Electronics and Control*. 2012; 10(4): 715–24.
- [18] Capocci R, Omerdic E, Dooly G, Toal D. Fault-Tolerant Control for ROVs Using Control Reallocation and Power Isolation. *J Mar Sci Eng*. 2018; 6(2): 40.
- [19] Chhabra P, Sehgal A. International Underwater Robotics Competition oriented Low-cost Light Weight Autonomous Underwater Vehicle Design. 2007.
- [20] Aras MSM, Abdullah SS, Azis F. Review on Auto-Depth Control System for an Unmanned Underwater Remotely Operated Vehicle (ROV) Using Intelligent Controller. *J Telecommun Electron Comput Eng*. 2015; 7(1): 47–55.
- [21] International Standard-IEC 60228. Third Edit, Conductors of Insulated Cables. Geneva, Switzerland; 2004.
- [22] Ibrahim O, Yahaya NZ, Saad N. State-space Modelling and Digital Controller Design for DC-DC Converter. *TELKOMNIKA Telecommunication Comput Electron Control*. 2016; 14(2): 497.
- [23] Harsamizadeh Tehrani N, Heidari M, Zakeri Y, Ghaisari J. *Development, Depth Control and Stability Analysis of an Underwater Remotely Operated Vehicle (ROV)*. In: 8th IEEE International Conference on Control and Automation. Xiamen, China: IEEE; 2010: 814–9.
- [24] Rivetta CH, Emadi A, Williamson GA, Jayabalan R, Fahimi B. Analysis and Control of a Buck DC-DC Converter Operating with Constant Power Load in Sea and Undersea Vehicles. *IEEE Trans Ind Appl*. 2006; 42(2): 559–72.
- [25] Nazem A, Arshad MR. *Frequency Modulated Power Supply Used to Navigate the Remotely Operated Vehicle (ROV)*. In: ICIAAS 2012-2012 4th International Conference on Intelligent and Advanced Systems: A Conference of World Engineering, Science and Technology Congress (ESTCON)-Conference Proceedings. 2012: 222–5.