

Circular polarization folded reflectarray antenna for 5G applications

Mohd Fairus Mohd Yusoff*, Lim Jit Min, Mohamad Rijal Hamid,
Zaharah Johari, Muhammad Naeem Iqbal

School of Electrical Engineering, Universiti Teknologi Malaysia, 81310 UTM Skudai, Johor, Malaysia

*Corresponding author, e-mail: fairus@fke.utm.my

Abstract

Fifth-generation (5G) is a wireless connection built specifically to keep up with the rapid increase of devices that need a mobile internet connection. A system working on 5G band can provide higher bandwidth and faster data rate as compared to fourth-generation (4G) band. Thus, an antenna with higher gain and lower profile is required to support this system. On the other hand, the performance of circular polarization antenna is better than linear polarization antenna due to its ability to accept wave from different direction. In this project, a low-profile circular polarization folded reflectarray antenna with operating frequency of 28 GHz is presented. This project is divided into two parts. In the first part, a linear polarization folded reflectarray antenna is designed. In this second part, a meander lines polarizer is used to convert the linear polarization antenna to circular polarization antenna. The antenna is fed by a linear polarized waveguide. Each radiating element of the antenna is in rectangular shape. The size of the radiating elements are selected according to obtain required phase delay to form a planar phase front in the far-field distance. Both of the antennas are simulated by using Computer Simulation Technology (CST) software. Finally, the results show excellent performances with 16.81 dB directivity and 1.49 dB axial ratio at 28 GHz. Thus, the antenna is very suitable for 5G applications.

Keywords: 5G wireless communication system, circular polarization, folded reflectarray antenna, meander lines polarizer

Copyright © 2019 Universitas Ahmad Dahlan. All rights reserved.

1. Introduction

Fifth-generation (5G) wireless communication is expected to release by year 2020. As compared to the current generation of wireless communication, 5G wireless communication has significant improvement in term of the system performances [1-3]. According to International Telecommunication Union (ITU), 5G wireless communication should be able to provide latency on millisecond level, traffic volume density of 10 Tbps/km², connection density of 1 million per square kilometer and so on [2-7]. Therefore, a suitable antenna with high gain, operating frequency and bandwidth is required in order to provide these services [8-13].

In this case, a circular polarization folded reflectarray antenna that can offer bigger bandwidth and higher gain compared to reflector and array antennas is proposed [12, 14-20]. The proposed antenna has reduced block effect and lower profile compared to reflectarray antenna. On the other hand, circular polarization antenna has some advantages over linear polarization antenna [21-24]. For instance, the circular polarization antenna is independent of the direction of wave and it has lower rain attenuation than linear polarization antenna.

2. Design of Folded Reflectarray Antenna

Figure 1 shows the configuration of a circular polarization folded reflectarray antenna. The antenna consists of four components, which are a primary source, a twist reflectarray reflector, a linear polarizing grid and a linear to circular polarizer. In this project, a meander lines polarizer is used to convert the antenna from linear polarization to circular polarization. Meander lines polarizer had been used in many antenna designs, thus its performance is guaranteed [25-32].

In general, a linear polarization incident wave propagates from the primary source to the linear polarizing grid. Only the wave with E-field perpendicular to the strips of the linear polarizing grid can pass through the grid, otherwise the wave reflects back to the twist

reflectarray reflector. The array elements on the twist reflectarray reflector twist the reflected wave by 90°. Then, the wave reflects from the reflector to the grid. The wave can pass through the grid now [17].

Table 1 shows the design specifications of the circular polarization folded reflectarray antenna. Copper was used to design the waveguide, while FR-4 was used to design linear polarizing grid, twist reflectarray reflector and meander lines polarizer. The dielectric constant of FR-4 is 4.3.

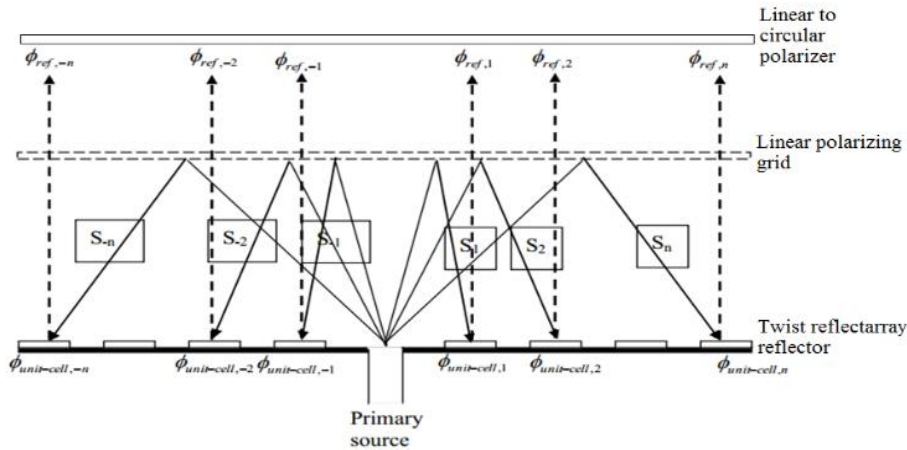

Figure 1. The configuration of a circular polarization folded reflectarray antenna

Table 1. Design Specification of Folded Reflectarray Antenna

Parameters	Specification
Operating frequency	28 GHz
Return loss	< -10 dB
Dimension of reflector	$5\lambda \times 5\lambda$
Feeding method	Rectangular waveguide
Array element	Rectangular patch with variable size
Array element spacing	0.455λ
Polarization	Circular
Circular polarizer	Meander lines polarizer

2.1. Primary Source

In this design, a rectangular open-ended waveguide WR-34 is used as shown in Figure 2. The simulation of open-ended waveguide was carried out by using CST software. Table 2 shows the technical specification of WR-34 waveguide.

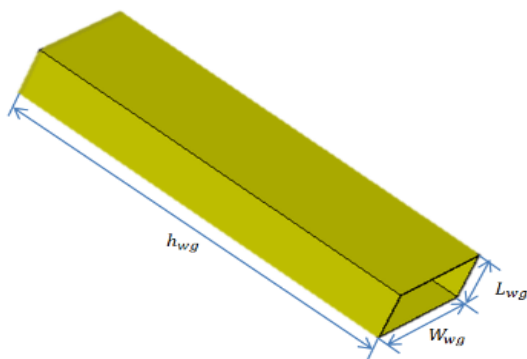

Table 2. Technical specification of WR-34 waveguide

Model	WR-34
Operating frequency	22-33 GHz
Length, L_{wg}	4.52 mm
Width, W_{wg}	8.84 mm
Height, h_{wg}	32.13 mm (3λ)
Material	Copper

Figure 2. WR-34 waveguide configuration

2.2. Linear Polarizing Grid

Table 3 shows the design specification of the linear polarizing grid. The total size of the linear polarizing grid is $5\lambda \times 5\lambda$. Figure 3 shows the front view and the side view of the linear polarizing grid.

Table 3. Design specification of linear polarizing grid

Characteristics	Dimensions
Length, L	53.55 mm (5λ)
Width, W	53.55 mm (5λ)
Substrate Height, h_2	0.30 mm
Patch Thickness, t	0.035 mm
Strip Width, W_{st}	0.17 mm
Strip Periodicity, P_{st}	0.40 mm
Material	FR-4 ($\epsilon_r = 4.3$)

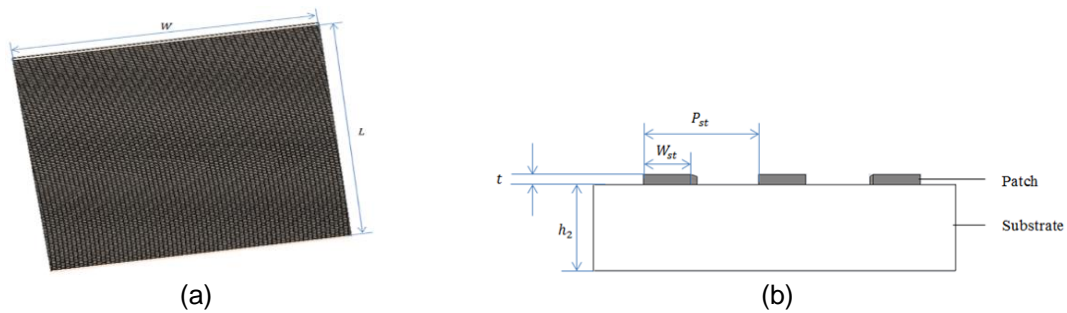

Figure 3. The (a) front view and the (b) side view of the linear polarizing grid

2.3. Twist Reflectarray Reflector

Table 4 shows the design specification of the twist reflectarray reflector. The total size of the reflector is $5\lambda \times 5\lambda$. Figure 4 shows the front view and the side view of the twist reflectarray reflector. The number of array element on the reflector is 11x11 elements.

Table 4. Design Specification of Linear Polarizing Grid

Characteristics	Dimensions
Length, L	53.55 mm (5λ)
Width, W	53.55 mm (5λ)
Substrate Height, h_1	0.30 mm
Patch Thickness, t	0.035 mm
Strip Width, W_{st}	0.17 mm
Strip Periodicity, P_{st}	0.40 mm
Material	FR-4 ($\epsilon_r = 4.3$)

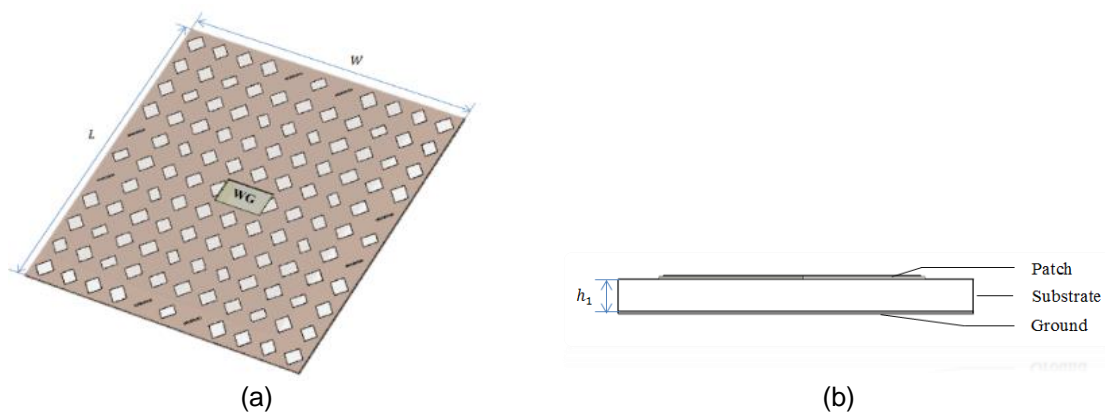

Figure 4. The (a) front view and the (b) side view of the twist reflectarray reflector

2.4. Meander Lines Polarizer

Table 5 and Table 6 show the design specifications and parameters of the meander lines polarizer respectively. The thickness of the substrate is 1.00 mm and the total size of the polarizer is $5\lambda \times 5\lambda$. Figure 5 shows the complete configuration of the meander lines polarizer. All the parameters were optimized using parametric study method. Figure 6 shows the front view and the side view of the meander lines polarizer.

Table 5. Design Specification of the Meander Lines Polarizer

Characteristics	Dimensions
Length, L	53.55 mm (5λ)
Width, W	53.55 mm (5λ)
Substrate Height, h_4	1 mm
Patch Thickness, t	0.035 mm

Table 6. Parameters of the Meander Lines Polarizer

Parameters	Dimensions
S_m	1.805 mm
P_m	1.805 mm
T_{m1}	0.105 mm
T_{m2}	0.065 mm
W_m	1.000 mm

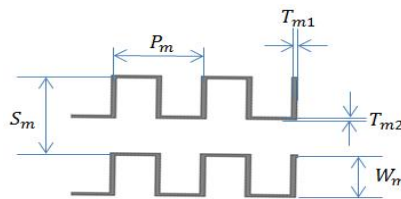

Figure 5. The configuration of the meander lines polarizer

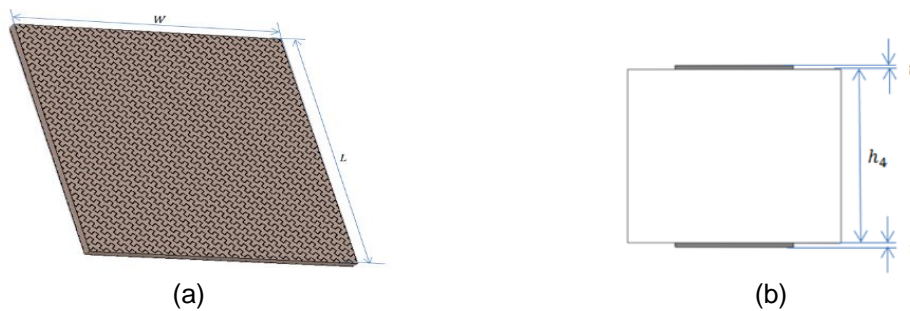

Figure 6. The (a) top view and the (b) side view of the meander lines polarizer

2.5. Circular Polarization Folded Reflectarray Antenna

All the components are combined together to form a circular polarization folded reflectarray antenna. Figure 7 shows the complete configuration of the circular polarization folded reflectarray antenna. The model was simulated using CST software.

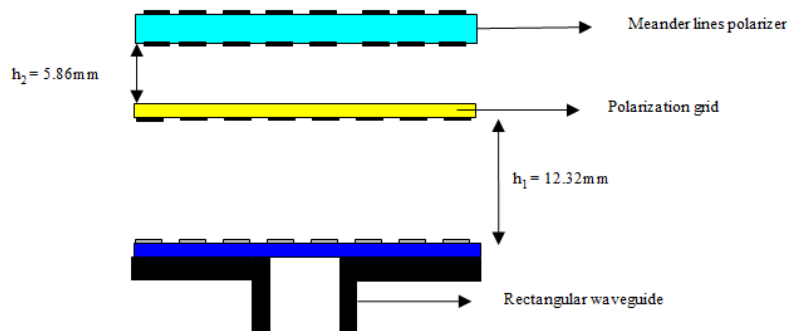

Figure 7. The circular polarization folded reflectarray antenna

3. Results and Discussion

Figure 8 illustrates a 3-dimensional graph to show the relationship between the reflection phase angle and the size of an array element. From the figure, the reflection phase angle of the array element is from -197.52° to 157.25° . The reflection phase angle range is 354.77° , which is practically enough for the design of the folded reflectarray antenna.

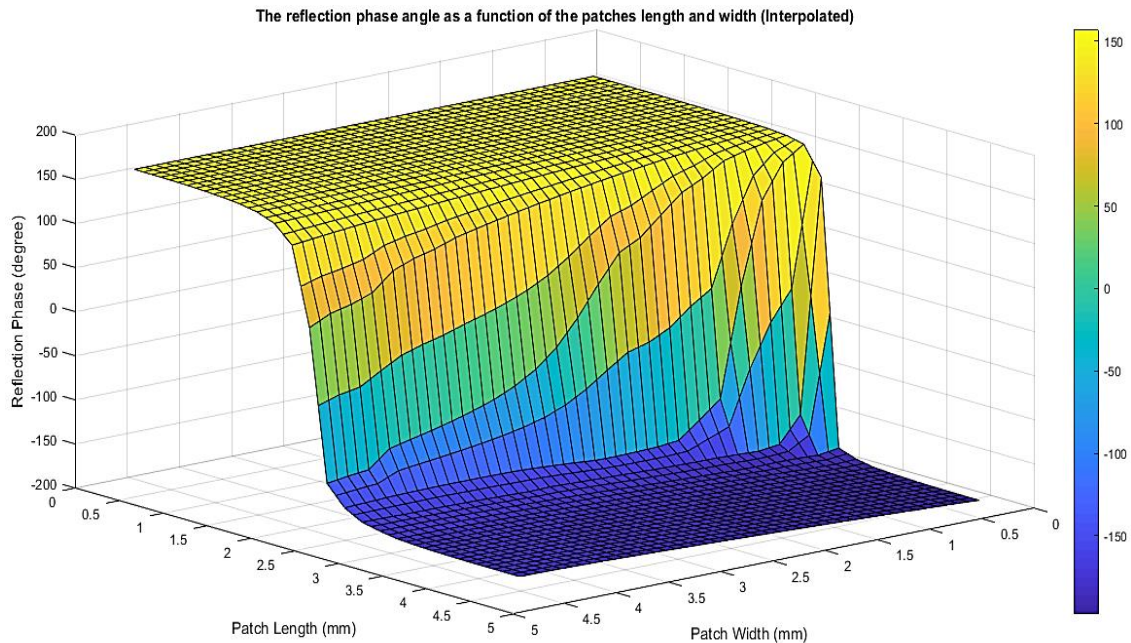

Figure 8. The reflection phase angle as a function of the patches length and width

Figure 9 shows the simulation result of the return loss of the circular polarization folded reflectarray antenna from 20 GHz to 36 GHz. From the graph, the circular polarization folded reflectarray antenna can operate from 26 GHz to 32.5 GHz. The bandwidth of this antenna is 6.5 GHz. Figure 10 shows the radiation pattern of the circular polarization folded reflectarray antenna in E-plane and H-plane. The directivity of the linear polarization folded reflectarray antenna is 19.4 dBi. From the graph, the direction of the main lobe of this antenna is at 0° . From Figure 10, the HPBW of the antenna in E-plane is 9.5° , while in H-plane is 11.7° . The radiation beam width of E-plane is more directive compared to H-plane. Other than that, the antenna has side lobe level of -12.4 dB in E-plane and -15.2 dB in H-plane. The circular polarization folded reflectarray antenna has excellent performances as the side lobe levels are below -10 dB in both E-plane and H-plane.

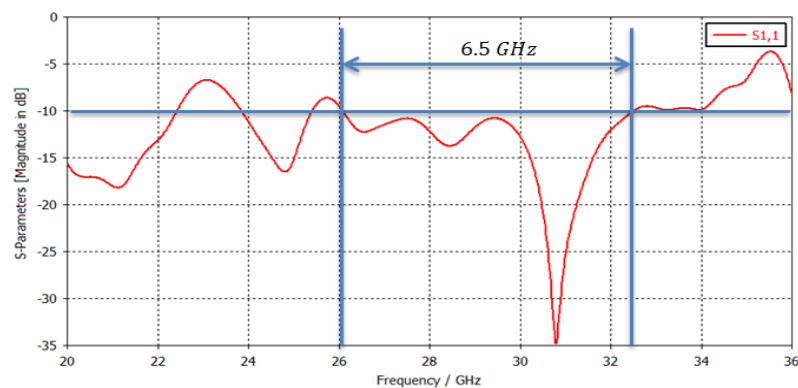

Figure 9. The return loss of the circular polarization folded reflectarray antenna

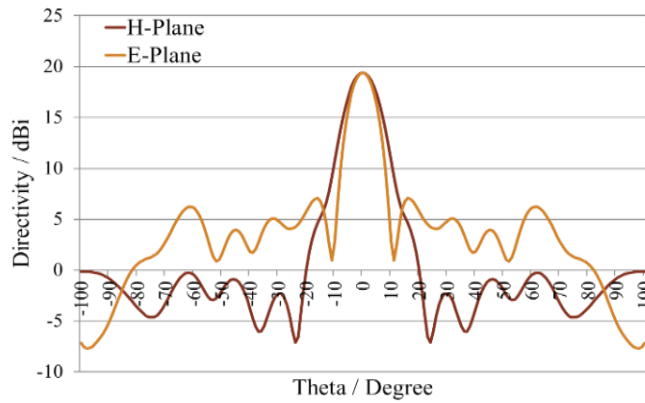

Figure 10. The radiation patterns of the circular polarization folded reflectarray antenna

Figure 11 shows the 3-dimension radiation pattern of the circular polarization folded reflectarray antenna at 28 GHz. The antenna achieves realized gain of 16.81 dB at 28 GHz. From section 4.2, the realized gain of the rectangular waveguide is 6.76 dB. Thus, the twist reflectarray reflector, the polarizing grid and the meander lines polarizer increase the gain of this antenna by 10.05 dB.

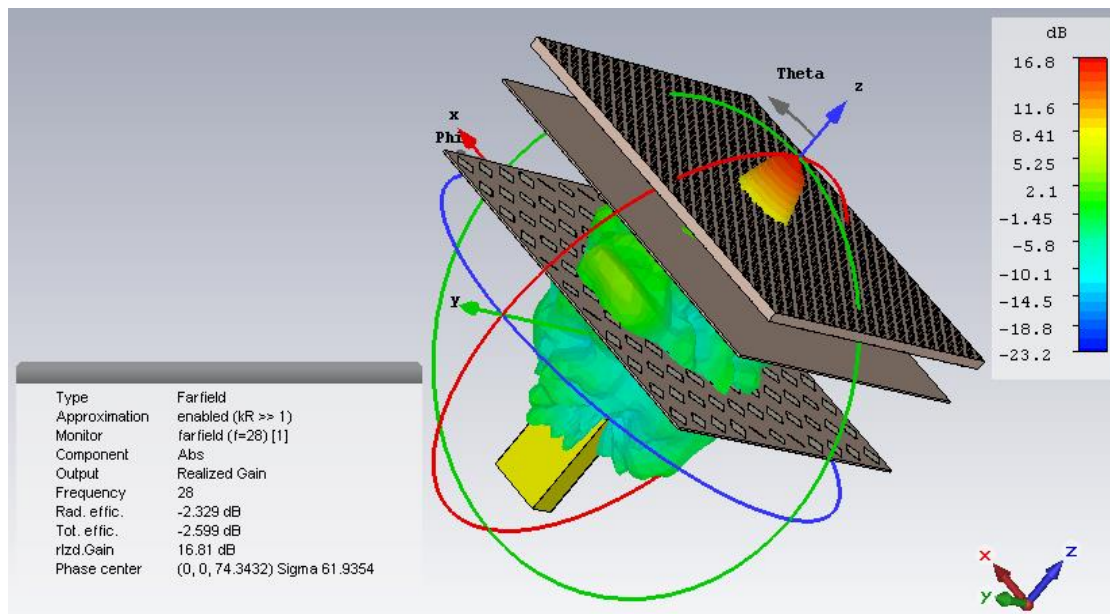

Figure 11. The 3-dimension radiation pattern of the circular polarization folded reflectarray antenna at 28 GHz

In order to make sure that the antenna is in circular polarization, the axial ratio of the antenna should be equal to or less than 3 dB. When $h=5.86$ mm, the axial ratio of the antenna at 28 GHz is 1.489 dB and the bandwidth of the antenna is 5.588 GHz. The antenna is in circular polarization when the frequency is in the range of 25.886 GHz to 31.474 GHz. Figure 12 shows the relationship between axial ratio of the antenna with theta at 28 GHz. From the graph, the circular polarization folded reflectarray antenna has 3 dB axial beam width of 26°.

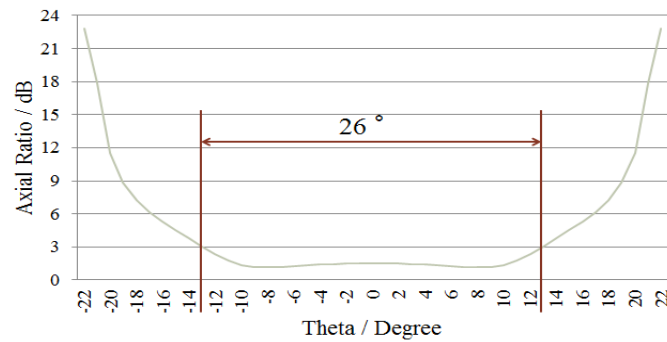

Figure 12. The axial ratio of circular polarization folded reflectarray antenna versus theta with $h=5.855$ mm

4. Conclusion

A circular polarization folded reflectarray antenna with operating frequency of 28 GHz was successfully designed and studied. The realized gain of the rectangular waveguide and the circular polarization folded reflectarray antenna are 6.76 dB and 16.81 dB respectively. The realized gain of the antenna is increased by 10.05 dB with present of a twist reflectarray reflector, a linear polarizing grid and a meander lines polarizer. For the circular polarization, the axial ratio is 1.489 dB at 28 GHz. This indicates that the antenna is in circular polarization at this frequency. In addition, the antenna shows excellent performance with side lobe level below -10 dB in both E-plane and H-plane. Therefore, the circular polarization folded reflectarray antenna is suitable for 5G applications.

Acknowledgements

The authors would like to thank the Ministry of Higher Education (MOHE), Research Management Centre (RMC), School of Electrical Engineering, Universiti Teknologi Malaysia (UTM) for supporting the research work, under grant no. 14J22.

References

- [1] Andrews JG, Buzzi S, Choi W, Hanly SV, Lozano A, Soong AC, et al. What will 5G be? *IEEE Journal on selected areas in communications*. 2014; 32: 1065-1082.
- [2] Wang C-X, Haider F, Gao X, You X-H, Yang Y, Yuan D, et al. Cellular architecture and key technologies for 5G wireless communication networks. *IEEE communications magazine*. 2014; 52: 122-130.
- [3] Yang N, Wang L, Geraci G, Elkashlan M, Yuan J, Di Renzo M. Safeguarding 5G wireless communication networks using physical layer security. *IEEE Communications Magazine*. 2015; 53: 20-27.
- [4] Demestichas P, Georgakopoulos A, Karvounas D, Tsagkaris K, Stavroulaki V, Lu J, et al. 5G on the horizon: Key challenges for the radio-access network. *IEEE vehicular technology magazine*. 2013; 8: 47-53.
- [5] Rappaport TS, Sun S, Mayzus R, Zhao H, Azar Y, Wang K, et al. Millimeter wave mobile communications for 5G cellular: It will work! *IEEE access*. 2013; 1: 335-349.
- [6] Chen S, Zhao J. The requirements, challenges, and technologies for 5G of terrestrial mobile telecommunication. *IEEE communications magazine*. 2014; 52: 36-43.
- [7] Roh W, Seol JY, Park J, Lee B, Lee J, Kim Y, et al. Millimeter-wave beamforming as an enabling technology for 5G cellular communications: Theoretical feasibility and prototype results. *IEEE communications magazine*. 2014; 52: 106-113.
- [8] Hong W, Baek K-H, Lee Y, Kim Y, Ko S-T. Study and prototyping of practically large-scale mmWave antenna systems for 5G cellular devices. *IEEE Communications Magazine*. 2014; 52: 63-69.
- [9] Han S, Chih-Lin I, Xu Z, Rowell C. Large-scale antenna systems with hybrid analog and digital beamforming for millimeter wave 5G. *IEEE Communications Magazine*. 2015; 53: 186-94.
- [10] Ojaroudiparchin N, Shen M, Fr G. *Multi-layer 5G mobile phone antenna for multi-user MIMO communications*. 2015 23rd Telecommunications Forum Telfor (TELFOR): IEEE. 2015: 559-62.
- [11] Ban Y-L, Li C, Wu G, Wong K-L. 4G/5G multiple antennas for future multi-mode smartphone applications. *IEEE access*. 2016; 4: 2981-2988.

- [12] Shen Y, Hu S, Dou W. 38 GHz folded reflectarray antenna for point-to-point 5G communications. 2016 IEEE 5th Asia-Pacific Conference on Antennas and Propagation (APCAP): IEEE. 2016: 369-70.
- [13] Hong W, Jiang ZH, Yu C, Zhou J, Chen P, Yu Z, et al. Multibeam antenna technologies for 5G wireless communications. *IEEE Transactions on Antennas and Propagation*. 2017; 65: 6231-6249.
- [14] Pilz D, Menzel W. Folded reflectarray antenna. *Electronics Letters*. 1998; 34: 832-833.
- [15] Menzel W, Pilz D, Al-Tikriti M. Millimeter-wave folded reflector antennas with high gain, low loss, and low profile. *IEEE Antennas and Propagation magazine*. 2002; 44: 24-29.
- [16] Zornoza JA, Leberer R, Encinar JA, Menzel W. Folded multilayer microstrip reflectarray with shaped pattern. *IEEE Transactions on Antennas and Propagation*. 2006; 54: 510-518.
- [17] Yusoff MFM, Sauleau R, Hamid MR, Rahim M, Yusoff M. *Beam scanning folded reflectarray antenna with shifted waveguide positions*. 2013 IEEE International RF and Microwave Conference (RFM): IEEE. 2013: 193-196.
- [18] Jiang M, Hong W, Zhang Y, Yu S, Zhou H. A folded reflectarray antenna with a planar SIW slot array antenna as the primary source. *IEEE Transactions on Antennas and Propagation*. 2014; 62: 3575-83.
- [19] Liu X, Ge Y, Chen X, Chen L. Design of folded reflectarray antennas using pancharatnam-berry phase reflectors. *IEEE Access*. 2018; 6: 28818-28824.
- [20] Yang J, Shen Y, Wang L, Meng H, Dou W, Hu S. 2-D scannable 40-GHz folded reflectarray fed by SIW slot antenna in single-layered PCB. *IEEE Transactions on Microwave Theory and Techniques*. 2018; 66: 3129-3135.
- [21] Pett TA, Olson SC, Sreenivas AI. Broadband circular polarization antenna. Google Patents. 1995.
- [22] Yang F, Rahmat-Samii Y. A reconfigurable patch antenna using switchable slots for circular polarization diversity. *IEEE Microwave and Wireless Components Letters*. 2002; 12: 96-98.
- [23] Toh BY, Cahill R, Fusco VF. Understanding and measuring circular polarization. *IEEE Transactions on Education*. 2003; 46: 313-318.
- [24] Wu F, Luk KM. Circular Polarization and Reconfigurability of Fabry-Perot Resonator Antenna through Metamaterial-Loaded Cavity. *IEEE Transactions on Antennas and Propagation*. 2019.
- [25] Young L, Robinson L, Hacking C. Meander-line polarizer. *IEEE Transactions on Antennas and Propagation*. 1973; 21: 376-378.
- [26] Chu R-S, Lee K-M. Analytical method of a multilayered meander-line polarizer plate with normal and oblique plane-wave incidence. *IEEE Transactions on Antennas and Propagation*. 1987; 35: 652-661.
- [27] Wu T-K. Meander-line polarizer for arbitrary rotation of linear polarization. *IEEE microwave and guided wave letters*. 1994; 4: 199-201.
- [28] Mazur M, Zieniutycz W. *Multi-layer meander line polarizer for Ku band*. 13th International Conference on Microwaves, Radar and Wireless Communications MIKON-2000 Conference Proceedings (IEEE Cat No 00EX428): IEEE. 2000: 78-81.
- [29] Joyal M-A, Riel M, Demers Y, Laurin J-J. A meander-line circular polarizer optimized for oblique incidence. *IEEE Transactions on Antennas and Propagation*. 2015; 63: 5391-5398.
- [30] Stankovsky A, Polenga S, Nemshon A, Litinskaya Y, Gafarov E, Salomatov YP. *Meander-line polarizer for omnidirectional antenna*. 2016 International Siberian Conference on Control and Communications (SIBCON): IEEE. 2016: 1-4.
- [31] Fei P, Guo W, Wen X. A Low Profile Meander Line Circular Polarizer for Wideband Applications. 2018 *International Conference on Microwave and Millimeter Wave Technology (ICMMT)*: IEEE. 2018: 1-3.
- [32] Nakajima H, Tanaka T, Takikawa M, Yoneda N. *A Study of Meander Line Polarizer Based on Equivalent Circuits*. 2018 IEEE International Workshop on Electromagnetics: Applications and Student Innovation Competition (IWEM): IEEE. 2018.