

Evolution of millimeter-wave communications toward next generation in wireless technologies

A. Z. Yonis

Communication Engineering Department, College of Electronics Engineering,
Ninevah University, Mosul, Iraq

*Corresponding author, e-mail: aws.yonis@uoninevah.edu.iq

Abstract

Next generation in wireless communication systems being deployed in the world, 5G/6G mobile and wireless communication technologies has been widely studied. This work clarifies that Millimeter-Wave (mm-Wave) is in its early stages and will be driven by consumers who keep on desire higher information rates for the consumption of media. Millimeter-Wave innovation represents for next generation cellular technology and includes a wide range of advanced features which make next innovation most dominant technology in near future, these abilities incorporate high achievable information rates in addition to lower delays and constant connectivity on wireless devices.

Keywords: BER, data rate, mmwave, PAPR

Copyright © 2019 Universitas Ahmad Dahlan. All rights reserved.

1. Introduction

Recent studies suggest that deploying fifth generation on mm-Wave presents great innovation to radio frequency engineers [1, 2]. The deploying mm-Wave frequency bands to provide a link between device and base station presents many technical challenges. Moreover, mm-Wave frequencies will provide much higher throughput, secure services, dramatically increased network capacity, and low latency [3]. At present the emerging trends of the new fifth-generation (5G) changed the traffic characteristics of communication technology in order to ensure the provision of mobile telecommunications services over the coming time due to the rapid development of communications, new technological solution must be developed to keep abreast of future developments or challenges [4]. One of the methods used to transmit data is the multi carrier modulation a technique used to achieve high data transfer, increase spectral efficiency and reduce error by dividing it into several components. To improve and achieve the highest rates of data transfer, researchers [5-7], have developed multi carrier modulation techniques which UFMC, Orthogonal frequency Division Multiplexing (OFDM) [8] and Filter-Bank Based Multi-Carrier (FBMC) are some of the technologies developed. In FBMC system the subcarriers are filtered individually, strongly strengthen the durability inter-carrier interference (ICI) effects. The defect is the length of the long filter and is therefore unsuitable for uplink communication necessary for the possible implementation of the system (5G). Such as energy efficient machine type communication (MTC) or low cost communication, Multicarrier filters sub-band blocks and classifies the subcarriers. This can significantly reduce the length of the filter, compared to FBMC. In Multicarrier, subcarrier frequency groups are filtered but not every subcarrier separately. Each set of a number of contiguous sub-bands is formed and where the range of radiation is reduced compared to OFDM without increasing the length of the code [9].

2. Millimeter Wave Evolution toward Next Generation

Every year the number of wireless-enabled devices grow at an exponential rate, the mm-Wave module provides a basic implementation of millimeter wave user and infrastructure devices which include the propagation models, physical (PHY) and (MAC), this module has been designed to provide a completely customizable simulation tool for mm-Wave devices. Nonetheless, the important features provided by the module are a basic

implementation of mm-Wave user devices and infrastructure devices (base stations), support for time division duplexing (TDD), a customizable OFDM based frame structure for data and control channels, support for downlink and uplink MAC scheduling, an outdoor mm-Wave channel model based on Figure 1 shows a schematic diagram of the mm-Wave module [10].

The chief function of the physical layer is to transmit signals sent from the upper layers over the physical channel. It is to process data and control signals received over the physical channel, and it is sent associated primitives to the upper layers. The mm-Wave module supports TDD, which is likely to be adopted in 5G cellular networks, mainly to better support relays. Figure 2 shows the structure of mmWave.

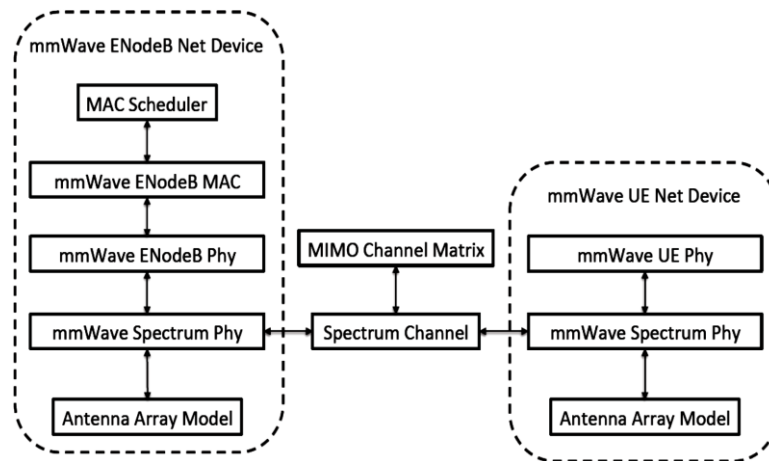

Figure 1. A schematic diagram of the mm-Wave device functionalities [11]

Mm-Wave is a promising technology for future cellular systems, since limited spectrum is available for commercial cellular systems, most research has focused on increasing spectral efficiency by using OFDM, MIMO [12], efficient channel coding, and interference coordination. Network densification has also been studied to increase area spectral efficiency, including the use of heterogeneous infrastructure but increased spectral efficiency is not enough to guarantee high user data rates. Millimeter wave (mm-Wave) cellular systems also referred to as terahertz radiation, operating in the 30-300 GHz band, above which electromagnetic radiation is considered to be low (or far) infrared light [13].

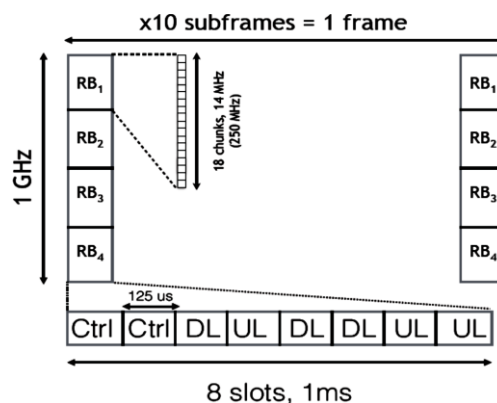

Figure 2. mmWave structure [11]

3. Millimeter-wave based Multi-carrier Waveform System

The paper focuses on the design and analysis of an Multi-carrier transceiver equipped and operating at millimeter wave carrier frequencies [14]. A future 5G candidate

telecommunication for replacing orthogonal frequency division multiplexing is filter bank based multi carrier [15]. The narrow band filter is used very much with the length of time. The advantages of the new method of regulation to create the fifth generation wireless communication system. The fifth generation of mobile communications requires more spectrum efficiency and also higher data rate. Multicarrier has less side lobes than single carrier, thereby increasing spectral efficiency [16]. So it will be attraction towards Multicarrier because it provides better sub carrier separation like filter bank multicarrier and less complexity like orthogonal frequency division multiplexing. In addition to the advantages of this technique, but have some limitations like higher Peak to Average Power Ratio (PAPR) [17, 18]. PAPR can be defined as the relation between the maximum power of a sample in a given transmitted symbol divided by the average power of that symbol. Expression No.1 can be mathematical of PAPR using this equation:

$$PAPR = \frac{\max\{|x[n]|^2\}}{E\{|x[n]|^2\}} \quad (1)$$

$|X[n]|$ belongs to the amplitude of $x[n]$ while E is the expectation of the signal. The multi-carrier waveform transmitter diagram is shown in Figure 3, the purpose of inverse fast Fourier transform (IFFT) is to ensure that the waves do not overlap [19]. Figure 4 shows the block diagram of multi-carrier waveform receiver, the used FFT is $2N$ point and it is applied on the received data from the channel.

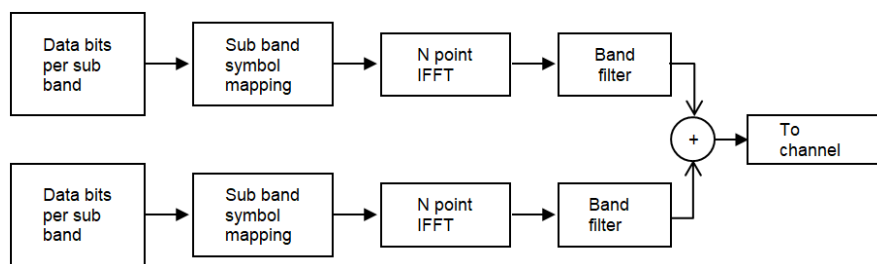

Figure 3. Multi-carrier waveform transmitter

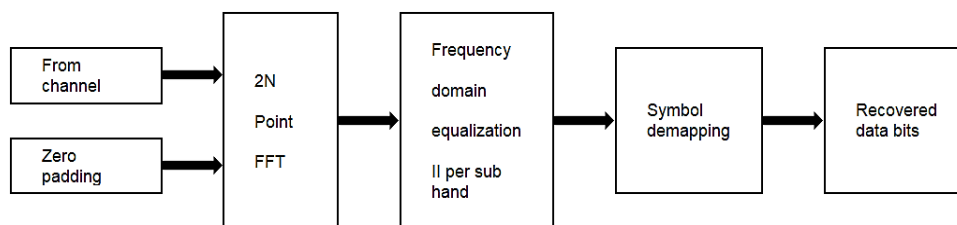

Figure 4. Multi-carrier waveform receiver

While using single carrier technique which is a standard 4G configuration orthogonal technology and is widely used for broadband connection system [20]. Single carrier characterized by that the efficiency is very high because it uses each package and works in frequency packets 5.2 GHz, which have less interference with other devices and thus we get a very high speed in data transfer up to more than 54 MBps. Despite its advantages, but there are some restriction, which makes it suffer from problems. Where it is very sensitive to the carrier frequency offset (CFO) [21]. To increase the strength against inter symbol interference (ISI) between overlapping codes due to multiple propagation on the radio channel the duration of the total symbol is appended along with a Cyclic prefix (CP). Cyclic Prefix is to add some repetitive bits at the end of each single carrier code [22]. In fact CP is the same as the tail of a symbol at the beginning. The introduction of the cyclic prefix of its spectral efficiency and average peak rate of high PAPR. Figure 5 illustrates the process of transmitter and receiver sides [23].

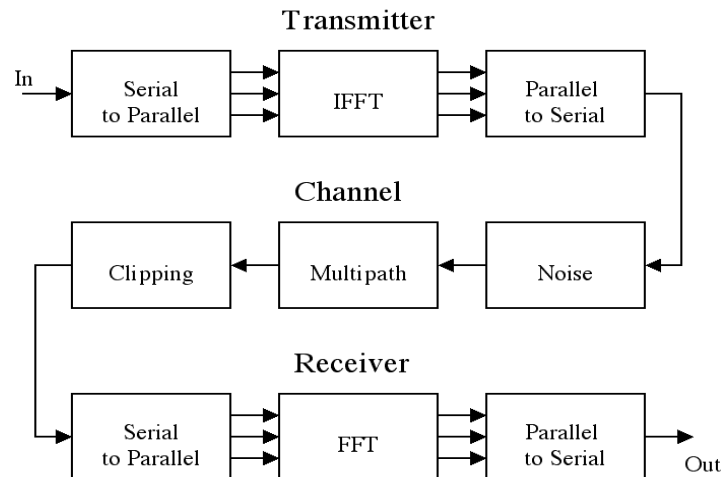

Figure 5. Block diagram of receiver and transmitter in the single carrier

4. Results and Analysis

Nowadays, millimeter-wave band refers to the frequency range from 30 to 300 GHz, which is the highest electromagnetic radiation radio frequency band, with wavelengths ranging from 1 to 100 mm [24]. In this paper, several types of modulation techniques are used to influence the Multicarrier and single carrier. The size of FFT is 1024 was used, and number of subband is 10. When using 4 QAM PAPR was 7.85 dB in Multicarrier while in single carrier it was 8.58 dB when used 16 QAM became PAPR 8.40 dB in Multicarrier while in single carrier became 8.92 dB, when 64 QAM was used, PAPR was 9.89 dB in Multicarrier while in single carrier was 9.98 dB, newer when 256 QAM was used, PAPR 7.68 dB in Multicarrier whereas in single carrier was 7.71 dB.

As shown from the obtained results above that the value of PAPR in Multicarrier is less than in single carrier technique [25]. So, Multicarrier is better than single carrier, Where the best results are obtained when the PAPR is small moreover, it is noticed from the results above that the best result was obtained when 256 QAM technique was used, from the results shown above we notice that the value of PSD in Multicarrier is equal to (-80) while in single carrier is equal to (-40), this means that the energy leakage is more in single carrier technique from the Multicarrier technique, so Multicarrier is better than single carrier. Furthermore; we notice that the increasing in bits per second leads to increasing power spectral density but the maximum change is observed in single carrier system; Figure 6 shows main results of PAPR with different values of SNR. Moreover, Table 1 shows the simulation parameters is used in Multicarrier when we used 10 subband, 20 subcarrier and other case 20 subband, 30 subcarriers. While, Table 2 shows the simulation parameters is used in single carrier-Mmwave.

The first status for both Multicarrier and single carrier is achieve lower PAPR ,the FFT size of the transmitter effects the PAPR of the system. When the FFT size increasing as the PAPR is increased. We direct our concentration toward multicarrier signals especially at mm-Wave where the bandwidths are two requests of magnitude (100x) higher than at sub 3 GHz band. We need to research that whether there is any contortion in the array reaction because of high signal data transfer capacities at mm-Wave.

We have talked about so far for example 0.6 GHz single carrier case, at that point include two different carriers at 0.9 GHz and 0.5 GHz, a significant extraordinary case, extending the data bandwidth to 500 MHz. Reception apparatus dispersing is still $\lambda/2 = 0.15$ m comparing to the inside frequency of 0.6 GHz. Moreover, the departure of array reaction from the perfect relies on both the transmission capacity of the signal ($\Delta f = f_{max} - f_{min}$) just as the center frequency (f_c). Indeed it depends on the proportion $\Delta f/f_c$ and the littler this proportion the better, Because of the high transporter frequencies at Mm-Wave the high carrier frequencies of signals has minimal effect. Figure 7 shows above the Gain of Multicarrier Mm-wave with (2, 4, 8) Elements. Moreover, Figure 8 shows BER of multicarrier Mm-wave with various QAM (256, 64, and 16), we conclude the minimum E_b/N_0 results in dB when used 16 QAM is 13 dB.

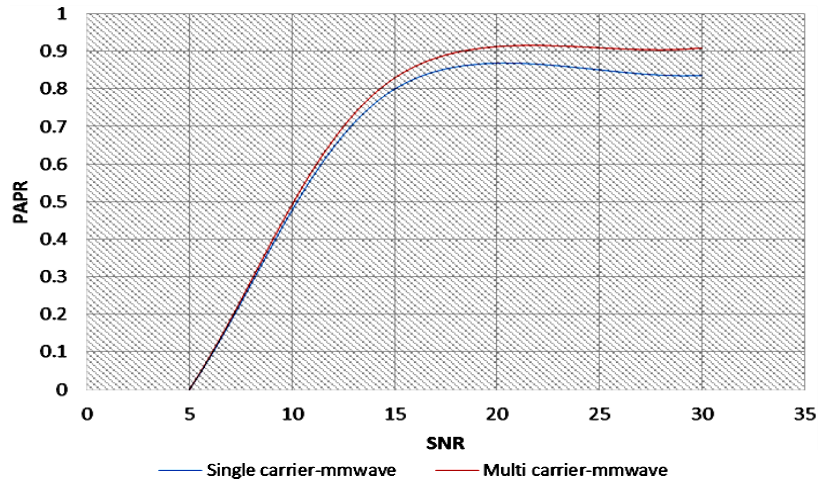

Figure 6. PAPR with different carrier-Mmwave

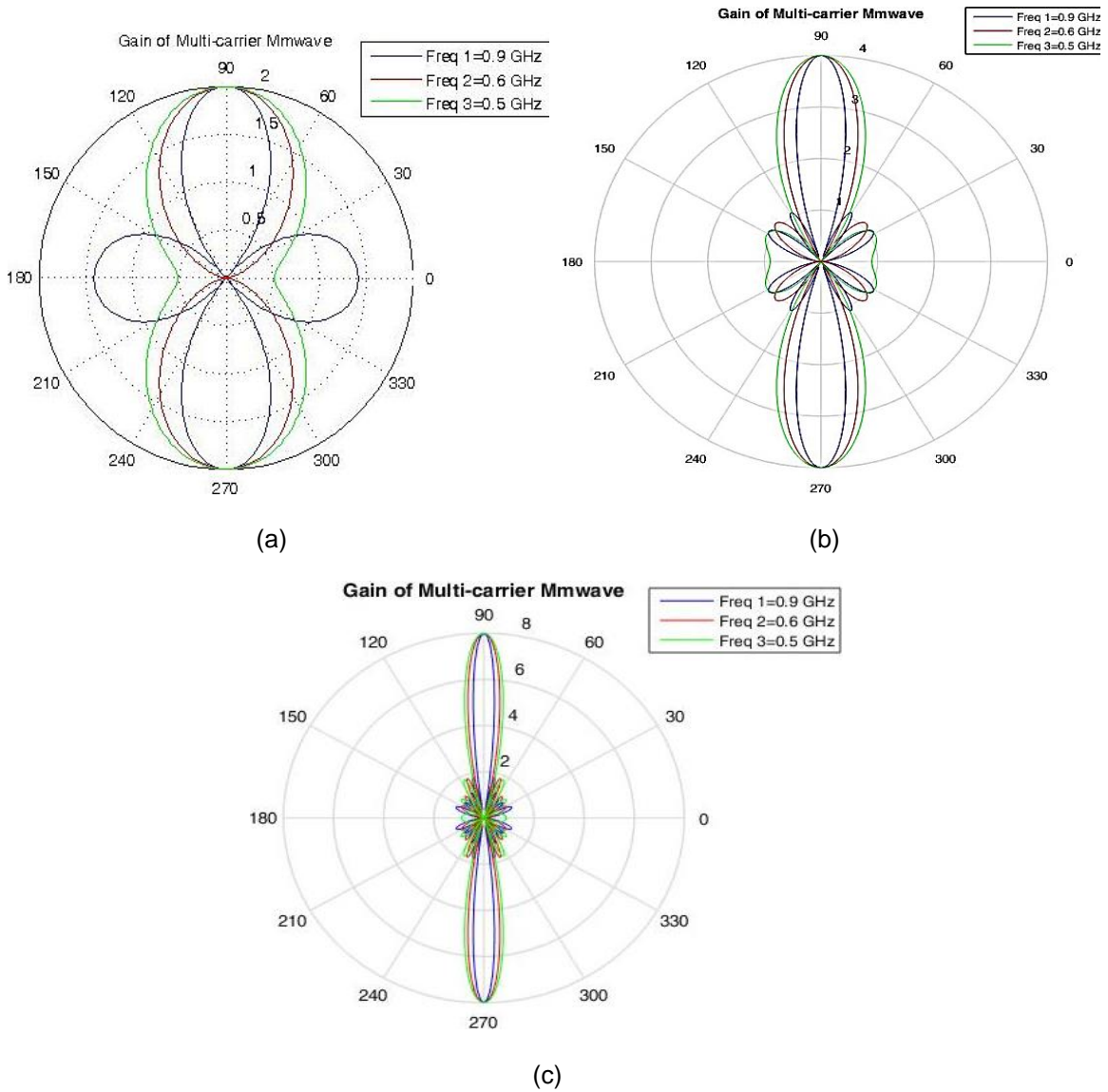

Figure 7. Gain of Multicarrier Mm-wave with (a) two, (b) four, and (c) eight elements

Table 1. Parameters used in Multicarrier Technique

| | (10 subband, 20 subcarriers) | (20 subband, 30 subcarriers) |
|--------|---------------------------------|---------------------------------|
| Numfft | 256 | 1024 |
| Offset | 28 | 212 |
| PAPR | 7.3916 | 9.7364 |
| SNR db | 15 | 15 |

Table 2. Parameters used in Single Carrier Technique

| | Single carrier- Mmwave | Single carrier- Mmwave |
|--------|---------------------------|---------------------------|
| NumFFT | 256 | 1024 |
| Offset | 28 | 212 |
| PAPR | 7.945 | 10.0501 |
| SNR dB | 15 | 15 |

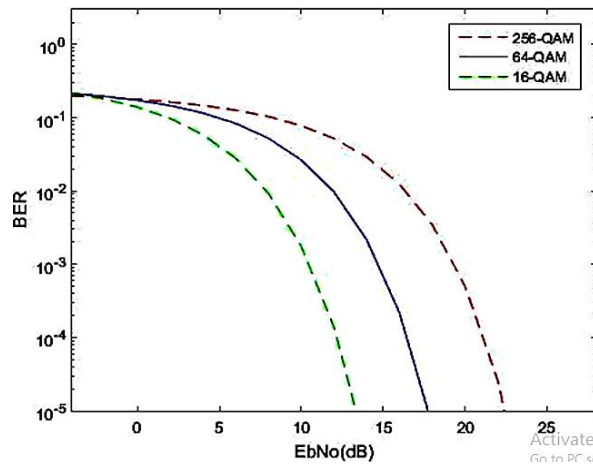

Figure 8. BER with various QAM (256, 64, and 16)

4. Conclusion

The future applications include the millimeter wave communication for the fifth generation (5G) broadband cellular communication. Millimeter-wave for wireless backhaul connections, high data rate device to device in the plane, and high precision localization systems. Research paper highlights to multicarrier system is the robust modulation candidate for 5G telecommunication system. Multicarrier systems are used type of modulation is QAM and we focus on the modulation order and effect to the Peak to Average Power Ratio (PAPR) in single carrier modulation technology has high PAPR characteristic due to the overlapping of multi carrier signal, that is why we have used Multicarrier to overcome the PAPR problem; in multicarrier Multicarrier we get value of PAPR less than single carrier. In 4 QAM both Multicarrier and single carrier have maximum value of PAPR, while when we increase the modulation order we notice a drop in values of PAPR and the best case when the order it is 256 QAM for size of FFT is 1024 according to the practical results.

References

- [1] Mezzavilla M, et al. End-to-End Simulation of 5G mmWave Networks. *IEEE Communications Surveys & Tutorials*. 2018; 20(3): 2237-2263.
- [2] Attiah ML, Isa AAM, Zakaria Z, Abdulhameed M, Mohsen MK, Dinar AM. Hybrid multi-independent mmWave MNOs assessment utilising spectrum sharing paradigm for 5G networks. *TELKOMNIKA Telecommunication Computing Electronics and Control*. 2019; 17(3): 1101-1109.
- [3] Liu D, Gaucher B, Pfeiffer U, Grzyb J. *Advanced Millimeter-Wave Technologies: Antennas, Packaging and Circuits*. John Wiley & Sons. 2009: 709-765.
- [4] Rani S, Rani N. *UFMC: The 5G Modulation Technique*. IEEE International conference on computational Intelligence and Computing Research. 2016: 1-3.
- [5] D'Andrea C, Buzzi S, Li D, Feng S. *Adaptive Data Detection in Phase-Noise Impaired MIMO-UFMC Systems at mmWave*. IEEE 29th Annual International Symposium on Personal, Indoor and Mobile Radio Communications (PIMRC). Bologna. 2018: 231-235.
- [6] Praba N, Ravikumar KM. PAPR Reduction at Large Multi-User-MIMO-OFDM using Adaptive Data Detection Algorithm. *Indonesian Journal of Electrical Engineering and Computer Science*. 2018; 12(3): 1071-1080.

- [7] Attiah ML, Isa AAM, Zakaria Z, Abdullah NF, Ismail M, Nordin R. Adaptive Multi-state Millimeter Wave Cell Selection Scheme for 5G communication. *International Journal of Electrical and Computer Engineering*. 2018; 8(5): 2967–2978.
- [8] Rakesh RT, Ranjan R, Gangwar S, Sen D, Das G. *Power Efficient OFDM-mmWave Communications with Low Resolution and Subsampling ADC*. IEEE 85th Vehicular Technology Conference (VTC Spring). Sydney. 2017: 1-6.
- [9] Rani P, Baghla S, Monga H. Effect of Transmission Parameters on PAPR of Universal Filter Multicarrier Modulation Systems. *Res Dev Material Sci*. 2017; 3(1): 2-5.
- [10] Lodro Z, Shah N, Mahar E, Tirmizi SB, Lodro M. *mmWave Novel Multiband Microstrip Patch Antenna Design for 5G Communication*. 2nd International Conference on Computing, Mathematics and Engineering Technologies (iCoMET). Sukkur, Pakistan. 2019: 1-4.
- [11] Dutta S, Zhang M, Mezzavilla M, Akdeniz MR, Rangan S. *Millimeter wave module for ns-3 network simulator*. 18th ACM International Conference on Modeling, Analysis and Simulation of Wireless and Mobile System. 2015.
- [12] Abidin ISZ, Brown TWC. *Improving MIMO multiplexing for mmWave static links*. Australian Microwave Symposium (AMS). Brisbane, QLD. 2018: 41-42.
- [13] Guan K, He D, Hrovat A, Ai B, Zhong Z, Kürner T. *Challenges and chances for smart rail mobility at mmWave and THz bands from the channels viewpoint*. 15th International Conference on ITS Telecommunications (ITST). Warsaw. 2017: 1-5.
- [14] Tsai T, Chiu M, Chao C. Sub-System SVD Hybrid Beamforming Design for Millimeter Wave Multi-Carrier Systems. *IEEE Transactions on Wireless Communications*. 2019; 18(1): 518-531.
- [15] Farhang-Boroujeny B. OFDM versus filter bank multicarrier. *IEEE signal process. Mag*. 2011; 28(3): 92-112.
- [16] Kishore K, Umar R, Naveen J. Comprehensive Analysis of UFMC with OFDM and FBMC. *Indian Journal of Science and Technology*. 2017; 10(17): 1-7.
- [17] Rani P, Baghla S, Monga H. Hybrid PAPR Reduction Scheme for Universal Filter Multi-Carrier Modulation in Next Generation Wireless System. *Res Der Material Sci*. 2017; 2(5): 3-6.
- [18] Smith JA, Cruz JR, Pinckley D. *Method for reducing the peak-to-average of a multi-carrier waveform*. VTC2000-Spring. IEEE 51st Vehicular Technology Conference Proceedings. Tokyo, Japan. 2000; 1: 542-546.
- [19] Schaich F, Wild T, Chen Y. *Wave Form Contenders for 5G-Suitability for Short Packet and Low Latency Transmissions*. Vehicular Technology conference. 2014: 1-5.
- [20] Shahjehan W, Zafar M, Hussain I, Ahmad K, Iqbal N, Altaf F. *Universal Filtered Multicarrier for 5G*. International Journal of Engineering Works. 2017; 4(7): 136-139.
- [21] Barros DJF, Kahn JM. Optimized Dispersion Compensation Using Orthogonal Frequency-Division Multiplexing. *Journal of Lightwave Technology*. 2008; 26(16): 2889-2898.
- [22] Schaich F, Wild T. *Wave Form Contenders for 5G-OFDM vs. FBMC vs. UFMC*. 2014 6th international symposium on communications, control and signal processing (ISCCSP). Athens. 2014: 457-60.
- [23] Nikopour H, et al. *Single Carrier Waveform Solution for Millimeter Wave Air Interface*. IEEE Globecom Workshops (GC Wkshps). Washington, DC. 2016: 1-6.
- [24] Cheng C, Kim S, Zajić A. *Study of Diffraction at 30 GHz, 140 GHz, and 300 GHz*. IEEE International Symposium on Antennas and Propagation & USNC/URSI National Radio Science Meeting. Boston, MA. 2018: 1553-1554.
- [25] Sumithra MG, Sarumathi M. *Comparative analysis of PAPR reduction techniques for multicarrier systems*. International Conference on Computer Communication and Informatics. Coimbatore. 2012: 1-5.