

Compact reconfigurable PIFA antenna for wireless applications

Abdullah Ali Jabber, Ali Khalid Jassim, Raad H. Thaher

Electrical Engineering Department, Al Mustansiriyh University, Iraq

Article Info

Article history:

Received Jun 28, 2019

Revised Dec 28, 2019

Accepted Feb 6, 2020

Keywords:

CST

PIFA

PIN diode

Reconfigurable antenna

VSWR

ABSTRACT

This paper presents, new compact and multiband frequency reconfigurable planar inverted-F antenna (PIFA). The antenna is designed and optimized to cover mobile application devices like GPS, WLAN/Wi-Fi, WiMAX, 4G LTE, UWB, and satellite applications. The frequency reconfigurability is obtained by using only a single RF switch (PIN diode) for changing the operating frequency. The antenna dimensions are $45.6 \times 39.6 \times 1.6 \text{ mm}^3$ printed on an FR-4 epoxy substrate with relative dielectric constant $\epsilon_r = 4.3$, loss tangent $\tan(\delta) = 0.002$ and 50Ω coaxial feed line. The proposed antenna has two patches connected by a single PIN diode. The antenna introduces nine resonant frequencies under ($S_{11} \leq -10 \text{ dB}$) which are: 0.980 GHz, 3.392 GHz, 3.924 GHz, 4.554 GHz, 5.82 GHz, 6.81 GHz, 7.305 GHz, 8 GHz and 8.105 GHz in the ON and OFF states of the PIN diode which are applicable to cover GSM900, WLAN/Wi-Fi, WiMAX, 4G LTE, UWB, and satellite systems. The obtained maximum simulated gain is 8.45 dB at 6.81 GHz. The lowest return loss is obtained to be -42 dB at 5.854 GHz. Detailed simulation and measurement results are explored and studied in this research. The CST software is used to simulate and optimize the proposed PIFA antenna. The proposed antenna has been fabricated and produced a good agreement with the simulation results.

This is an open access article under the [CC BY-SA](https://creativecommons.org/licenses/by-sa/4.0/) license.



Corresponding Author:

Abdullah Ali Jabber,

Electrical Engineering Department,

Al Mustansiriyh University, Baghdad, Iraq.

Email: aalhusseini742@gmail.com

1. INTRODUCTION

The continuous development in communications especially in the wireless communications needed more compact and multifunctional devices to be designed and applied. The communication standards like (PCS, GPS, DCS1800, UMTS, LTE2100 GSM1800/1900, Wi-Fi, and WiMAX, etc.) require to be developed by using small radio receivers with small and low profile antennas. To cover such different standards, small structures and multiband antennas are requested for such applications. The decreasing in the antenna dimensions can still while the specifications allow switching between different standards [1-10]. Microstrip patch is commonly used in the design of the PIFA antenna due to the compact size, low cost, low profile and multifunctional, more details in [11, 12]. Slot-type antennas, monopole antennas, and planar inverted-F antenna (PIFAs) are the most current multi-band antenna designs being used in mobile applications. A multiband PIFA is well-known and most likely used for mobile application devices [5]. Because of suitable Specific Absorption Rate (SAR), low profile, low cost, omnidirectional pattern, and easy fabrication the PIFA antennas are generally used for internal antenna, but it has some drawbacks such as narrow bandwidth, low gain, and low efficiency [2, 6, 13, 14]. There are four classes of reconfiguration techniques, frequency reconfigurability [3, 5, 15, 16], radiation pattern reconfigurability [17], polarization

reconfigurability [18], and the combination of them [17, 19]. Frequency reconfigurability can be achieved by using electronic switches like PIN [2, 7, 13, 20] and varactor diodes [21, 22] to adjust the frequency of operation, and by an electromechanical switch (MEMS) [1, 23]. In this paper, a new multiband and compact size frequency reconfigurable PIFA is designed to cover the operation bands of mobile application devices. The contributions behind this research are:

- A New compact frequency reconfigurable PIFA antenna with wide frequency reconfigurability range from 0.6 to 9 GHz, which is applicable to cover nine different systems such as GSM900, WLAN/Wi-Fi, WiMAX, 4G LTE, UWB, and satellite systems using only single PIN diode.
- A new compact frequency reconfigurable PIFA antenna design having a single patch and partial GND plane with areas of 33 x 30 mm² and 45.6 x 39.6 mm² respectively, which it can operate with a maximum gain of 8.43 dB.

2. PIFA ANTENNA THEORY

A rectangular element with a short metallic plate to the ground plane made up a PIFA. The first resonant frequency of the non-slotted PIFA is given by (1):

$$fr = \frac{c}{4(Lp+Hres)} \quad (1)$$

where C is the speed of light, Lp is the length and $Hres$ is the height of the radiating element [1]. The antenna takes the inverted-F shape as shown in Figure 1 (a), and it resonates at a quarter-wavelength because of the short-pin at the end. The feeding of the antenna found between the shorted and open end, and the distance from the feeding to the short-pin controls the input impedance, whenever it closed to the short-pin the impedance decreased as shown in Figure 1 (b) [24]. From Figure 1 (b) the PIFA antenna has a length ($L1$), width ($L2$), short-pin width (W), and distance (D) from the short-pin. The short-pin at high frequencies (≥ 1 GHz) introduces parallel inductance (jXL) with the antenna impedance (ZA) and it shifts the resonant frequency as shown in Figure 2.

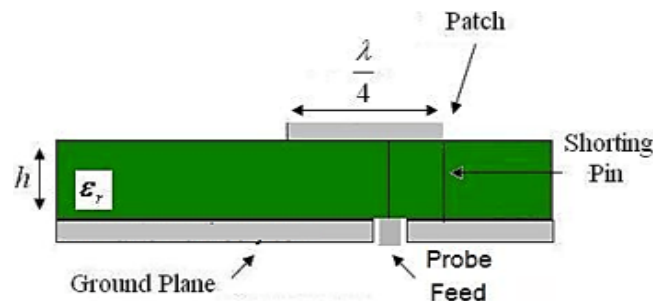

(a)

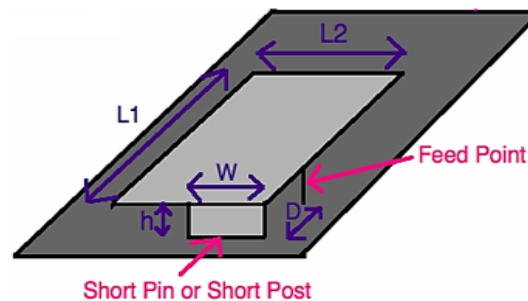

(b)

Figure 1. Planar inverted-F antenna (PIFA)

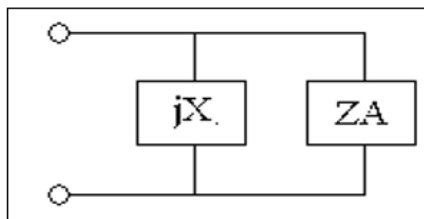

Figure 2. Equivalent circuit of PIFA antenna

The resonant frequency can be found by (2), which represents the general form of a PIFA antenna according to the far-field criteria from the farthest point on the antenna clockwise and counterclockwise the resonant frequency is given by:

$$L1 + L2 - W = \frac{\lambda}{4} \quad (2)$$

if ($W \ll L2$), W is just a pin, so (1) can be approximated to:

$$L1 + L2 = \frac{\lambda}{4} \quad (3)$$

if ($W = L2$) the antenna operates in maximum efficiency and (1) becomes:

$$L1 = \lambda/4 \quad (4)$$

after that to find the resonant frequency substitute (5):

$$Fr = \frac{c0}{\lambda\sqrt{\epsilon r}} \quad (5)$$

3. PROPOSED PIFA ANTENNA DESIGN AND PIN DIODE MODELING

3.1. Proposed PIFA antenna design

The proposed design of multiband reconfigurable PIFA can be shown in Figure 3. After the study of the latest researches and determine which applications to cover by the antenna the proposed antenna shape is chosen after some parametric study of the patch dimensions to be completely different from the literature. The antenna consists of a patch printed on an FR-4 substrate with $\epsilon r = 4.3$, $\tan(\delta) = 0.002$ relative dielectric constant and loss tangent respectively, the thickness of (1.6 mm) and 50 Ω coaxial feed line. The patch height above the ground by a distance of (1.67 mm). a short plate from the patch to the ground with (4 mm) width is produced. The overall antenna size is 45.6 x 39.6 x 1.6 mm³, which is applicable in the mobile application devices and meet the compact antenna properties and classifications. All optimum parameters of the antenna are summarized in Table 1. (4 mm) the width of the short-pin, and only single (DSM8100-000 Mesa Beam-Lead) from Skyworks PIN diode used to modify the length of the PIFA to reconfigure the resonant frequency to meet other bands of frequencies. The PIN diode is placed in an optimized position to achieve the desired operation.

3.2. Pin diode modelling

The states of the electronic switch are ON and OFF. They can be realized by biasing the PIN diode in the forward or reverse bias. At the ON state, the switch is forward bias and it has low impedance acts as a short circuit and the current can pass through the diode, while in the OFF state the switch is reversed bias and it presents a high impedance and acts as an open circuit which indicates no current flow through the diode. An electrical circuit is shown in Figure 4, which explain the forward and reverse biased, where the only resistor of (3.5 ohms) in series with an inductor of (0.15 nH) in the ON state and a combination of (1Kohm) resistor in parallel with the capacitance of (0.025 pF) all in series with an inductor of (0.15 nH) [25].

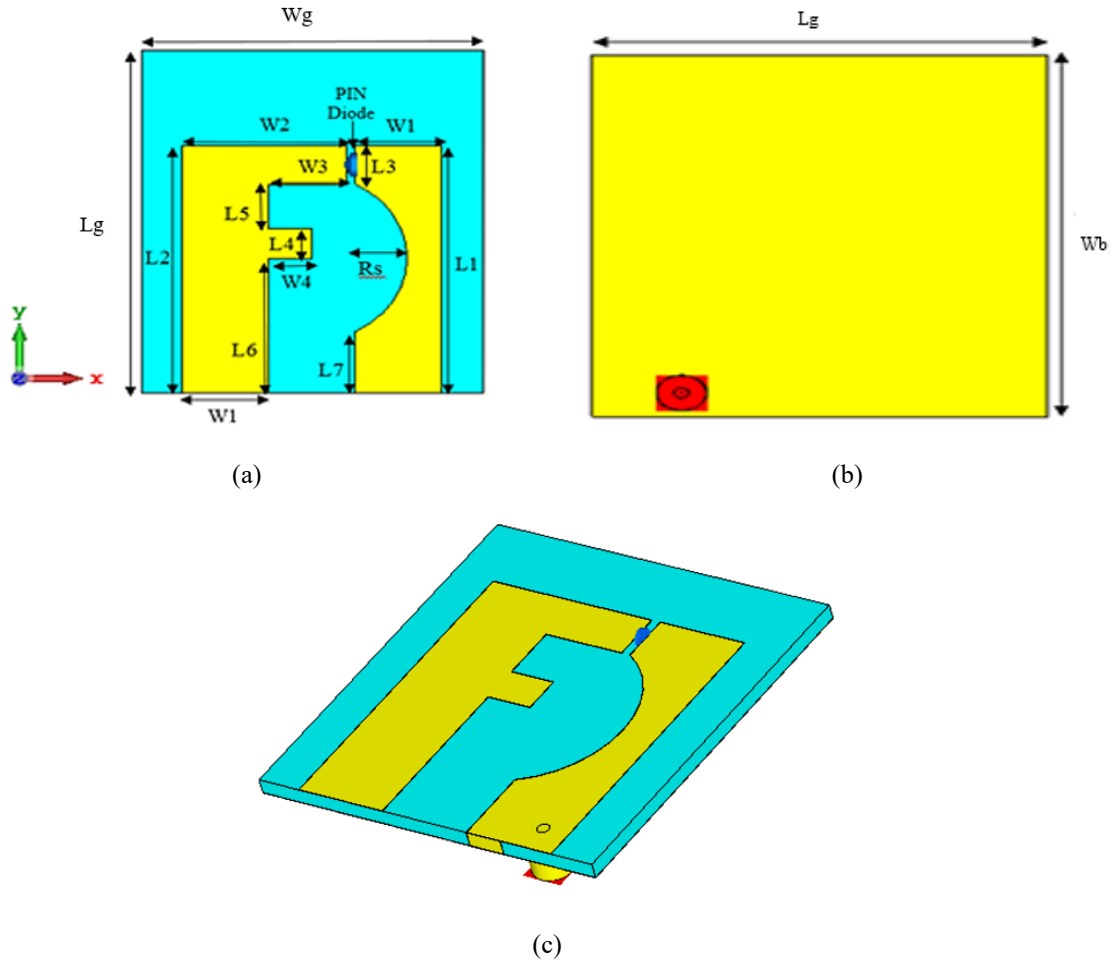

Figure 3. The proposed multiband reconfigurable PIFA antenna

Table 1. The Optimum parameters of reconfigurable PIFA antenna

Parameters	Values in mm	Parameters	Values in mm
Wg	39.6	L4	5
Lg	45.6	W4	4
L1	33	L5	5.9
W1	10	Rs	11
L2	33	t	0.035
W2	19	h	1.6
L3	5.2	L6	17.9
W3	9	L7	8.2
Ld	1	W7	10
Ws	4	Ls	1.67

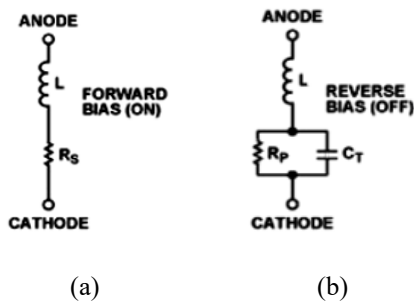

Figure 4. PIN diode modeling under (a) forward (b) reversed biased condition

4. RESULTS AND ANALYSIS

The CST software is used to simulate the proposed reconfigurable PIFA. The fabricated antenna is shown in Figure 5. The obtained simulated and measured multi-bands with the (S11) through the two states of the PIN diode is pragmatically shown in Figure 6, where obtained lowest S11 of (-39.054) in the (5.75 GHz). There are five frequency bands under the (S11 \leq -10 dB) condition have resulted in the ON state of the PIN diode, they are 0.980 GHz, 3.392 GHz, 3.924 GHz, 4.554 GHz, 5.82 GHz, 6.81 GHz, 7.305 GHz, 8 GHz, and 8.105 GHz, which are applicable to cover (GSM900, WLAN/Wi-Fi, WiMAX, 4G LTE, UWB, and satellite systems) systems, where these bands are obtained from the F-shaped sidearm of the patch, after some important parametric study on the antenna dimensions. The maximum simulated gain is (8.181) dBi at 6.81 GHz. As shown in Figure 7. The simulated VSWR of the proposed PIFA meets the practical requirements of (VSWR \leq 2) at all the multiband frequencies resulted, where the VSWR is a measure for how the line is matching with the load.

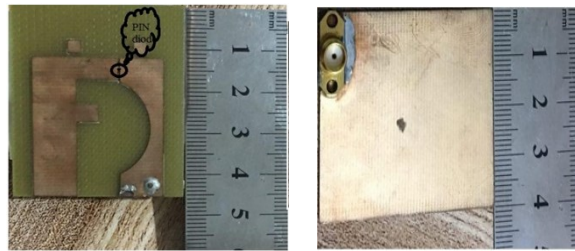

Figure 5. The fabricated PIFA antenna

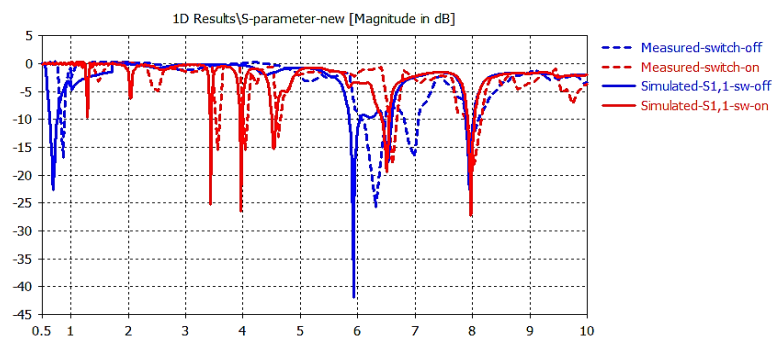

Figure 6. The simulated (S11) parameter versus frequency

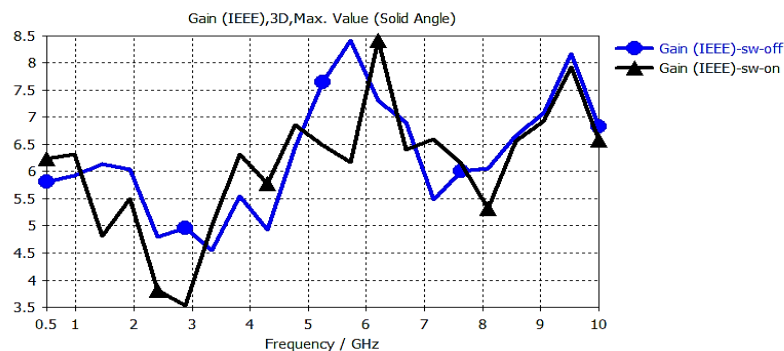
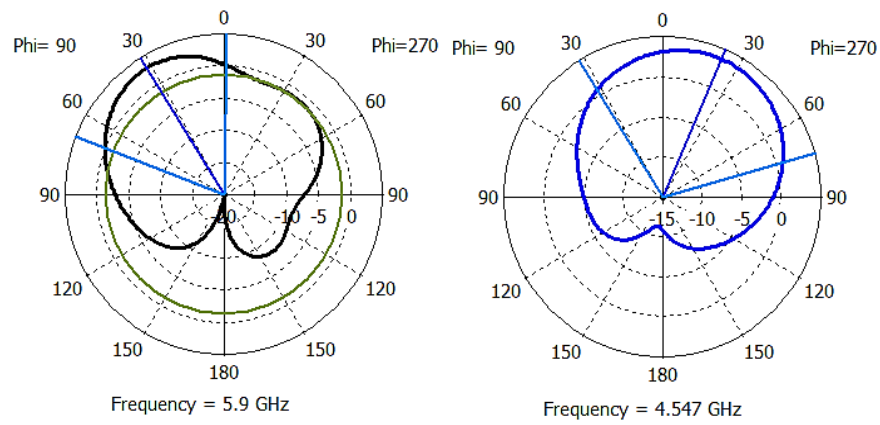
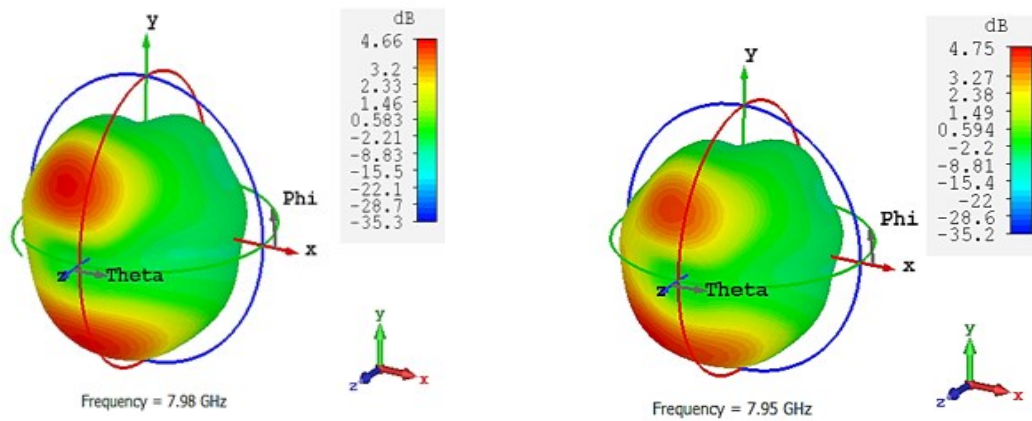

Figure 7. The gain variation with the frequency of the proposed reconfigurable PIFA antenna

The radiation pattern and surface current distribution of the proposed PIFA are shown in Figures 8 and 9 respectively, they represent the 2D/3D results. The surface current distribution presented in the left side of Figure 9 shows the OFF state of the PIN diode where no current flows to the second arm of the patch, while the other state presents the ON state. The proposed antenna can be compared with the literature to produce the strength of the system and is listed in Table 2.



(a)



(b)

Figure 8. The (2D/3D) radiation pattern of the proposed reconfigurable PIFA antenna:
 (a) 2D radiation pattern, (b) 3D radiation pattern

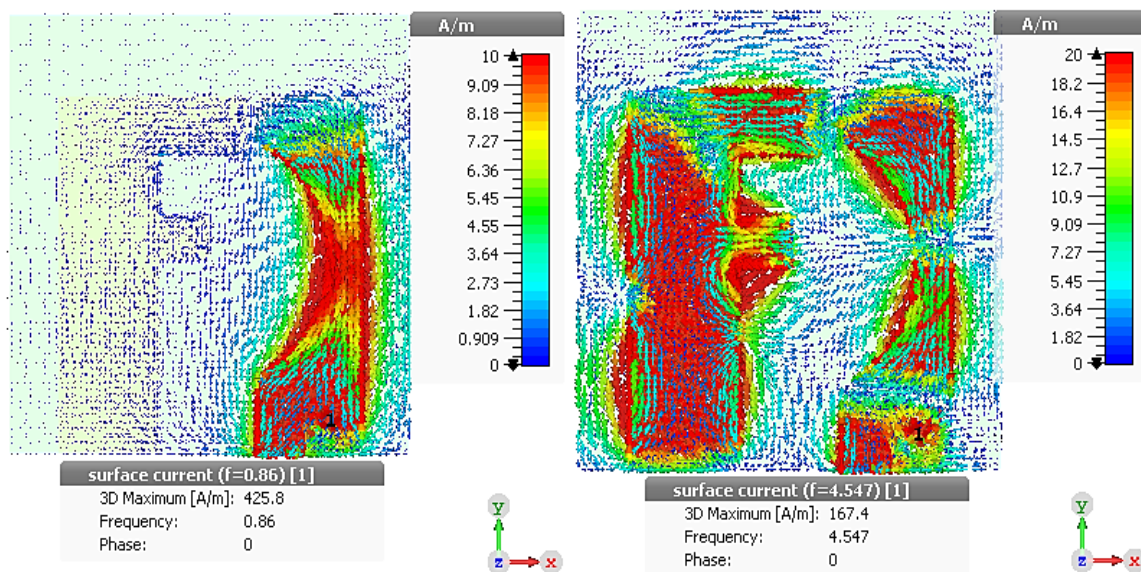

Figure 9. The (3D) surface current distribution of the proposed PIFA

Table 2. A Comparison between the proposed PIFA antenna and the literature

References	Antenna dimensions (mm ²)		No. and type of switches	Bands (GHz)	Peak gain (dB)	Applications
	GND	Patch				
2	100x60	40x16	1-PIN	0.74, 1.85, 2.17	4.62	GSM850, GSM900, DCS, PCS, UMTS, LTE
3	95x60	15x25	2-PIN	1.54-5.75	4	GPS, 3G, WiFi, GSM 4G UMTS and LTE
4	42.5x80	42.5x20	3-PIN	1.93, 2.18, 2.46, 3.58, 3.64, 5.47	6.98	GSM1800, WCDMA, m-WiMAX, WLAN
5	50x50	28x38	3-PIN	1.9, 2.1, 2.2, 2.4		Bluetooth, Wifi, WLAN, 3G, UMTS, WCDMA, GSM, CDMA
6	105x70	15x25	2-PIN	0.77, 0.9 1.54, 1.8, 2.1, 3.55, 0.980, 2.392, 3.924, 4.554, 5.2, 6.81, 7.305, 9 and 9.105	9	LTE, GSM, GPS, 3G, WiMAX, Wi-Fi
Proposed PIFA	45.6x39.6	33x30	1-PIN		8.45	GSM900, WLAN/Wi-Fi, WiMAX, 4G LTE, UWB, and satellite

5. CONCLUSION

A new compact multiband reconfigurable PIFA antenna for wireless communications application is presented in this paper with a compact to meet the requirements for mobile integration. The proposed structure operates with only a single PIN diode to obtains six resonant frequency bands appropriate for various wireless devices applications. The proposed structure is universal in the ultra-wideband frequency range (UWB) due to a compact size and planar structure, good characteristics such as gain, efficiency, radiation pattern return loss, and VSWR. The system has been fabricated and produced good agreement between the results from the simulation with the measurement one.

ACKNOWLEDGEMENTS

The authors thank Al-Mustansiriyah University for the support and the opportunity of work.

REFERENCES

- [1] Patrice Panaiat, *et al.*, "MEMS-Based Reconfigurable Antennas," *2004 IEEE International Symposium on Industrial Electronics*, vol. 1, pp. 175-179, 2004.
- [2] J. H. Lee, Y. Sung., "A Reconfigurable PIFA using A PIN-Diode for LTE/GSM850/GSM900/DCS/PCS/UMTS," *Proceedings of the 2012 IEEE International Symposium on Antennas and Propagation*, pp. 1-2, 2012.
- [3] F. A. Assadallah, *et al.*, "A Multiband and Reconfigurable PIFA for Mobile Devices," *IEEE International Symposium on Antennas and Propagation (APSURSI)*, pp. 7-12, 2016.
- [4] P. T. Minh, T. T. Thao, N. T. Duc, and V. V. Yem., "A Novel Multiband Frequency Reconfigurable PIFA Antenna," *2016 International Conference on Advanced Technologies for Communications (ATC)*, pp. 7-12, 2016.
- [5] Vinutha B, N. Kumari, Rakshitha V., and Bhavana B., "Design of Frequency Reconfigurable Antenna for Mobile Communication," *Int. Journal of Latest Research in Engineering and Technology (IJLRET)*, pp. 124-128, 2016.
- [6] F. A. Asadallah, J. Costantine, and Y. Tawk, "A Multiband Compact Reconfigurable PIFA Based on Nested Slots," *IEEE Antennas and Wireless Propagation Letters*, vol. 17, no. 2, pp. 331-334, 2018.
- [7] A. M. Khade, and A. S. Deshpande, "Review on Frequency Reconfigurable Planar Inverted F Antenna," *IOSR Journal of Electronics and Communication Engineering (IOSR-JECE)*, vol. 13, pp. 51-53, 2018.
- [8] Hattan F., *et al.*, "Reconfigurable Penta-Band PIFA for Small and Slim Mobile Handsets," *Microwave and Optical Technology Letters*; vol. 54, no. 3, pp. 725-729, 2012.
- [9] M. Liu and B. Zhao, "Dual-Feed Small-Size Penta-Band PIFA for LTE/WWAN Mobile Handset Applications," *International Journal of Antennas and Propagation*, vol. 2014, pp. 1-7, 2014.
- [10] H. F. A. Tarboush, R. Nilavalan, and T. Peter, "PIFA based Reconfigurable Multiband Antenna for Wireless Applications," *2010 Int. Conf. on Electromagnetics in Advan Application (ICEAA)*, 2010.
- [11] A. K. Jassim, and R. H. Thaher, "Design and Analysis of Broadband Elliptical Microstrip Patch Antenna for Wireless Communication," *TELKOMNIKA Telecommunication Computing Electronics and Control*, vol. 16, no. 6, pp. 2493-2500, 2018.
- [12] A. K. Jassim, and R. H. Thaher, "Enhancement Gain of broadband Elliptical Microstrip Patch Array Antenna with Mutual Coupling for Wireless Communication," *IJECS*, vol. 13, no. 1, pp. 401-408, 2019.
- [13] J. H. Lim, Z. J. Jin, and T. Y. Yun, "A Frequency Reconfigurable PIFA Using a PIN Diode for Mobile-WiMAX Applications," *IEEE MTT-S Int. Microwave Workshop Series on Intel. Radio for Future Personal Terminals*, 2011.
- [14] M. A. Al-alaa, H. A. Elsadek, and E. A. Abdallah, "Effects of Human Head on Frequency Reconfigurable PIFA Antenna Performance and SAR Calculations," *IEEE MTT-S International Conference on Numerical Electromagnetic and Multiphysics Modeling and Optimization (NEMO)*, 2015.

- [15] J. M. Floc'h and I. Ben Trad, "Printed Planar Double Inverted-F Antenna with Large Frequency Reconfigurability Range," *47th European Microwave Conference (EuMC)*, pp. 1289-1292, 2017.
- [16] J. M. Floc'h and I. Ben Trad, "Printed Frequency Reconfigurable Planar Inverted-F Antenna for ISM Applications," *IEEE Loughborough Antennas & Propagation Conference (LAPC)*, 2016.
- [17] K. Yang, *et al.*, "Printed Inverted-F Antenna with Reconfigurable Pattern and Polarization," *IEEE 10th European Conference on Antennas and Propagation (EuCAP)*, 2016.
- [18] H. Wong, W. Lin, L. Huitema, and E. Arnaud, "Multi-Polarization Reconfigurable Antenna for Wireless Biomedical System," *IEEE Transactions on Biomedical Circuits and Systems*; pp. 1-9, 2017.
- [19] A. Ghaffar, X. J. Li, and Boon-Chong Seet, "Dual Frequency Band and Polarization Reconfigurable Antenna for Mobile Devices," *17th IEEE International Conference on Communication Technology*, pp. 696-700, 2017.
- [20] Trong Duc Nguyen, Yvan Duroc, Van Yem Vu, and Tan Phu Vuong, "Frequency Reconfigurable PIFA Antenna Driven By Microcontroller," *Conference: Communications and Electronics (ICCE)*, pp. 406-410, 2012.
- [21] M. -J. Lee, Y. -S. Kim, and Y. Sung, "Frequency Reconfigurable Planar Inverted-F Antenna (PIFA) For Cell-Phone Applications," *Progress in Electromagnetics Research C*, vol. 32, pp. 27-41, 2012.
- [22] M. N. M. Kehn, O. Quevedo-Teruel, and E. Rajo-Iglesias, "Reconfigurable Loaded Planar Inverted-F Antenna Using Varactor Diodes," *IEEE Antennas and Wireless Propagation Letters*, vol. 10, pp. 466-568, 2011.
- [23] M. Unlu, *et al.*, "Reconfigurable, Tri-band RF MEMS PIFA Antenna," *2011 IEEE International Symposium on Antennas and Propagation (APSURSI)*, pp. 1563-1565, 2011.
- [24] S. Shaheen, S. Dharanya, V. Divya, and A. Umamakeswari, "Design of PIFA Antenna for Medical Applications," *International Journal of Engineering and Technology (IJET)*, vol. 5, no. 1; pp. 127-132, 2013.
- [25] Skyworks, "Data Sheet DSM8100-000: Mesa Beam-Lead PIN Diode Applications," *Skyworks Solutions, Inc*, pp. 1-5, 2008.

BIOGRAPHIES OF AUTHORS



Mr. Abdullah Ali Jabber, he was born in Hilla-Iraq in 1992. He has the B.Sc. in Electrical Engineering Department in Babylon University/College of Engineering at 2013 in Iraq, and M.Sc. in Babylon University/College of Engineering/Electronic and Communications Engineering at 2016 in Iraq, and now he is a P.h.D student at Mustansiriyh University/College of Engineering/Electrical Engineering Department with specialization in Communications Engineering. Research Interests in mobile Healthcare systems, Communication systems, Electronics, Antennas.



Dr. Ali Khalid Jassim, he was born in Baghdad-Iraq. He has the B.Sc. from Electrical Engineering Department, Al Mustansiryha University, Baghdad, Iraq in 1999 and the M.Sc. in Electrical Engineering Department, Al Mustansiryha University, Baghdad, Iraq 2010 and P.h.D. Electrical Engineering Department, Al Mustansiryha University, Baghdad, Iraq in 2019. He is a lecturer, in Electrical Engineering Department, Al Mustansiryha University, Baghdad, Iraq. My interest research field is communication and antenna.



Prof. Dr. Raad Hamdan Thaher, he was born in Baghdad-Iraq in 1956. He has the M.Sc. at 1981 in Iraq, and P.h.D. at 1997 in Romania-Bucharest. He works as a Profesor in Mustansiriyah University/College of Engineering/Electrical Engineering Department, Baghdad, Iraq. His Specializations Electronic Communication Engineering and his research Interests in Communication systems, Electronics, Microwaves, Antennas, and Communication networks.