

OFDM synchronization system using wavelet transform for symbol rate detection

Masaru Sawada¹, Quang Ngoc Nguyen², Mohammed Mustafa Alhasani³, Cutifa Safitri⁴, Takuro Sato⁵

^{1,2,3,5}Department of Communications and Computer Engineering, Waseda University, Japan

⁴Faculty of Computing, President University, Indonesia

Article Info

Article history:

Received Aug 15, 2019

Revised Jan 24, 2020

Accepted Feb 24, 2020

Keywords:

Orthogonal frequency-division multiplexing (OFDM)

Symbol rate detection

Synchronization

Timing recovery system (TRS)

Wavelet

ABSTRACT

In radio communications, using wavelet signal analysis to recover the symbol rate timing clock of orthogonal frequency-division multiplexing (OFDM) is a new approach that can tolerate signal distortion from intersymbol interference (ISI) and intercarrier interference of encoding digital data on multiple carrier frequencies. Typically, the reception synchronization with wavelet signal analysis in OFDM can improve the performance over the fourier transform-based OFDM. However, a synchronization procedure that is stable against distortion and noise is essential to diminish the symbol synchronization establishment and operation sampling period. In this paper, we propose an OFDM synchronization system and analyze the impact of the wavelet denoise procedure on the OFDM system, which extracts the symbol rate of the OFDM frame. The evaluation results show that the proposed system can optimize the frequency window size to enable an efficient timing and frequency offset estimation with high and stable performance in terms of bit error rate (BER) and Frame Error Rate (FER) especially when the value of E_b/N_0 (a normalized signal-to-noise ratio SNR measure) is greater than 8 dB, thanks to the wavelet transform.

This is an open access article under the [CC BY-SA](https://creativecommons.org/licenses/by-sa/4.0/) license.



Corresponding Author:

Quang Ngoc Nguyen,
Department of Communications and Computer Engineering,
Faculty of Science and Engineering, Waseda University,
1 Chome-104 Totsukamachi, Shinjuku City, Tokyo 169-8050, Japan.
Email: quang.nguyen@aoni.waseda.jp

1. INTRODUCTION

Nowadays, the Internet is shifting from host-centric to content-centric model as users are interested in the content, instead of the location. In this context, information-centric networking (ICN) concept has introduced a new promising Internet architecture to solve the current host-centric Internet's severe problems of security and inefficiencies in content delivery. The reason is that in ICN, requested content data can be accessed from a replica via the in-network caching feature, instead of the only content source as in current IP-based Internet architecture. However, in-network caching capability in ICN also raises new challenges, especially energy efficiency (EE) issue due to the extra energy needed for the content routers and their in-network caching operation [1-3]. Worse still, the default caching scheme in ICN, leave-copy-everywhere (LCE) with least recently used (LRU), is a relatively inefficient mechanism which causes high cache redundancy (due to low cache diversity) [4, 5] and congestion rate (due to packet flooding) [6, 7] as well, as analyzed in our prior studies. These issues become more challenging with the rapid increase in price for energy consumption, the number of broadband wireless network users, as well as the growing demand of the content

users in the future network. As a result, although ICN enables an effective content delivery platform [8], it still faces several feasibility concerns towards future network access, especially in the case of wireless communications.

In this context, as 5G communications will be officially launched soon, an efficient communication system with low, latency, and ultra-reliability should be considered to meet the requirement of 5G technology, particularly in the design of the modulation and demodulation techniques. Currently, though several access techniques can be considered as a candidate of 5G technology, e.g., non-orthogonal multiple access (NOMA), orthogonal multiple access (OMA) or multiple-input multiple-output (MIMO) [9], Orthogonal frequency-division multiplexing (OFDM) is still challenging for realizing the feasible 5G communications due to the out of band leakage (OOB). Typically, the guard interval discrete Fourier transform spread OFDM, namely GI DFT-s-OFDM, and spectrally-preceded OFDM (SP-OFDM) are feasible candidates for OFDM technology to be applied in 5G [10]. However, the frequency and phase synchronization are among the most challenging aspects to enable low latency and ultra-reliability in the OFDM system. Recently, the traditional OFDM is applied in the Wi-Fi standard of IEEE 802.11 to increase the data rate and capacity. This OFDM approach also uses synchronization conducted with the physical layer convergence procedure (PLCP).

To improve communication capability with low error rate in OFDM wireless communications, a receiver signal processing system which eliminates the interference between symbols of multiples carriers, an equalizer that compensates for propagation path distortion, and synchronization which can capture and track the symbol rate clock of received signal within preamble periods are essential. To address these challenges, this research proposes a wavelet denoise procedure that selects the OFDM signal frequency range without changing the frequency characteristic of the symbol signal to minimize the interference between symbols and carriers. Typically, we redefine an OFDM symbol signal, including the Hilbert space that is a linear space with an inner product. The OFDM frame is composed of the preamble symbol and the data symbol. The gap between the adjacent symbols is a discontinuous point in the frame signal, and the roll-off of both sides of the symbol signal moderates the rapid change within the gap. The wavelet signal processing transforms a signal into time and frequency domains in one space, called signal space. In this way, the proposed system can select a frequency range and reduce the noise power without changing the known preamble pattern. Also, the evaluation results by means of computer simulations show the improvement of this system in additive white Gaussian noise (AWGN) channel thanks to a better subcarrier recovery and frequency synchronization. In short, the contribution of this research is as follows.

Based on the wavelet signal analysis and recovery theory, we propose a method to establish synchronization by projecting the received signal into the signal space of the orthogonal basis of the receiver clock system. Instead of the conventional timing recovery system (TRS) based on feedback loop control, we propose a TRS system corresponding to the signal projection using asynchronous oversampling to realize an efficient symbol rate timing. The transmission/reception system, frequency conversion, and propagation path characteristics are defined by the integral conversion.

To reproduce the encoded signal synchronized with the transmission clock, the reception system detects the frequency and phase of the transmission clock from the reception signal and includes the function of establishing synchronization with the reception signal, which is represented by a discrete-time signal processing model. Typically, the proposed method extracts a clock waveform synchronized with a symbol rate due to denoising by multi-resolution analysis for detecting discontinuity between symbols. The proposed algorithm for extracting channel distortion and frequency offset using wavelet analysis is a promising approach, given that the OFDM model construction method with timing recovery and frequency synchronization can be applied to various communication systems, such as broadcasting systems [11, 12], optical communications [13] or long term evolution (LTE) network [14].

2. RELATED WORK

OFDM is a widely-used technique in wireless communications to match demand for high data rates and increase the capacity of the channel. The concept of OFDM is to transmit the signals orthogonally through multiple sub-channels by using the fast Fourier transform (FFT) and inverse fast Fourier transform (IFFT) [15]. The traditional OFDM is currently challenging to be utilized for modulation in 5G technology due to the three main reasons. Firstly, the high spectral efficiency is needed to reduce the out of band (OOB) leakage. Next, loss synchronization requires a lot of clients to use the same scheme at the same time. Finally, the OFDM system also requires the efficient usage of the symbol period and subcarrier width to ensure the system feasibility and flexibility.

The guard interval discrete Fourier transform spread OFDM, namely GI DFT-s-OFDM, is used to reduce OOB leakage by identifying the sequence of GI instead of CP (cyclic prefix). Moreover, by knowing the GI sequence, we can estimate the carrier frequency offset, which is an essential parameter in the synchronization

processing. In our prior work, we applied OFDM-GI in the 4-SSB modulation domain, which is a novel modulation technique to double the amount of information compared to traditional single-sideband [16, 17]. The results showed good performance in the receiver by minimizing the effect of ISI (intersymbol interference) induced by Hilbert Transform. However, the limitation of this approach is that we still use the signal pulse shaping depending on the IFFT/FFT transform for estimating the pulse shape and the band filtering. Hence, researchers in [18] proposed an alternative OFDM-based method by replacing the FFT algorithm with the wavelet transform.

FFT-based OFDM uses CP to prevent ISI between adjacent OFDM symbols. ISI is derived from a discontinuous subcarrier that loses the periodical signal characteristic. The spectrum spread of the sub-carrier causes the length of the symbol corresponding to the uncertainty principle. However, CP affects the spectral efficiency, and using IFFT in the transceiver is impractical for the case of low frequency (flat) fading. Besides, the OFDM demodulator needs an equalizer to compensate for a symbol window function that limits the length of a symbol signal before FFT for the recovery of the constellation maps of sub-carriers. Optimal sampling timing is also necessary to mitigate inter-carrier interference (ICI), but the drawback of this method is the coarse symbol clock recovery from a known preamble pattern at the head of a frame.

As the wavelet-based OFDM has higher bandwidth efficiency and can gain better bit error rate (BER) performance than the conventional OFDM in fading channels [19] and carrier frequency offset with phase noise [20], in this paper, we propose a new method for the synchronization of OFDM using wavelet transform. This proposal is a potential approach, given that detecting the clock symbol rate is critical for OFDM receiver clock [21] and using the wavelet for high resolution of frequency is a suitable solution for low-frequency channel, e.g., the well-known wavelet transforms namely Haar and Daubechies wavelet used in discrete signals [22]. The results show that the wavelet transform is feasible and promising toward 5G communications by using the extracted frequency domain for symbol clock rate detection.

3. SYSTEM MODEL

In this section, we present the system model design, which reduces the additive noise from the frame by deconstructing and reconstructing a received signal. The preamble of the frame is a periodical and known pattern which is used to detect the coarse symbol timing using the correlation between the received signal and the reference preamble pattern. Wavelet transforms the received signal noise into time and frequency in the two-dimensional (2D) space in which the frequency range can be selected in the wavelet transformed signal and acts as a bandpass filter without distorting the original received signal. The inverse wavelet transform then reconstructs the original signal with the reduced noise.

3.1. Overall OFDM transmission and reception system configuration

In this part, we developed an OFDM synchronization model derived from Mathworks Matlab as an OFDM configuration model for data transmission and reception (conformed to the IEEE 802.11a standard). The wireless communication model is shown in Figure 1, including a transmitter, a receiver, and a propagation path model. The conventional OFDM model constructs a theoretical expression model of the subcarrier frequency multiplexing scheme by Fourier series expansion of a periodic function. The symbol rate signal of OFDM has a continuous waveform in which orthogonal subcarriers are modulated quadrature amplitude modulation (QAM) or phase-shift keying (PSK). Particularly, QAM or PSK can be defined as a function map from binary code to a complex number point (d_k) on the constellation map where $d_k \in \mathbb{C}$, $0 \leq k \leq N - 1$ (N : number of channels).

In OFDM, a frame signal consists of preamble symbols signal and data symbols. The frame signal has discontinuities points between adjacent symbols, which spread unexpected frequency. The symbol signals include a finite period and energy signal space, named as symbol signal space (SSS). SSS is proposed in a complex linear space with an inner product corresponding to a Hilbert space configuration. N channel subcarrier signals allocated at interval of Δf (Hz) is considered as the orthogonal basis $\{e^{j2\pi\Delta fkt}\}$.

The fourier transform-based OFDM transmit signal ($s_{TX}(t)$) can define the fourier transform of OFDM reception processing with the rapidly decreasing function space and the inverse fourier transform of the transmission processing. We also apply the sampling theory into the OFDM receiver processing using a slowly increasing hyperfunction space. Synchronization of digital data in wireless communication is a system in which transmission data is sampled at an optimum timing concerning a reception signal obtained by transmitting a signal (from a transmitter) via a communication channel, and data is reproduced. The propagation path model is an analog signal processing model in which additive random noise is superimposed on a signal with attenuation by signal power, signal filter by transfer characteristics. A signal by propagation path has a plurality of delay times for a finite-length transmission signal. The reception system amplifies the power of the received signal affected by the propagation path and compensates for the distortion of the signal by equalizing the propagation path characteristics. Also, the influence of the received signal of different delay times causes

superimposed then reduces the random noise. The receiver system also detects the frequency and phase of the transmission clock from the reception signal to recover the encoded signal synchronized with the transmission clock and includes an analog-to-digital conversion and a function of synchronization establishment with the reception signal. It is represented by a discrete-time signal processing model.

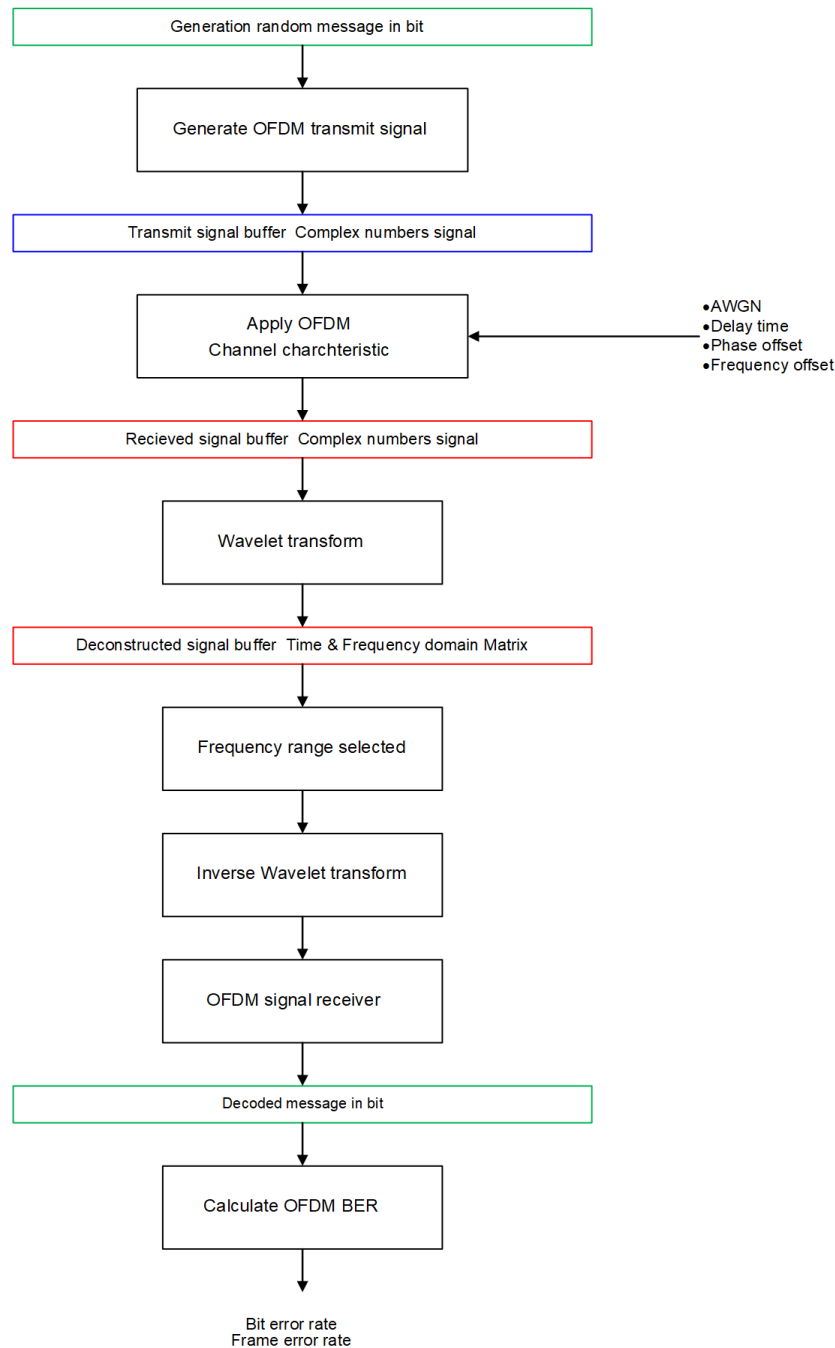

Figure 1. The OFDM synchronization bit error rate (BER) configuration model

In general, it is necessary to synchronize with the symbol rate, the frequency conversion local frequency, and the sampling timing. In this paper, to detect the symbol clock rate of the symbol for efficient data transmission, we propose a mechanism that establishes synchronization by projecting received signal onto the complex signal space of the orthonormal base of the receiver clock system based on wavelet signal analysis and the kernel reproduction theory. In section 4, we propose a Symbol rate timing model as a method to extract a clock waveform synchronized with a symbol rate by the de-noise procedure. The proposal uses a multiresolution analysis that

detects discontinuities between symbols. In addition, we propose a timing recovery system (TRS) method based on the signal projection by asynchronous oversampling instead of using the conventional feedback loop control. The transmission/reception system, frequency conversion, and propagation path characteristics are defined by the integral conversion.

3.2. The analog theoretical model of OFDM transmission and reception

The analog theoretical model for transmission and reception shown in Figure 2 includes baseband signal processing with a DC (direct current) component and passband signal processing that is frequency-converted to the RF band of the propagation path. The baseband OFDM signal is modeled by a complex signal, and the OFDM modulation/demodulation was modeled by the (inverse) Fourier transform. The conventional OFDM transmission theoretical model modeled by inverse Fourier transform (IFFT) lays a foundation for the modulation signal processing of the transmission of the frequency-multiplexed symbols, baseband signal processing, and passband signal processing for performing wireless communication.

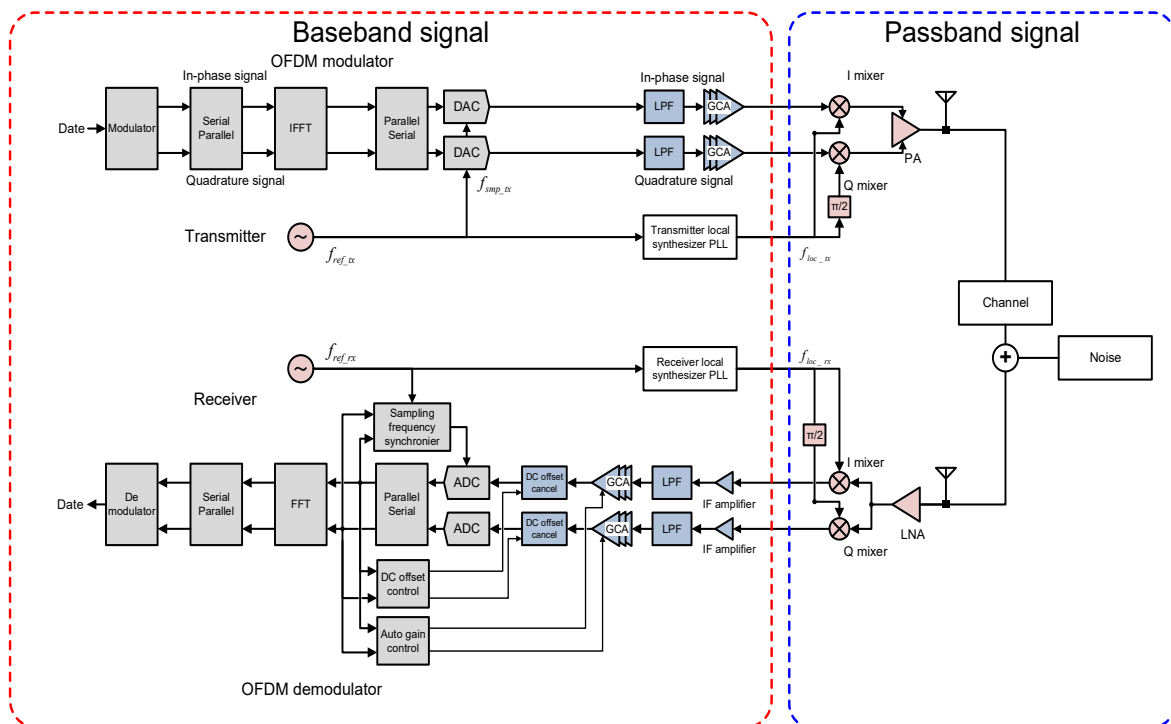

Figure 2. OFDM transmitter, receiver and RF propagation path

An OFDM transmission signal of an N subcarrier signal channels is mapped to a signal space spanned by an orthogonal basis ($e^{j2\pi\Delta fkt}$) with k^{th} subcarrier where $k = (0, 1, 2, \dots, N - 1)$. Propagation characteristic and additive white Gaussian noise (AWGN) of wireless communication are defined for passband signals in the RF band. By defining the conversion gain between the baseband and the passband, the propagation path characteristics and AWGN can be defined by a model equivalent to the baseband without depending on the carrier frequency of the passband. A transmission mixer that performs up-conversion is represented by multiplication of a carrier and a baseband transmission real signal, and the reception mixer frequency-converts the passband real value signal into a baseband complex signal using in-phase/quadrature signal (I/Q signal) reception methods.

The coefficients of the orthogonal basis to the subcarrier are coefficients of the complex signal ($d_k \in \mathbb{C}$) mapped to the constellation of QAM (quadrature amplitude modulation) and QPSK (Quadrature phase shift keying) modulation with the serial signal after signal coding corresponding to the Fourier transform are presented in (1) and (2) as follows:

$$s_{TX}(t) = \chi_{[0, T_S]}(t) \left(\sum_{k=0}^{N-1} d_k \cdot e^{j2\pi k \Delta f t} \right) \quad T_S = \frac{1}{f_s}, \quad s_{TX}(t) \in \mathbb{C}[0, T_S] \quad (1)$$

$$\text{where } \chi_{[0, T_S]}(t) = \begin{cases} 1 & |t| \leq T_S \\ 0 & |t| > T_S \end{cases} \quad (2)$$

$$\text{where } w_{TSYM}(t) = \begin{cases} \sin^2\left(\frac{\pi}{2}\left(0.5 + \frac{t}{T_{TR}}\right)\right) \\ 1 \\ \sin^2\left(\frac{\pi}{2}\left(-0.5(t - T_{SYM}) + \frac{t}{T_{TR}}\right)\right) \end{cases}$$

Typically, OFDM forms a finite-dimensional signal space with N-channel subcarriers, and symbol signals are represented by coefficient vectors $\{d_k\}$ of the constellation map. The symbol signal is included in a complex-valued continuous function C on a bounded closed interval [a, b], and is expressed as a signal space spanned by an Nth-order basis. The window function is an ideal rectangular pulse function ($\chi_{[0, T_s]}(t)$) with the time domain for I/Q signal (16 channels) as depicted in Figure 3, and $w_{TSYM}(t)$ characteristic in time and frequency domain is illustrated in Figure 4 (T_{SYM} denotes the sampling period). Also, due to the discontinuity between adjacent symbol signals, the window function (w_{TSYM}) that alleviates discontinuity has a roll-off frequency characteristic of the frame when the signal is slightly attenuated at both ends of the symbol signal, as shown in (2).

Also, the pilot signal (p_l) is a known periodic signal included in the constellation (d_k):

$$Tp(t) = Re(\chi_{[0, T_s]}(t)(\sum_{k=0}^{N_{SD}-1} d_k \cdot e^{j2\pi k f_s t})e^{j2\pi k f_{Loc} t}) \tag{3}$$

where $T_s = \frac{1}{f_s}$ and $Tp(t) \in \mathbb{R}$. Figure 2 also shows the transmitter and receiver analog signal model with the mixer performing frequency shift operation where the baseband signal is converted to a passband frequency of the RF band by the upconversion mixer at the local frequency (f_{Lo} (Hz)) and transmitted as a passband signal $Tp(t)$. In this way, the receiving system amplifies the power of the received signal affected by the propagation path and compensates for the distortion of the signal by equalizing the propagation path characteristics.

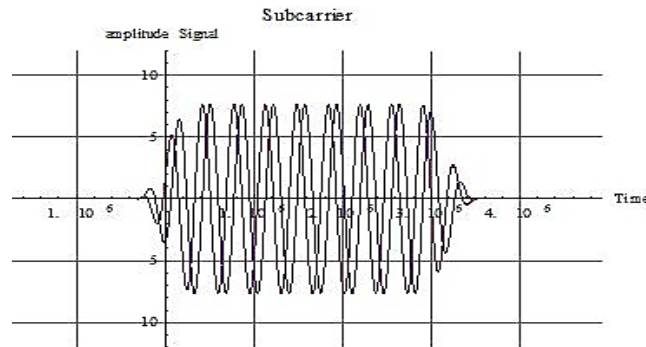

Figure 3. Time-domain I/Q signal (16 channels)

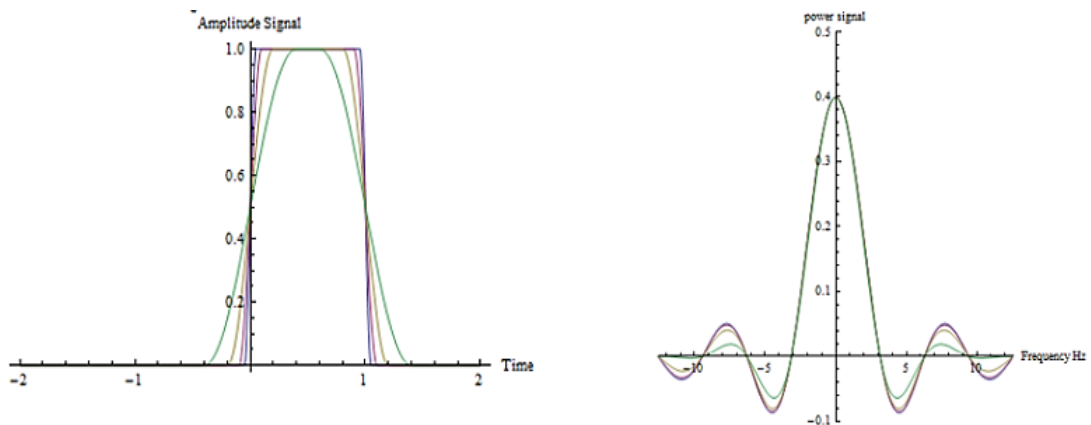

Figure 4. $w_{TSYM}(t)$ characteristic in time and frequency domain

3.3. The OFDM processing system model

We develop an orthogonal frequency division multiplexing (OFDM) signal processing model based on the IEEE 802.11a standard [23] under the assumption that the subcarrier and carrier frequency are synchronized among the transceivers [24]. Next, we propose an algorithm to detect the carrier frequency offset from an asynchronous system between the transmitter and receiver to realize a synchronous system. Particularly, the algorithm can detect the frequency offset between the transceivers from the periodical and known preambles in the received signal form using the wavelet signal analysis. The overall IEEE 802.11a OFDM layer configuration is depicted in Figure 5, in which the beginning of the packet is detected from the periodical signal of the preamble to acquire and track the carrier frequency and subcarrier frequency between the transceivers.

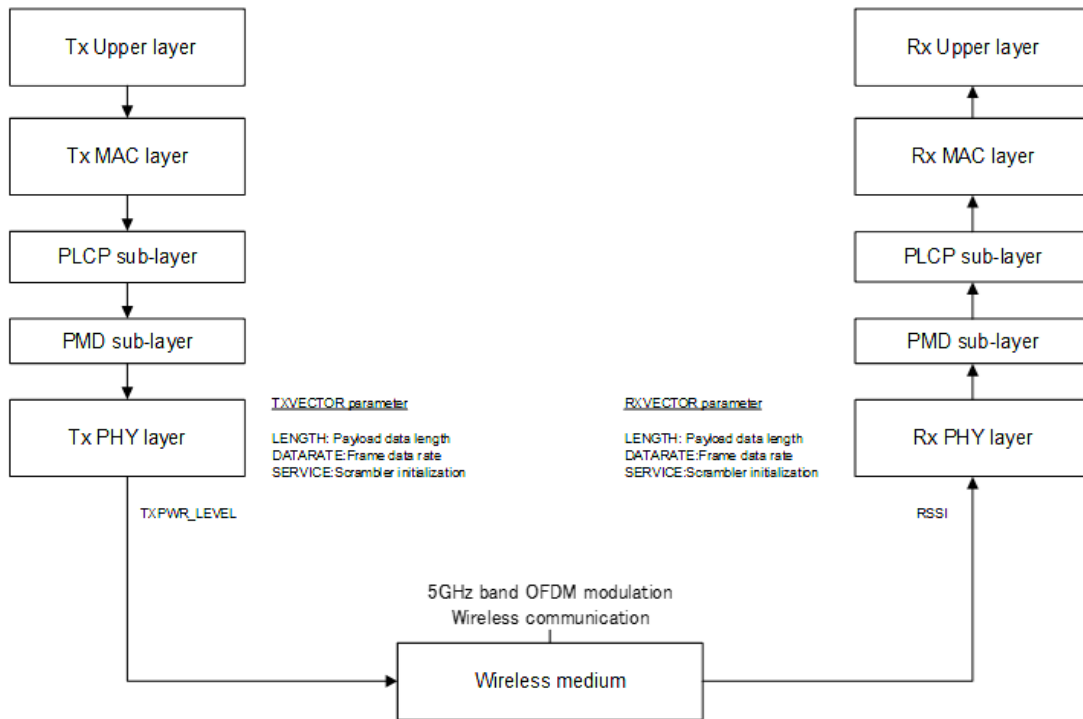

Figure 5. IEEE 802.11a OFDM Layer Configuration

3.4. The OFDM modulation and demodulation with sub-channel orthogonal basis

According to IEEE 802.11a-1999 (R2003) [25], the baseband OFDM modulation can be identified from (4) as follows:

$$r_{DATA,n}(t) = w_{TSYM}(t) \left(\sum_{k=0}^{N_{SD}-1} d_{k,n} \cdot e^{j2\pi \cdot M(k) \cdot \Delta F(t-T_{GI})} + p_{n+1} \sum_{l=-\frac{N_{ST}}{2}}^{\frac{N_{ST}}{2}} P_l \cdot e^{j2\pi \cdot l \cdot \Delta F(t-T_{GI})} \right) \quad (4)$$

where the signal points on the Imaginary and Quadrature complex planes are depicted in Figure 5. Typically, the subcarrier signals of an orthonormal base ($\{e^{j2\pi l \Delta F t}\}$) are mapped according to Fourier transform process. Also, the symbol length is limited by the window function with roll-off, as shown in (2).

4. THE PROPOSED OFDM SYNCHRONIZATION SYSTEM DESIGN USING THE WAVELET TRANSFORM

In this section, given that the symbol signal is limited to a finite time by a window function (rectangular waveform with roll-off characteristics), we design an OFDM Synchronization Model corresponding to a feasible and efficient Timing Recovery System for the symbol rate detection using wavelet transform in which the window function is equalized to compensate for waveform distortion due to the propagation path characteristics.

4.1. Timing recovery system (TRS)

OFDM systems use symbol orthogonality between subcarriers to multiplex symbol rate data and separates a symbol rate clock component that separates symbol and its rate clock component from a received frame. However, the orthogonality of the subcarrier signal can be lost by the distortion of the symbol signal's window function (rectangular waveform with roll-off characteristic) due to the symbol propagation path characteristics. A symbol signal consisting of multiplexed subcarriers can be realized by detecting discontinuities between adjacent symbols of OFDM signals. To extract the symbol rate clock, the demodulation of a symbol is necessary by sampling the symbol with a clock obtained by multiplying the reproduced symbol rate clock by the number of subcarriers (N_0), and performing Fourier transform.

Typically, we propose the OFDM TRS via the following configuration steps:

- Uses the waveform equalization processing to maintain orthogonality between subcarriers;
- Recover symbol rate clock by detecting discontinuity of adjacent symbols of OFDM signals;
- Regenerate the sampling clock multiplied by the symbol clock;
- Track the sampling timing using the pilot signal extraction by multiple resolutions.

Also, in this research, to realize a feasible and practical TRS, we adopt a method which is suitable for hardware implementation from the discrete wavelet complex transform as defined in [26]. The detail of the hardware implementation will be addressed in another paper.

4.2. The OFDM transceiver synchronization model for symbol clock rate detection

In the analog signal processing model, the random noise is superimposed on the signal of the propagation path with a finite length transmission signal having an attenuation of signal power, in which signal filtering corresponds to the transmission symbol characteristics. The reception system amplifies the power of the received signal affected by the propagation path and compensates for the distortion of the signal by equalizing the propagation path characteristics so that the influence of the received signal of different delay times and random superimposed noise can be reduced. Typically, the receiving system detects the frequency and phase of the transmission clock from the reception signal to recover the encoded signal synchronized with the transmission clock and includes an analog-to-digital conversion and a function of establishing synchronization with the reception signal. It is represented by a discrete-time signal processing model that describes the transmission, propagation path, and reception system introduces a signal space model by functional analysis.

In OFDM, a signal in the Hilbert space acts as a linear space in which an inner product operation is defined. OFDM can represent symbol rate signals in a series expansion with subcarrier signals as orthogonal bases. The coefficient value of series expansion constitutes transmission data. A symbol rate signal of finite length by series expansion representation by an orthonormal basis is characterized so that transmission data is reproduced by discrete Fourier transform. Synchronization in an OFDM receiver is conducted by a TRS, which detects the correct sampling timing from a reception signal converted to an analog signal by an ADC and synchronizes the clock of the receiver with the reception signal. In the proposed OFDM system, a local oscillation frequency (f_{lorx}) upconverts to the center frequency of the wireless transmission signal, whereas a local oscillation frequency (f_{lorx}) downconverts the wireless reception signal, and these subcarrier frequencies are synchronized between the Transmitter (T_x) and Receiver (R_x). By synchronizing the sampling clocks of T_x and R_x , the sampling numbers per symbol rate are synchronized.

An OFDM system detects symbols containing subcarriers and synchronizes the symbol rate with T_x and R_x . The conventional symbol rate detection synchronizes (corresponding) to the symbol timing of R_x by the timing detection of the center symbol by the autocorrelation function of the pilot signal from the periodical signal included in the symbol. Overall, the proposed synchronization framework in OFDM using wavelet transform to detect and configure the Symbol clock by converting the baseband I/Q signal to real signal, then decompose the signal and detect the symbol clock rate via the threshold-based decision-making process. Finally, the system reconstructs signal and analyzes the symbol clock components to realize an efficient and feasible OFDM Transceiver Synchronization Model using wavelet transform.

5. RESULTS, EVALUATIONS, AND DISCUSSION

5.1. The simulation scenario and key parameters

We evaluate the proposed OFDM transmission and reception synchronization model with wavelet by simulation, as shown in Figure 1. Typically, we use wavelet signal processing, which is added to the OFDM synchronization model provided by Mathworks Matlab. For the received signal in which noise is superimposed, the effect of removing unnecessary frequency components for noise components and OFDM complex is verified by the signal decomposition, frequency selection, and signal combination by the wavelet transform with Additive white Gaussian noise (AWGN) as defined in Figure 6. Wavelet is modeled by Morlet

wavelet in Matlab because this kind of wavelet is suitable for orthogonal signals, and the effect of orthogonal OFDM is easy to be observed in Morlet wavelet. The key parameters for system evaluation in Matlab are summarized in Table 1.

5.2. Results and discussion

Figure 7 illustrates the bit error rate (BER) performance of the proposed system in AWGN channel under various values of frequency offset between transmitter and receiver, which ranges from -20 kHz to 20 kHz. We observe that for all the frequency offset values, the wavelet transform performance gains a better performance for symbol synchronization in terms of BER when the E_b/N_0 (energy per bit to noise power spectral density ratio) value is increased. Also, when the frequency offset is -20 kHz, the frame error rate performance is worst compared to other frequencies offset value. Besides, all the positive frequency offset reaches the satisfactory performance of BER for wireless communication when the value of E_b/N_0 is not less than 13 dB, and among the positive frequency offset values, +20 kHz showed the best performance after 10 dB. We then show that the proposed OFDM synchronization model using wavelet can efficiently recover symbols in a wide range of frequency offset values.

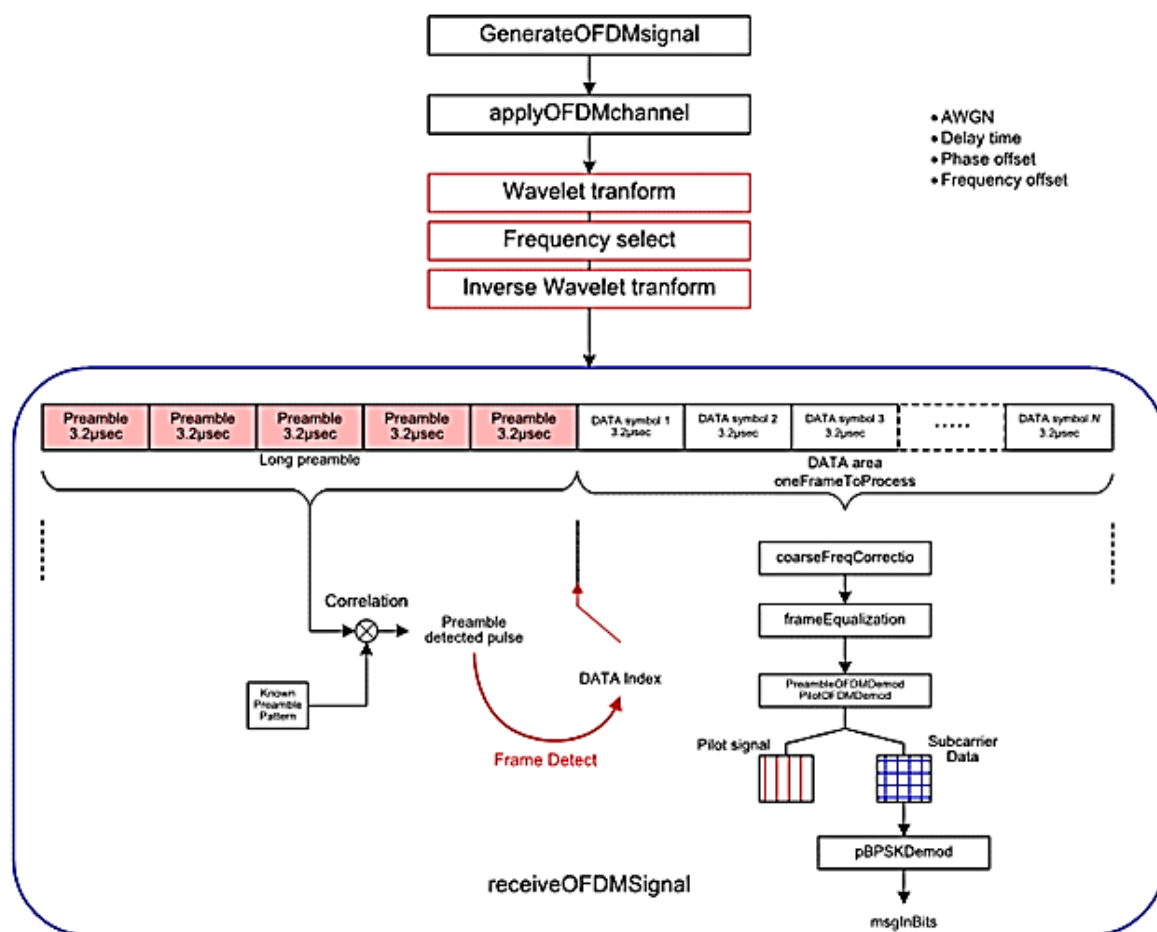

Figure 6. Effects of selecting different switching under dynamic condition

Table 1. Key parameters for system evaluation in Matlab

Variable	Type
Sampling frequency (Hz)	20 GHz
Sampling period (sec)	$5 * 10^{-8} sec$
Number of Frames per iteration	10
Number of iterations	100
Channel type	AWGN

In Figure 8, we present the frame error rate performance of the proposed system based on the IEEE 802.11a standard in the AWGN channel. For all the frequency offset values, the frame error rate performance is steady when E_bN_0 is less than 8 dB. Moreover, the non-positive offset frequencies (-20 kHz, -10 kHz, and 0 kHz) can gain a lower BER performance compared to that of positive offset frequency, especially when E_bN_0 value is greater than 8 dB.

Overall, the evaluation results show that the proposed OFDM synchronization model with TRS using wavelet transform (conformed to the IEEE 802.11 standard) can help to reduce the noise and detect the symbol preamble to realize an efficient OFDM synchronization system through the novel symbol clock rate detection mechanism. These results also suggest that by extracting channel distortion and frequency offset, the proposed OFDM signal space model construction method with the orthogonal basis using wavelet analysis can be expanded to a wide range of communication systems.

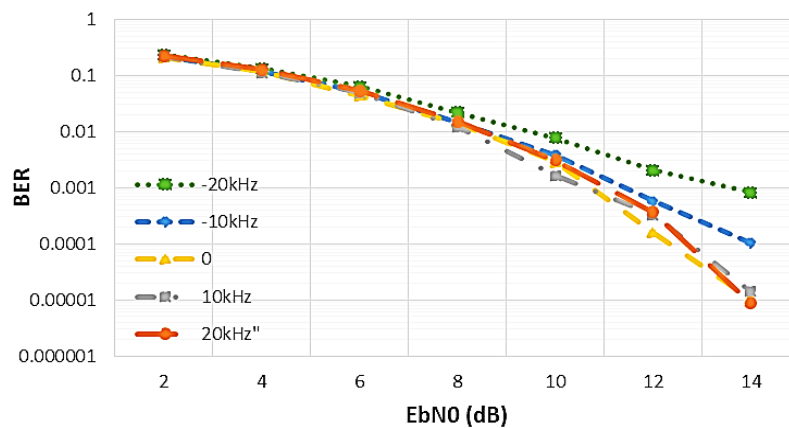

Figure 7. Bit error rate performance of the proposed wavelet transform with various values of frequency offset in AWGN

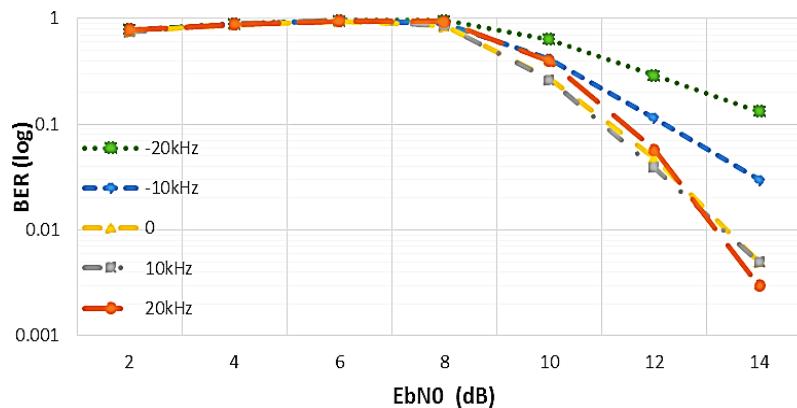

Figure 8. Frame error rate performance of the proposed wavelet transform with various values of frequency offset in AWGN

6. CONCLUSION AND FUTURE WORK

As in OFDM, it is necessary to synchronize to the symbol rate, the local frequency conversion, and the sampling timing, in this paper, we propose a method to establish OFDM symbol rate synchronization by projecting received signal onto complex signal space of orthogonal bases of receiver clock system based on wavelet signal analysis and recovery. Symbol rate timing is a method of extracting a clock wave-form synchronized with a symbol rate through the de-noise process with a multiresolution analysis that detects discontinuities between symbols. We propose a novel TRS methodology focusing on frame synchronization and clock frequency offset recovery that is based on a signal projection by asynchronous oversampling, instead of the feedback loop control as in the conventional symbol timing recovery methods.

The communication system generates a transmission signal by encoding, modulation, symbol generation, and frequency conversion. The theoretical model of the transmission signal is conducted until the encoded discrete signal is synchronized with the transmission clock and converted to an analog signal. The transmission analog signal requires an analog signal processing model that diminishes signal discontinuities and transmission power to match the signal bandwidth and the communication propagation path. Typically, we build the sampling model from the digital-to-analog conversion processing (DAC) of transmitter and analog-to-digital signal processing (ADC) of the receiver, according to the theory of reproduction, orthogonal transmission basis by performing signal projection at the receiver side. The difference between the bases is calculated from the offset, which is the difference between the phase and the frequency to represent the synchronization system between transmitter and receiver in which a receiver synchronizes with a received signal received from a transmitter via a communication channel, and the transmitted signal is correctly regenerated. In this way, the receiving system represents an infinite-dimensional analog signal and is realized as an approximated finite-dimensional signal using a sampling method by performing projection operations for synchronization.

For future work, we will present the theory model, which can minimize the inter-symbol interference (ISI) due to discontinuities between symbol rate signals, synchronization, and demodulation of subcarrier signals in the symbol. We also have the plan to build optimal receiver architecture for hardware implementation using a mathematical model to enhance the feasibility of the proposed OFDM wireless communication network. Also, an OFDM signal space model based on wavelet analysis with a new algorithm for extracting frequency offset and equalization distortion is needed to further shorten the synchronization pull-in time and improve the stability against disturbance. Besides, the Doppler effect will be considered for the potential OFDM synchronization design, which applies to the mobile receivers.

ACKNOWLEDGEMENTS

This research was partly funded by Waseda University Grant for Special Research Projects grant number 2019C-174. The study is also partially supported by Fujitsu-Waseda Digital Annealer FWDA Research Project (Joint Research between Waseda University and Fujitsu R&D Lab.) conducting at Fujitsu Co-Creation Research Laboratory at Waseda University.

REFERENCES

- [1] Q. N. Nguyen, M. Arifuzzaman, K. Yu and T. Sato, "A Context-Aware Green Information-Centric Networking Model for Future Wireless Communications," *IEEE Access*, vol. 6, pp. 22804-22816, 2018.
- [2] Q. N. Nguyen, K. Yu, T. Sato and M. Arifuzzaman, "A game-theoretical green networking approach for information-centric networks," *IEEE Conference on Standards for Communications and Networking (CSCN)*, pp. 132-137, Helsinki, 2017.
- [3] Q. N. Nguyen, "A Study on the Context-Aware Green Information-Centric Networking Model for Future Wireless Communications", *Dissertation*, Waseda University, Tokyo, Japan, March 2019.
- [4] Nguyen, Q.N., Liu, J., Pan, Z., Benkacem, I., Tsuda, T., Taleb, T., Shimamoto, S., Sato, T., "PPCS, A Progressive Popularity-Aware Caching Scheme for Edge-Based Cache Redundancy Avoidance in Information-Centric Networks." *Sensors*, vol. 19, no. 3, pp. 694, 2019.
- [5] Q. N. Nguyen et al., "Adaptive Caching for Beneficial Content Distribution in Information-Centric Networking," *2020 International Conference on Information Networking (ICOIN)*, Barcelona, Spain, pp. 535-540, 2020.
- [6] Sukjaimuk, R., Nguyen, Q.N., Sato, T., "A Smart Congestion Control Mechanism for the Green IoT Sensor-Enabled Information-Centric Networking." *Sensors* 2018, 18, 2889.
- [7] Safitri C., Yamada Y., Baharun S., Goudarzi S., Ngoc Nguyen Q., Yu K., Sato T., "An Intelligent Content Prefix Classification Approach for Quality of Service Optimization in Information-Centric Networking." *Future Internet*, vol. 10, no. 33, 2018.
- [8] I. Benkacem, M. Bagaa, T. Taleb, Q. Nguyen, T. Toshitaka and T. Sato, "Integrated ICN and CDN Slice as a Service," *2018 IEEE Global Communications Conference (GLOBECOM)*, Abu Dhabi, United Arab Emirates, pp. 1-7, 2018.
- [9] D. Zhang, Y. Liu, Z. Ding, Z. Zhou, A. Nallanathan and T. Sato, "Performance Analysis of Non-Regenerative Massive-MIMO-NOMA Relay Systems for 5G," *IEEE Transactions on Communications*, vol. 65, no. 11, pp. 4777-4790, Nov. 2017.
- [10] Y. Tao, L. Liu, S. Liu and Z. Zhang, "A survey: Several technologies of non-orthogonal transmission for 5G," *China Communications*, vol. 12, no. 10, pp. 1-15, Oct. 2015. DOI: 10.1109/CC.2015.7315054
- [11] S. M. Saad, H. M. Hamed and A. F. Shalash, "Timing recovery in DVB-T2 using multi-rate farrow structure," *IEEE International Conference on Electronics, Circuits, and Systems (ICECS)*, pp. 229-232, Cairo, 2015.
- [12] S. S. Shin, Y. G. Jeon, J. G. Oh and J. T. Kim, "A study of timing and frequency synchronization scheme in VSB systems for terrestrial 3D HDTV broadcasting," *IEEE International Conference on Consumer Electronics (ICCE)*, pp. 287-288, Las Vegas, NV, 2012.
- [13] Y. Huang, X. Zhang and L. Xi, "Modified synchronization scheme for coherent optical OFDM systems," *IEEE/OSA Journal of Optical Communications and Networking*, vol. 5, no. 6, pp. 584-592, June 2013.

- [14] M. Morelli and M. Moretti, "A Robust Maximum Likelihood Scheme for PSS Detection and Integer Frequency Offset Recovery in LTE Systems," *IEEE Transactions on Wireless Communications*, vol. 15, no. 2, pp. 1353-1363, Feb 2016.
- [15] R. Fan, Y. J. Yu and Y. L. Guan, "Generalization of Orthogonal Frequency Division Multiplexing With Index Modulation," in *IEEE Transactions on Wireless Communications*, vol. 14, no. 10, pp. 5350-5359, Oct. 2015.
- [16] Alhasani, M.M., Nguyen, Q.N., Ohta, G.-I., Sato, T., "A Novel Four Single-Sideband M-QAM Modulation Scheme Using a Shadow Equalizer for MIMO System Toward 5G Communications," *Sensors*, vol. 19, pp. 1944, 2019
- [17] A. M. Mustafa, Q. N. Nguyen, T. Sato and G. Ohta, "Four Single-Sideband M-QAM Modulation using Soft Input Soft Output Equalizer over OFDM," *International Telecommunication Networks and Applications Conference (ITNAC)*, Sydney, NSW, pp. 1-6, 2018.
- [18] A. Ghaith, R. Hatoum, H. Mrad and A. Alaeddine, "Performance analysis of the Wavelet-OFDM new scheme in AWGN channel," *Third International Conference on Communications and Information Technology (ICCIT)*, pp. 225-229, Beirut, 2013. DOI: 10.1109/ICCITechnology.2013.6579554
- [19] Volkan Kumbasar, Oğuz Kucur, "Performance comparison of wavelet based and conventional OFDM systems in multipath Rayleigh fading channels," *Digital Signal Processing*, vol. 22, no. 5, Pp. 841-846, 2012. ISSN 1051-2004
- [20] D. Karamehmedovic, M. K. Lakshmanan and H. Nikookar, "Performance of Wavelet Packet Modulation and OFDM in the presence of carrier frequency and phase noise," *European Conference on Wireless Technology*, Amsterdam, pp. 166-169, 2018.
- [21] X. Q. Jin and J. M. Tang, "Optical OFDM Synchronization With Symbol Timing Offset and Sampling Clock Offset Compensation in Real-Time IMDD Systems," in *IEEE Photonics Journal*, vol. 3, no. 2, pp. 187-196, April 2011.
- [22] Y. Huang, X. Zhang and L. Xi, "Modified synchronization scheme for coherent optical OFDM systems," *IEEE/OSA Journal of Optical Communications and Networking*, vol. 5, no. 6, pp. 584-592, June 2013.
- [23] D. Karamehmedovic, M. K. Lakshmanan and H. Nikookar, "Performance of Wavelet Packet Modulation and OFDM in the presence of carrier frequency and phase noise," *European Conference on Wireless Technology*, pp. 166-169, Amsterdam, 2008.
- [24] K. Abdullah and Z. M. Hussain, "Performance of Fourier-based and wavelet-based OFDM for DVB-T systems," *Australasian Telecommunication Networks and Applications Conference*, pp. 475-479, Christchurch, 2007.
- [25] IEEE 802.11a-1999 (R2003).
- [26] F. C. A. Fernandes, R. L. C. van Spaendonck and C. S. Burrus, "A new framework for complex wavelet transforms," *IEEE Transactions on Signal Processing*, vol. 51, no. 7, pp. 1825-1837, July 2003.

BIOGRAPHIES OF AUTHORS



Masaru Sawada received a Bachelor Degree in Maths, Waseda University, Tokyo, Japan in 1986. He joined the design team of DSP core block. He worked there as an LSI designer who designed architecture and core logic from 1986 to 2000. He researched signal processing architecture for hard disk drives (HDD) and developed a full digital timing recovery loop and auto equalizer in FUJITSU LABORATORIES LIMITED from 2001 to 2004. He did research on a wideband low noise amplifier (LNA) and designed architecture of Fractional-N Phase-Locked Loop (PLL) and circuits of the PLL from 2005 to 2006. He was the project manager of technology development division, RF technology department, FUJITSU MICROELECTRONICS SOLUTIONS LIMITED and did research on low power circuits for RF receivers and optimization methods from 2006 to 2013. He also joined cooperative research on low-power analog circuits with the research institute of electrical communication, TOHOKU University, from October 2011 to March 2012. Currently, he is a Ph.D. Candidate at the Faculty of Science and Engineering, Waseda University.



Quang Ngoc Nguyen received the B.Eng. Degree in Information Technology, Honor Computer Science Program conducted in English from Posts and Telecommunications Institute of Technology, Hanoi, Vietnam in 2012, and became one of the youngest Faculty members of the Institute. He received an M.Sc. degree and Ph.D. degree from Waseda University, Tokyo, Japan in 2015 and 2019, respectively. Currently, he is an Asst. Professor with Faculty of Science and Engineering, Waseda University where he was a Research Associate since 2018. He served as a Session Chair at IEEE ICC 2017 and a co-organizer as well as a conference chair of APSCIT (Asia Pacific Society of Computing and Information Technology) Annual Meeting 2019. His research interests include Future Internet design, Green Networking, wireless communication systems, sensor network, IoT, and Game Theory. He was the sole Awardee of Asia Special Scholarship, Waseda University for Fall 2013 admission to GITS, Waseda University. He was also a recipient of young author recognition awarded by the International Telecommunication Union (ITU) for young first-author of highly potential research under 30 years old.



Mohammed Mustafa Alhasani is from Saudi Arabia and currently a Ph.D. student in Communication Engineering at the Department of Communications and Computer Engineering, Faculty of Science and Engineering, Waseda University. He is a graduate of Waseda University, where he received an M.A. degree in Communication Engineering. Before that, he received the B.Sc. degree in Electrical Engineering from Umm AL-Qura University, Mecca, Saudi Arabia. His research interests include 5G and beyond network, wireless communications, Single SideBand (SSB), and increasing wireless capacity.



Cutifa Safitri received her B.CS (Honored) and M. IT from International Islamic University Malaysia, Selangor, Malaysia in 2012 and 2014, respectively. She received her Ph.D. degree in Electronic System Engineering from Malaysia-Japan International Institute of Technology, Universiti Teknologi Malaysia, in 2019. Currently, she is a Senior Lecturer in the Faculty of Computing at President University.



Takuro Sato received the B.E. and Ph. D. degrees in electronics engineering from Niigata University, Niigata, Japan, in 1973 and 1993, respectively. He joined the Research and Development Laboratories, OKI Electric Industry Co., Ltd., Tokyo, Japan, in 1973, where he was a Senior Research Manager and Research Director with Communication Systems Laboratory. He joined the Niigata Institute of Technology from 1995 as a Professor. In 2004, he joined GITS, Waseda University, Tokyo, as a professor and currently serving as the Dean. He has developed a wideband CDMA system for personal communication systems and joined the PCS standardization committee in the USA and Japan. His contributions are mainly in high-speed cellular modem standardization for ITU, 2.4GHz PCS for ITA and WLAN technology (IEEE 802.11), and so on. He has authored 11 books and more than 200 papers. His current research interests include next wireless communications, ICN technology, ICT in the smart grid, and their global standardizations. He is a fellow of IEEE and IEICE.