

Readiness measurement of IT implementation in Higher Education Institutions in Indonesia

Mohamad Irfan¹, Syopiansyah Jaya Putra²

¹Department of Informatics, Faculty of Sains and Technology, UIN Sunan Gunung Djati Bandung, Indonesia

²Department of Information System, Syarif Hidayatullah State Islamic University Jakarta, Indonesia

¹Department of ICT, Asia E University Malaysia, Malaysia

Article Info

Article history:

Received Aug 1, 2019

Revised Jan 6, 2020

Accepted Feb 19, 2020

Keywords:

ITIR

Pilot study

PLS-SEM

Validation model

ABSTRACT

This article elaborates the result of the Pilot Study which is related to IT implementation factors at the Higher Education Institution (HEI), a pilot study is used to validate quantitative readiness model of IT implementation. The main objective of this study is examining the factors that influence the readiness of IT implementation in HEI. This study attempts to analyze IT Content factors, Institutional Context, People, Process, Technology, Service Quality and IT Implementation Readiness (ITIR). The sample of data was taken from 150 HEIs throughout Indonesia which was then processed in statistical techniques through PLS-SEM method. The research finding shows that 9 of the 14 hypotheses used as ITIR model construct have a very significant influence on IT implementation on HEI, so that this finding can provide a comprehensive contribution to the literature of ITIR model development.

This is an open access article under the [CC BY-SA](https://creativecommons.org/licenses/by-sa/4.0/) license.



Corresponding Author:

Mohamad Irfan,

Department of Informatics, Faculty of Sains and Technology,

UIN Sunan Gunung Djati Bandung

Jl. A.H. Nasution No.105, Cipadung, Kec. Cibiru, Kota Bandung, Jawa Barat 40614, Indonesia.

Email: irfan.bahaf@uinsgd.ac.id

1. INTRODUCTION

Along with the rapid development of information technology nowadays, it is certain that IT is involved in all fields, including higher education institution [1]. IT does not only benefit the things that directly utilize the potential of technology, but also encourage the emergence of new innovations in doing work/activities [2]. One task that belongs to high education is the utilization of IT development in supporting the provision of high quality services of high education which is affordable for the people who need education [3]. There are two important ways which can lead us to the purpose of IT development. First, high education needs to understand the roles that IT can do in supporting higher education processes and the ways that IT can perform that roles. Second, understanding the way to build a conducive environment so that IT can provide optimal support [4]–[6].

John Ward and Joe Peppard stated that there are three main objectives of the application of SI/IT in an organization. First of all is improving work efficiency by automating various processes that manage information. Secondly, improving management effectiveness by fulfilling information needs for decision making. Thirdly, improving competitiveness or improving an organization's competitive advantage by changing the style and way of doing business. The fact that this application is not in line with expectations, the value of failure reaches 18%, the implementation of IT problems is 55% and successful IT

implementation is 27% [7]. The result of the study of the utilization of readiness for IT implementation have a significant impact on the success of IT project on HEI [8], [9].

This article constitutes a series of doctoral research that covers literature review, pretest and pilot study. The objective of pilot study is to validate the model of IT Implementation Readiness using quantitative method. Moreover, this study is intended to reveal the status of IT implementation readiness in HEI and to ascertain the factors that affect IT implementation readiness. In order to ascertain the above objectives, there was applied a statistical method called partial structural-equation modeling (PLS-SEM) with SmartPLS 2.0, which is considered to be appropriate for this study. The total responses of respondents ($n = 180$) were taken from some HEI respondents in Indonesia. 14 hypotheses as shown in Figure 1 were then tested. The results show that 8 hypotheses were rejected after the structural model assessment. The purpose of this study is exploring the factors that influence ITIR organizations.

This study covers five sections. The first part of this article is introduction, followed by the literature review which reveal the modeling and pilot study. Meanwhile the third part is the research method applied in the pilot study, which is followed by the research findings and the data analysis. The following part is discussion and data presentation, that ends with the research conclusion

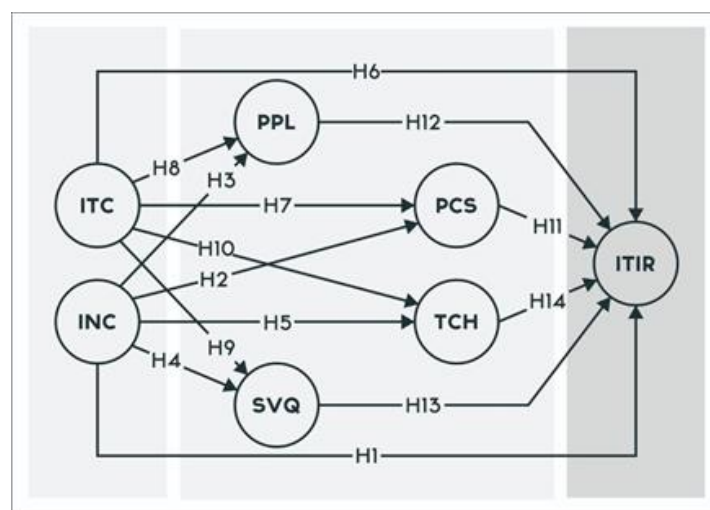

Figure 1. The research model

2. RESEARCH METHOD

2.1. Research model

As stated by Matti Synco, the factors that have an influence on the implementation of ICT in Higher Education (HEI) are divided into four groups, namely global challenge, benefits of technology; pedagogical factors; barrier and limitation to ICT application; and political issues. Moreover, Alemayehu Molla and Paul S. Licker highlighted the role and perception of organization based on the perception of e-readiness organization (POER) and perception of e-readiness environment (PEER), which included innovative, managerial, organizational, and environmental characteristics as determinant factors of IT adoption and implementation in HEI [10]. In this regard, the framework of e-readiness model which (1) can be reused consists of components that are not bound to a particular moment in time, and (2) includes all relevant variables [11], the variables include people, process and technology [12]. This indicator is easy to measure and has relevant factors for IT implementation in HEI [13], while e-readiness has become a core feature of international socio-economic development for its ability to change society movement from traditional relation to a more modern way of thinking or dealing with health, education and production [14], so HEI is able to have a smart campus with IT utilization indicators on HEI that are used in optimal and massive manners [15]. Another factor that influences the success of IT implementation in HEI is the quality of IT services adjusted to Institutional Context [16].

The modelling in this study is built by combining, adapting and adopting existing models using Input-Process-Output logic to produce a new model as shown in Figures 1 and 2. Through the combination and adoption, 42 indicators were used to measure IT implementation readiness in HEI as shown in Table 1. Previously there were 46 indicators interconnected, but their number was simplified into 42 indicators according to the recommendations of the conducted studies that aim to perform indicator validation, pre-test

and confirmation using quantitative method. In this study, an inductive-quantitative approach is conducted to validate the proposed model through survey results.

Furthermore, this quantitative research is intended to validate the model, both logically and empirically. Logical validation is done when the model is logically analyzed in accordance with the content and aspects expressed, while empirical analysis works when an instrument can reveal all data captured by the five senses existing in the objects of the research field [17, 18]. In addition, this quantitative research is concerned with the degree of objectivity, consistency and stability of data or findings that are related to the developed model, regarding the degree of many people agreement towards data. Based on the obtained data, the point from this validation study is that the stakeholders participating in this study revised the first model by repositioning the variables so that the number of relationships between variables within the model increased. Meanwhile, within the other improvement, the researcher also reformulated the conceptual framework by accommodating the TESCA model as an additional dimension from the framework. In graphical illustration, Figure 3 shows the model a conceptual framework.

Table 1. Reference of Indicators

Code	Indicators	References
ITC1	Timeliness	[19],[20],[21],[11]
ITC2	Completeness	
ITC3	Consistency	
ITC4	Relevance	
ITC5	Technology Complexity	
ITC6	Information Quality	
ITC7	System Quality	
ITC8	Perceived Usefulness	
ITC9	Perceived Ease of Use	
INC1	Institutional Policies	[19],[22],[10],[23]
INC2	Management Involvement	
INC3	Infrastructure Availability	
INC4	External Environments	
INC5	Legal Environment	
PPL1	Workforce Capability	[12],[24],[25]
PPL2	Leadership	
PPL3	Competency	
PPL4	Resources	
PPL5	Change Management	
PPL6	Resources and Cultural Infrastructure	
PCS1	Culture	[12],[24],[25]
PCS2	Governance	
PCS3	Awareness	
PCS4	Strategy	
PCS5	Management Commitment	
TCH1	Infrastructure	[12],[24],[25]
TCH2	Security	
TCH3	Networking	
TCH4	Data	
TCH5	Telecommunication	
SVQ1	Responsiveness	[26],[16],[14]
SVQ2	Availability	
SVQ3	Functionality	
SVQ4	Extension	
SVQ5	Reliability	
SVQ6	Efficiency	
SVQ7	Effectiveness	
ITIR1	Technology Management	[15], [27]
ITIR2	IT skills	
ITIR3	IT Partnership	
ITIR4	Quality Improvement	
ITIR5	IT acquaintance	

Processional and Causal Dimensions				References							
Input	→	Process	→	Output	(Davis, 1998)						
Organization Context	→		→	System Adaptation	(Molla & Licker, 2005)						
		Information	→	Infrastructure	→	Human Capital	→	System Readiness	(Tarvid, 2008)		
Institutional Context	→	Orga. Strategy	→	Infrastructure	→	HEAM	(Kashorda & Waema, 2011)				
Environment	→	Technology Transfer	→	Information Quality			(Dos Reis & Do Carmo Duarte Freitas, 2014)				
				TESCA			(Marcel, 2016)				
				Service Quality	→	E-Readiness Accession	(Kiula, Waiganjo, & Kihoro, 2017)				
IT Content	→	Institutional Context	→	Service Quality	→	Technology	→	People	→	ITIR	(Mohamad Irfan, Putra, & Alam, 2018)

Figure 2. The critical study of the processional and causal model

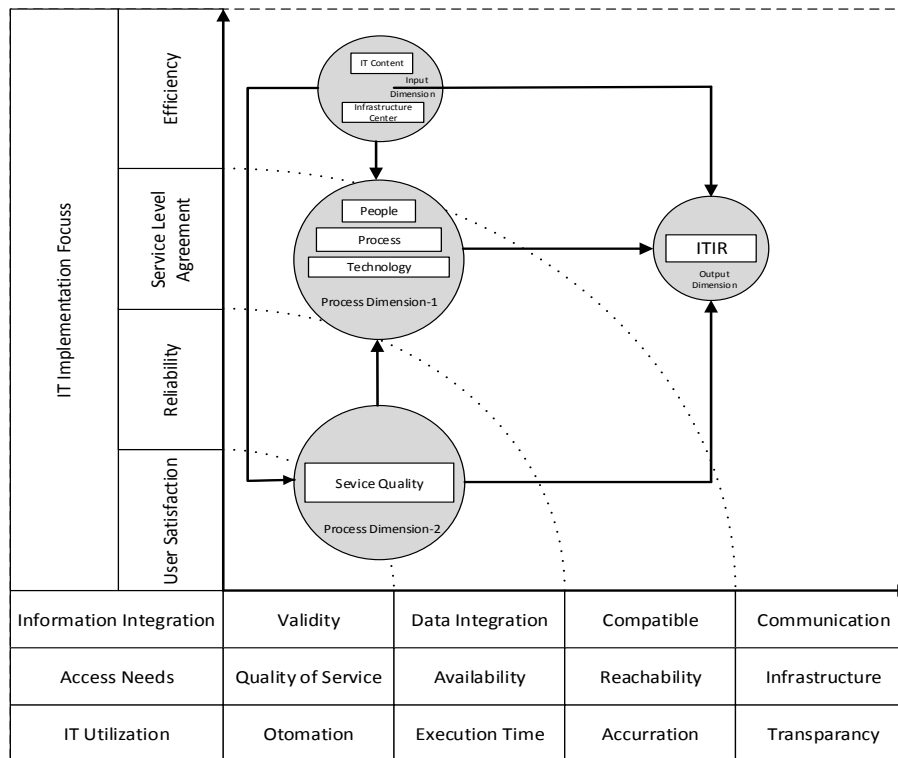

Figure 3. Conceptual framework ITIR

2.2. Research procedure

Figure 4 shows two primary stages of research, namely, preliminary study and pilot study. This study develops a conceptual framework [28] and a research model [8], and validates the model quantitatively. In particular, this pilot study was conducted based on the recommendations from previous studies in order to validate model and variable which are developed quantitatively.

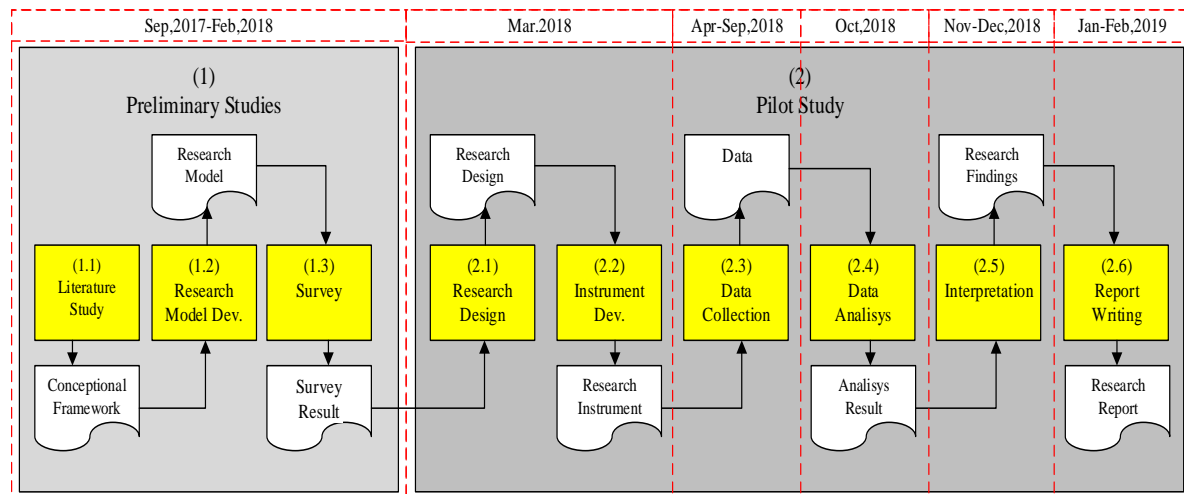

Figure 4. The research procedure

2.3. Population, sample and data collection procedure

The population in this pilot study is stakeholders of IT utilization in higher education institutions in Indonesia that cover top managers, middle managers, IT unit managers, and IT staff. The types of stakeholders chosen refer to key informant aspects [29, 30]. 250 data were obtained from institutions and purposive sampling techniques from universities that have implemented IT, by selecting 160 (64%) respondents. The biggest number of respondents (51%) are university graduates and 68% of them have experiences less than ten years in managing IT at HEI. Moreover, the highest percentage of their job positions belongs to IT staff members (50%). In the data collection procedure, electronic questionnaires are sent to 300 email addresses and messages broadcast through social media.

2.4. Research instruments and data analysis

The instrument of this study is a survey questionnaire using a five-point Likert scale ranging from 'strongly disagree' to 'strongly agree' [31, 32]. In data analysis process, descriptive analysis was conducted to produce demographic information to answer the objectives of the first study and clarify the next inferential findings. Meanwhile, inferential mode is done using PLS-SEM with SmartPLS 2.0 to assess measurement and structural models. Statistical software is used due to strong exploration and prediction with small size of sample sizes [33, 34]. The assessment of measurement model covers indicator reliability, internal consistency reliability, convergent validity, and evaluation of discriminant validity to test the external model. In addition, the assessment of structural model consists of path coefficient (β), determinant coefficient (R^2), t-test, effect size (f^2), predictive relevance (Q^2), and relative impact (q^2) checks to evaluate the inside factor.

3. THE ANALYSIS RESULT

3.1. The result of the descriptive analysis

The information of the survey result is presented in Table 2, and the analysis results illustrate that 61% of respondents stated that IT implementation in HEI aims to meet operational requirements, 17% said to fulfill managerial requirements and 22% revealed for strategic requirements. The other result stated that 85% of HEI have IT implementation strategic planning. The analysis result of IT implementation architecture ownership in HEI reached 59%, while the analysis results of IT implementation roadmap ownership reached 52%.

Table 2. The IT implementation profile

Measure	Item	%
Goal IT implementation	Operational requirements	61%
	Managerial requirements	17%
	Strategic requirements	22%
Ownership of Strategic Plans for IT Implementation	Available	85%
	Not Available	15%
Ownership of Architecture IT Implementation	Available	59%
	Not Available	41%
Ownership of Roadmap IT Implementation	Available	52%
	Not Available	48%

3.2. The result of the inferential analysis table

Inferential statistics use a random sample of data taken from a population to describe and make conclusions about a population. The results of the inferential analysis are presented in Table 3. Preliminary Discriminant Validity is testing performed in two ways, namely by looking at the value of cross loading or cross loading Fornell-Lacker's, by comparing the value of the root of AVE (top values in the table) where the value must be greater than the correlation between the constructs to construct another. Information about Preliminary Discriminant Validity is presented in Table 4.

Table 3. Results of the measurement model assessments

Ind	OL	Cross Loading							AVE	CR		
		INC	ITC	ITIR	PCS	PPL	SVQ	TCH				
INC1	0.943	0.943	0.604	0.805	0.807	0.871	0.879	0.823	0.885	0.959		
INC2	0.951	0.951	0.596	0.797	0.788	0.867	0.851	0.861				
INC3*												
INC4	0.929	0.929	0.584	0.766	0.801	0.819	0.818	0.826	0.867	0.979		
ITC1	0.919	0.602	0.919	0.586	0.570	0.605	0.605	0.630				
ITC2	0.948	0.578	0.948	0.609	0.565	0.574	0.577	0.591				
ITC3	0.899	0.546	0.899	0.524	0.486	0.539	0.529	0.528				
ITC4	0.924	0.551	0.924	0.588	0.553	0.564	0.595	0.576				
ITC5	0.963	0.606	0.963	0.640	0.555	0.604	0.593	0.633				
ITC6	0.943	0.612	0.943	0.613	0.518	0.588	0.588	0.602				
ITC7	0.922	0.622	0.922	0.632	0.538	0.585	0.595	0.607				
ITIR1	0.933	0.821	0.604	0.933	0.840	0.887	0.882	0.846				
ITIR2	0.885	0.682	0.567	0.885	0.752	0.761	0.798	0.789	0.862	0.969		
ITIR3	0.947	0.775	0.643	0.947	0.811	0.814	0.808	0.812				
ITIR4	0.947	0.811	0.605	0.947	0.821	0.850	0.818	0.825				
ITIR5	0.928	0.801	0.572	0.928	0.797	0.832	0.802	0.814				
PCS1	0.896	0.738	0.496	0.756	0.896	0.805	0.759	0.779				
PCS2*									0.830	0.951		
PCS3	0.932	0.799	0.525	0.801	0.932	0.794	0.816	0.823				
PCS4	0.918	0.764	0.522	0.787	0.918	0.797	0.832	0.810				
PCS5	0.899	0.791	0.574	0.816	0.899	0.809	0.786	0.810				
PPL1	0.909	0.804	0.571	0.825	0.820	0.909	0.850	0.853				
PPL2	0.927	0.848	0.589	0.823	0.799	0.927	0.846	0.851			0.854	0.967
PPL3	0.944	0.859	0.550	0.821	0.798	0.944	0.864	0.833				
PPL4	0.906	0.800	0.587	0.824	0.816	0.906	0.806	0.809				
PPL5	0.935	0.872	0.584	0.837	0.828	0.935	0.845	0.870				
SVQ1	0.925	0.803	0.561	0.813	0.794	0.833	0.925	0.832				
SVQ2	0.923	0.815	0.572	0.802	0.830	0.830	0.923	0.825	0.851	0.981		
SVQ3	0.934	0.863	0.556	0.804	0.783	0.846	0.934	0.862				
SVQ4	0.939	0.847	0.589	0.833	0.858	0.853	0.939	0.864				
SVQ5	0.922	0.824	0.561	0.805	0.793	0.820	0.922	0.812				
SVQ6	0.947	0.886	0.620	0.848	0.865	0.884	0.947	0.874				
SVQ7	0.899	0.808	0.559	0.792	0.784	0.841	0.899	0.819				
SVQ8	0.920	0.821	0.625	0.837	0.787	0.849	0.920	0.828				
SVQ9	0.892	0.824	0.559	0.819	0.776	0.810	0.892	0.812				
TCH1	0.924	0.839	0.606	0.844	0.827	0.871	0.814	0.924			0.867	0.970
TCH2	0.929	0.830	0.620	0.793	0.822	0.820	0.801	0.929				
TCH3	0.961	0.871	0.590	0.849	0.855	0.892	0.878	0.961				
TCH4	0.917	0.788	0.578	0.808	0.819	0.831	0.854	0.917				
TCH5	0.925	0.808	0.590	0.804	0.792	0.833	0.877	0.925				

Table 4. Preliminary discriminant validity results

	INC	ITC	ITIR	PCS	PPL	SVQ	TCH
INC	0.911						
ITC	0.641	0.931					
ITIR	0.835	0.644	0.928				
PCS	0.869	0.572	0.854	0.893			
PPL	0.914	0.623	0.894	0.878	0.924		
SVQ	0.909	0.627	0.886	0.877	0.912	0.922	
TCH	0.894	0.641	0.881	0.879	0.913	0.907	0.931

3.2.1. The result of the measurement model assessments

The outlined information from this assessment demonstrates statistically that the external model shows good psychometric properties with two refusal indicators (INC3 and PCS2). This means that the assessment can proceed to the assessment of structural model.

- Testing Individual Item Reliability, that based on testing values on the outer loading, all values have met the threshold value of 0.7, so that there are no indicators deleted, in this case.
- Testing Internal Consistency Reliability, this test is done by looking at the composite reliability (CR) value with a threshold above 0.7. Testing results show that all CR values of all variables meet the requirements and are valid to be used in the research model.
- Convergent Validity Test, this test is done by looking at the average variance extracted (AVE) value with a threshold value of 0.5. The test results in which all AVE values of all variables have met the requirements and are valid for use in the research model.
- Testing Discriminant Validity, it is tested through cross loading comparison analysis with AVE squared value, as follows: there is still found a smaller AVE root value compared to the correlation between other variables, in the next step there are removed some indicators. After several tests, there are 2 (two) deleted indicators, namely: PCS2 and INC3, with each value of 0.846 and 0.858. By removing these two indicators, it is necessary to re-examine internal consistency reliability, composite reliability (CR), convergent validity, and discriminant validity.

3.2.2. The result of the structural model assessments

In the analysis phase of the structural model, there are six stages of testing, namely testing path coefficient (β), coefficient of determination (R^2), t-test using the bootstrapping method, effect size (f^2), predictive relevance (Q^2), and relative impact (q^2).

- Testing path coefficient (β), it is done by looking at a threshold value above 0.1 where the path can be declared to have an influence on the model if the result of the path coefficient test value is above 0.1. The results of the 14 pathways in the research model, 9 of these pathways have significant influence and 5 paths have no significant influence as shown in Figure 5 and Table 5.
- Testing coefficient of determination (R^2), this test is intended to explain the variance of each endogenous variable target with a measurement standard of around 0.670 which is expressed as accurate (A), around 0.333 is expressed as moderate (M) and 0.190 or below indicates weak variant level (L) as shown in Table 5.
- Testing t-test, it is carried out using the bootstrapping method on SmartPLS 3.0, and the received value on the t-test is above 1.96. The test result shows that from a total of 14 hypotheses there are 6 accepted hypotheses and 8 rejected hypotheses as shown in the above table as shown in Figure 5 and Table 5.
- Testing effect size (f^2), this test is done to predict the influence of certain variables. The threshold values are 0.02 for a small effect (k), 0.15 for an intermediate effect (m), and 0.35 for a big effect (b) as shown in Table 5.
- Testing predictive relevance (Q^2), which is conducted through blindfolding method to explain that certain variables used in the model have predictive relationship with other variables in the model with a threshold value above zero (0). The testing results reveals that the (Q^2) value of all variables above zero (0) indicates predictive linkages as shown in Table 5.
- Testing relative impact (q^2), which carried out by blindfolding method. This measurement is done to measure the relative influence of a predictive link between a variable and other variables. The threshold used is equal to f^2 which is around 0.02 for a small effect, 0.15 for a middle effect, and 0.35 for a big effect as shown in Table 5.

Table 5. The structural model assessments hypothesis

Hip	Hypothesis		β	t -test	R^2	f^2	Q^2	q^2	Analysis			
	Path								β	t -test	R^2	f^2
H1	INC -> ITIR		-0.105	0.845	0.852	0.006	0.653	0.003	Insig	R	a	S
H2	INC -> PCS		0.801	10.087	0.724	1.396	0.550	0.684	Sig	A	a	L
H3	INC -> PPL		0.852	16.366	0.825	2.490	0.637	0.978	Sig	A	a	L
H4	INC -> SVQ		0.844	15.992	0.820	2.381	0.624	0.911	Sig	A	a	L
H5	INC -> TCH		0.806	15.133	0.800	1.956	0.626	0.857	Sig	A	a	L
H6	ITC -> ITIR		0.098	1.745	0.852	0.033	0.653	0.011	Insig	R	a	S
H7	ITC -> PCS		0.075	0.867	0.724	0.013	0.550	-0.003	Insig	R	a	S
H8	ITC -> PPL		0.084	1.593	0.825	0.022	0.637	0.007	Insig	R	a	S
H9	ITC -> SVQ		0.093	1.372	0.820	0.031	0.624	0.013	Insig	R	a	S
H10	ITC -> TCH		0.131	2.262	0.800	0.052	0.626	0.023	Sig	A	a	S
H11	PCS -> ITIR		0.225	1.708	0.852	0.060	0.653	0.017	Sig	R	a	S
H12	PPL -> ITIR		0.347	2.689	0.852	0.087	0.653	0.029	Sig	A	a	S
H13	SVQ -> ITIR		0.265	1.806	0.852	0.053	0.653	0.017	Sig	R	a	S
H14	TCH -> ITIR		0.155	1.280	0.852	0.020	0.653	0.005	Sig	R	a	S

Notes: sig: significant; insig: insignificant; R: rejected; A: accepted; a: accurate; S: small; L: large

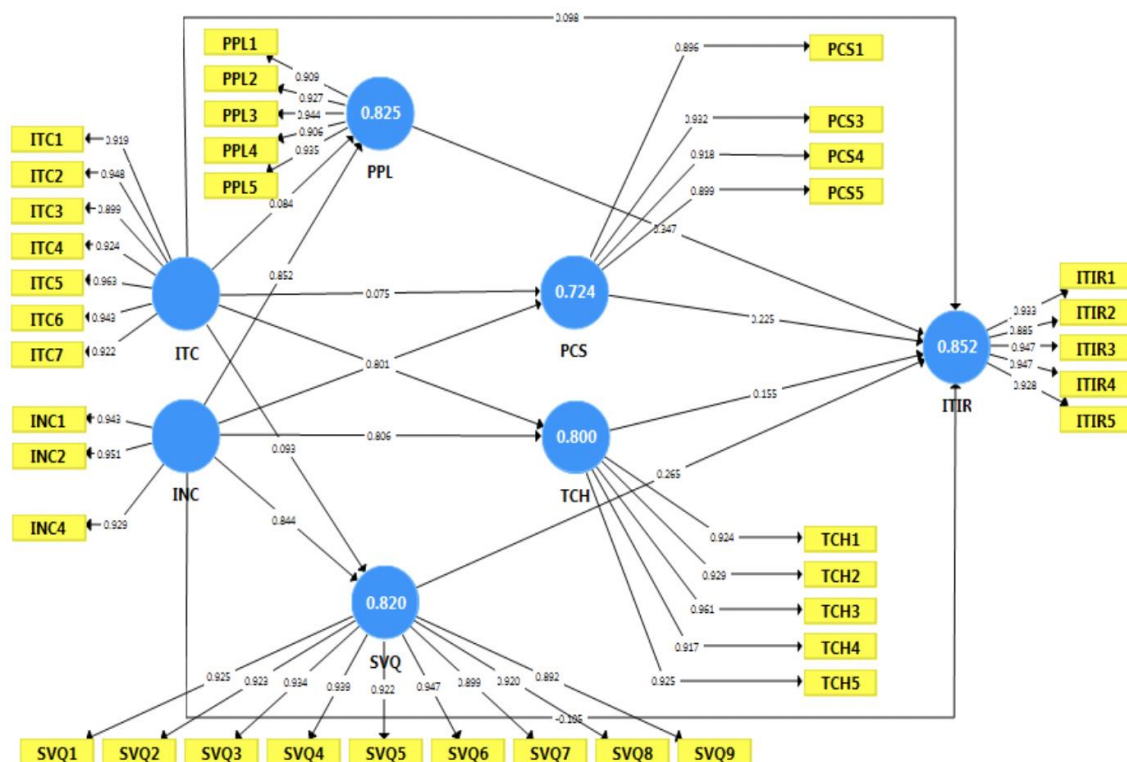

Figure 5. Results of the SmartPLS Analysis

4. DISCUSSION

First of all, the descriptive analysis reveals that IT need is operationally more than 60%, and even the majority of respondents already have IT development strategic plan (85%). As matter of fact, planning has come to the technical stage, in which IT implementation architecture reaches 59%, while the ownership of IT implementation roadmap reaches 52%. Strategically and operationally, These phenomenon is not surprise when referring to HEI's needs for IT. This is consistently in line with IT planning strategic theory which shows that the achievement of HEI's vision can be realized through IT implementation [35]–[37].

Second, in spite of the measurement model assessments represented statistically the good psychometric properties, with the indication that there are only two rejected indicators, namely INC3 and PCS2. It should be noted that the indicator rejection affects the created model. Therefore, it is necessary to develop instruments so that the data collected does not have biased information [38], in addition, it is necessary to consider the knowledge and environment of the respondents, because they can affect the results of the questionnaire too [39], [40]. So that, it is recommended to focus and minimize this problem in

subsequent research by increasing sample size and analyzing systematic errors by attention to research design, participants and data collection.

Third, the similar tendency was found across the results of the four structural model assessments ($\beta, t - tes, R^2, q^2$). The five of the 14 paths had statistically insignificant effects in β assessment and rejected in t-test examination, small predictive influences (f^2) and small relative impact of the predictive relevance (q^2), especially related to INC and PCS variables. In the case of INC and PCS, there are inconsistencies with the procession and causal concepts of the readiness and ZEN framework as the basis for model development. In addition, PCS cases are not consistent with e-readiness theory [41] so that it is not surprising to note that the majority of respondents (85%) stated that IT has been used operationally more than 61%. This inconsistency may be related to the development of a model or cultural problem that applies in the institution being sampled.

5. CONCLUSION

The research finding shows research sustainability from the previous studies until the pilot study. Readiness study is conducted to develop a framework and conceptual model, and to validate the model quantitatively. In particular, this pilot study elaborates the status of IT implementation readiness in HEI and the factors that influence it. In addition, the result of this pilot study can be used to complete the model; by paying attention to the research design, participant, data collection and data measurement, data analysis and publication of the analysis results.

Moreover, there are two limitations that researchers must keep in their minds. First, research finding cannot be generalized to other institutions because data is influenced by the condition of an institution being studied. Second, although the involvement of stakeholders in IT implementation is intended to obtain the completeness of the research results in connection with key information aspects, the stakeholder's involvement of each institution may also be somewhat different regarding certain issues presented in the survey instrument. Therefore, the subjective conditions of institution are out of control for possible analysis results in this study.

In addition, there are two main important points in this study. First, the status of IT implementation readiness in HEI can take to be one of the practical consideration points for sampled institutions policy makers regarding the availability of strategic planning and PCS issues to ensure that IT implementation can be carried out properly and correctly. Second, the use of INC can be rejected with respect to insignificant pathways, hypotheses rejection, and influences that have little impact and predictive relevance in future studies. Thus, further research can adopt this these findings, by reconsidering the limitations of this study.

ACKNOWLEDGEMENTS

Authors wishing to acknowledge Research and Publication Centre of UIN Sunan Gunung Djati Bandung that supports and funds this research publication.

REFERENCES

- [1] Mms. Fauziah, S.Kom, *Pengantar Teknologi Informasi*. Bandung: Muara Indah, 2010.
- [2] R. E. Indrajit, "PERANAN STRATEGIS TIK DALAM DUNIA PENDIDIKAN," 2011.
- [3] R. E. Indrajit, "Renstra tik," *Seri 999 E-Artikel Sist. dan Teknol. Inf.*, no. C, 2012.
- [4] M. Ali and F. Wahid, "Permasalahan Implementasi Sistem Informasi Di Perguruan Tinggi Swasta," *J. Ilm. Teknol. Sist. Inf.*, vol. 2, no. 1, pp. 17–21, 2016.
- [5] A. R. Aradea, Husni Mubarak, "Blueprint Teknologi Informasi Untuk Mengintegrasikan Sistem Informasi Perguruan Tinggi," no. APRIL 2013, pp. 1–6, 2010.
- [6] G.-G. Lee and B. Rong-Ji, "Organizational mechanisms for successful IS/IT strategic planning in the digital era," *Manag. Decis.*, vol. 41, no. 1/2, pp. 32–42, 2003.
- [7] H. Dwi Apriyanto, Rudi. and Prihantono Putro, "Tingkat kegagalan dan keberhasilan proyek sistem informasi di indonesia," *Semin. Nas. Teknol. Inf. dan Komun. 2018 (SENTIKA 2018)*, vol. 2018, no. Sentika, pp. 23–24, 2018.
- [8] A. Subiyakto, A. R. Ahlan, M. Kartiwi, and S. J. Putra, "Measurement of the information system project success of the higher education institutions in Indonesia: A pilot study," *Int. J. Bus. Inf. Syst.*, vol. 23, no. 2, 2016.
- [9] M. Irfan, S. J. Putra, and C. N. Alam, "E-Readiness for ICT Implementation of the Higher Education Institutions in the Indonesian," *6th Int. Conf. Cyber IT Serv. Manag. (CITSM 2018)*, no. CITSM, pp. 3–8, 2018.
- [10] A. Molla and P. S. Licker, "Perceived E-Readiness Factors in E-Commerce Adoption: An Empirical Investigation in a Developing Country," *Int. J. Electron. Commer.*, vol. 10, no. 1, pp. 83–110, 2005.
- [11] A. Tarvid, *Measuring the E-Readiness of Higher Education Institutions*, vol. 6, no. 102, 2008.
- [12] E. C. W. Lou and J. S. Goulding, "Organisational E-Readiness in the Built Environment : People , Process ," 2008.
- [13] M. Kashora and T. M. Waema, "ICT Indicators in Higher Education : Towards an E-readiness Assessment

- Model,” *Proc. reports 4th UbuntuNet Alliance Annu. Conf.*, pp. 57–76, 2011.
- [14] H. Alaaraj and F. W. Ibrahim, “An Overview and Classification of E-Readiness Assessment Models,” *Int. J. Sci. Res. Publ.*, vol. 4, no. 12, pp. 1–5, 2014.
- [15] Marcel, “A study of TESCA an Indonesia’ higher education e-readiness assessment model,” *2015 Int. Conf. Inf. Technol. Syst. Innov. ICITSI 2015 - Proc.*, 2016.
- [16] M. Kiula, E. Waiganjo, and J. Kihoro, “Novel E-Readiness Accession in Higher Education Institutions in Kenya,” *Int. J. Manag. Stud. Res.*, vol. 5, no. 6, pp. 101–111, 2017.
- [17] Sugiyono, “Metoder Penelitian Evaluasi,” *Alfabeta*, 2018.
- [18] J. W. Creswell, *Research Design: Qualitative, Quantitative, and Mixed Methods Approaches*. 2013.
- [19] M. P. J. D. Sinko, “Factors Influencing Implementation of ICT in Higher Education,” *Springer*, 2002.
- [20] C. Machado, “Developing an e-readiness model for higher education institutions: Results of a focus group study,” *Br. J. Educ. Technol.*, vol. 38, no. 1, pp. 72–82, 2007.
- [21] M. Irfan, S. J. Putra, C. N. Alam, A. Subiyakto, and A. Wahana, “Readiness factors for information system strategic planning among universities in developing countries: A systematic review,” in *Journal of Physics: Conference Series*, vol. 978, no. 1, 2018.
- [22] R. A. Dos Reis and M. Do Carmo Duarte Freitas, “Critical factors on information technology acceptance and use: An analysis on small and medium Brazilian clothing industries,” *Procedia Comput. Sci.*, vol. 31, no. Itqm, pp. 105–114, 2014.
- [23] A. Subiyakto, A. R. Ahlan, M. Kartiwi, S. J. Putra, and Y. Durachman, “The user satisfaction perspectives of the information system projects,” *Indones. J. Electr. Eng. Comput. Sci.*, vol. 4, no. 1, pp. 215–223, 2016.
- [24] A. Wahyudin and Z. A. Hasibuan, “Research Classification in Strategic Information System Planning Development: A Critical Review.”
- [25] F. Wabwoba, S. Omuterema, G. Wanyembi, and K. Omieno, “Green ICT Readiness Model for Developing Economies: Case of Kenya,” *Int. J. Adv. Comput. Sci. Appl.*, vol. 4, no. 1, pp. 51–65, 2013.
- [26] R. Kurdi, A. Taleb-Bendiab, M. Randles, and M. Taylor, “E-Government information systems and cloud computing (Readiness and analysis),” *Proc. - 4th Int. Conf. Dev. eSystems Eng. DeSE 2011*, pp. 404–409, 2011.
- [27] Marcel, “A conceptual green-ICT implementation model based-on ZEN and G-readiness framework,” *2016 Int. Conf. Informatics Comput. ICIC 2016*, no. Icic, pp. 99–104, 2017.
- [28] M. Irfan, J. P. Syopiansyah, and A. R. Muhammad, “The Readiness Model of Information Technology Implementation among Universities in Indonesia,” *IOP Conf. Ser. Mater. Sci. Eng.*, 2018.
- [29] N. A. Ismail, R. H. R. M. Ali, R. M. Saat, and H. M. Hsbollah, “Strategic information systems planning in Malaysian public universities,” *Campus-Wide Inf. Syst.*, vol. 24, no. 5, pp. 331–341, 2007.
- [30] V. Venkatesh and S. A. Brown, “Research Essay B Ridging The Q Ualitative –Q Uantitative D Ivide : Guidelines For C Onducting M Ixed M Ethods,” *MIS Q.*, vol. X, no. X, pp. 1–34, 2013.
- [31] A. Rind, “Some Whys and Hows of Experiments in Human–Computer Interaction,” *Found. Trends® Human–Computer Interact.*, vol. 5, no. 4, pp. 299–373, 2013.
- [32] H. S. H. Gombachika and G. Khangamwa, “ICT readiness and acceptance among TEVT students in University of Malawi,” *Campus-Wide Inf. Syst.*, vol. 30, no. 1, pp. 35–43, 2012.
- [33] C. M. R. and R. R. S. Jorg Henseler, “Advances in International Marketing,” *Adv. Int. Mark.*, vol. 20, no. 2009, pp. 361–388, 1999.
- [34] K. K.-K. Wong, “Partial Least Squares Structural Equation Modeling (PLS-SEM) Techniques Using SmartPLS,” *Mark. Bull.*, vol. 24, no. 1, pp. 1–32, 2013.
- [35] H. H. Md Hafiz Selamat, Mohd Adam Suhaimi, “Integrating Strategic Information Security with Strategic Information Systems Planning (SISP) Md Hafiz Selamat,” pp. 1–16, 2015.
- [36] S. Rogerson and C. Fidler, “Strategic Information Systems Planning : Its Adoption and Use,” 2006.
- [37] A. Amrollahi, A. H. Ghapanchi, and A. Talaei-Khoei, “Three decades of research on strategic information system plan development,” *Commun. Assoc. Inf. Syst.*, vol. 34, no. 1, pp. 1439–1467, 2014.
- [38] H. Malone, H. Nicholl, and C. Tracey, “Awareness and minimisation of systematic bias in research,” *Br. J. Nurs.*, vol. 23, no. 5, pp. 279–282, 2014.
- [39] J. Smith and H. Noble, “Bias in research,” *Evid. Based Nurs.*, vol. 17, no. 4, pp. 100–101, 2014.
- [40] D. Yuniarto, M. A. Helmiawan, and E. Firmansyah, “Technology Acceptance in Augmented Reality,” *J. Online Inform.*, vol. 3, no. 1, p. 10, 2018.
- [41] A. Wahyudin and Z. A. Hasibuan, “Research classification in strategic information system planning development: A critical review,” in *Proceedings - 2015 International Conference on Science in Information Technology: Big Data Spectrum for Future Information Economy, ICSITech 2015*, pp. 287–292, 2015.