

Analysis of LTE physical channels overhead

Haider Mohammed Turki Al-Hilfi

Directorate General of Vocational Education, Ministry of Education, Iraq

Article Info

Article history:

Received May 12, 2020

Revised May 29, 2020

Accepted Jun 11, 2020

Keywords:

LTE

MIMO

PBCH

PDCCH

PDSCH

PSS

SSS

ABSTRACT

LTE Network is the common mobile technology these days around the world and all service providers seek to how improve the network capacity and deliver the best performance in terms of delivered data rates and coverage area. LTE network consists of many protocols that work together to establish network connectivity, these protocols add variable headers that contains many control information that the network needs to operate. At the same time these headers decrease the effective capacity of the network, so there is a need to optimize the overhead size that used in various channels. The study will illustrate the different overheads that effect on the network capacity and investigate the effect of different values on achieving the best network capacity.

This is an open access article under the [CC BY-SA](#) license.

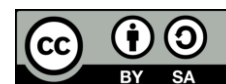

Corresponding Author:

Haider Mohammed Turki Al-Hilfi,
Directorate General of Vocational Education,
Ministry of Education,
AL Najaf, Iraq.
Email: hi.1977@yahoo.com

1. INTRODUCTION

The One of the main advantages of 4G-LTE is the high throughput comparing to 3G and 2G mobile networks. 4G LTE can delivers high mobile maximum data rate that reach more than 300 Mbps in downlink direction. This throughput can be achieved if the network has 20 MHz and deploy MIMO. Actually, this data rate is raw data rate that include the control information data rate and it assume excellent radio condition and error free transmission. The number of LTE subscribers were 1.2 billion in 2016 and estimated to be 4.3 billion by 2021 [1-3].

LTE network consists of two parts as shown in Figure 1, namely the radio access and network core parts. The core side is called evolved-packet core (EPC) and the radio part is named evolved universal terrestrial access network (EUTRAN). The main function of EPC is to provide access to other networks based on internet protocol (IP). The functions of EPC are performed using the following nodes, packet-gateway (PGW), mobility management entity (MME) and, serving gateway (SGW) [4, 5]. LTE utilize OFDMA in downlink and SCFDMA in uplink plus MIMO support. Orthogonal frequency-division multiple-access (OFDMA) delivers good spectrum efficiency, small packet delay, and high transfer rates [6-10].

eNB is the only element in the access network compared with 2G and 3G networks, it executes many functions like dynamic network resource allocation (scheduling), IP header compression/de-compression, handover, and many others. Network planning is the most vital step in establishment of 4G-LTE mobile network and maintaining its high performance. Dimensioning stage in the planning process involves a sequential step of calculations which have different needs like antenna radiation pattern, simulation capacity requirements, coverage requirements [11-13]. There are many categories in LTE planning and optimization

processes, one of them is parameters' planning which is determining the best parameters for the different protocols that results in optimum network performance. The determination of the size of the channel headers is considered main part of configuration planning. For example, PRACH, PUCCH, and PDCCH planning. The remaining parts of the study is presented as follows: a brief technical overview regarding LTE layers and protocols presented in part two. Section three presents the different function and parameters of physical channels. Numerical results will be listed in part four and conclusion will be illustrated in section five.

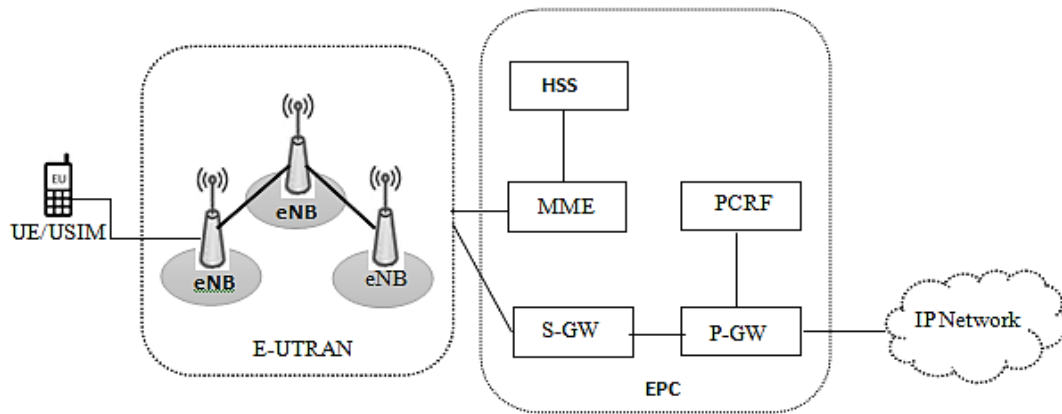

Figure 1. LTE network components

2. EXPLAINING LTE LAYERS AND PROTOCOLS

In 2008 release 8 of LTE specifications was ready. Release 9 was introduced by ending of 2009 with many new features. Release 10-LTE-Advanced (LTE-A) released at 2010 and it is considered a huge improvement in LTE evolutions due to many new features like Multi-Input Multi-Output, heterogeneous networks (HetNets), carrier aggregation (CA), and coordinated multi-point transmission/reception (CoMP). The current work is now ongoing for Release 16 which is called 5G phase 2 [4, 14]. LTE in high giga range (5GHz) unlicensed band, called license assisted access (LAA) and LTE-U technologies, will be grow in the near future like licensed bands due to increasingly loading [5].

In OFDMA, the band are divided into sub-carriers spaced by 15 kHz and 12 adjacent sub-carriers, that together occupy 180 kHz named resource block (RB) which is the minimum bandwidth allocation possible. From time view these 12 subcarriers has 0.5 ms which called slot. The maximum RBs' number based on the network bandwidth as listed in Table 1 [6, 15, 16].

Table 1. Resource Blocks vs. BW

| System Name | Value | | | | | |
|-----------------|-------|----|----|----|----|-----|
| Bandwidth - MHz | 1.4 | 3 | 5 | 10 | 15 | 20 |
| RB | 6 | 15 | 25 | 50 | 75 | 100 |

From time perspective LTE frame has 10 ms length that divided to 10 subframes. Every subframe has two equal slots which consist of 7 or 6 OFDMA symbols (cyclic prefix dependent normal or extended) in case of FDD. MAC layer used to map the transport channels to physical channels and it performs scheduling functions in eNB every TTI by assigning RBs to mobile subscribers. The scheduler also determines different transmission parameters like transmitted power and modulation/coding scheme (MCS) which pointed to as radio link adaptation [7, 17-20]. LTE supports various MCS which can be changed per 1 ms subframe based on wireless channel conditions and interference. The different types of supported modulation include 64QAM, 16QAM, and QPSK [8, 21, 22]. All user traffic and signaling traffic are organized in channels. Figure 2 and Figure 3 display the different layers and channels of LTE DL and UL protocols that consists of three different layers, logical, transport, and physical layers. Their target is to delivers different ways for different types of data on the logical layer and to separate the characteristics of the physical channel below from the logical data flows.

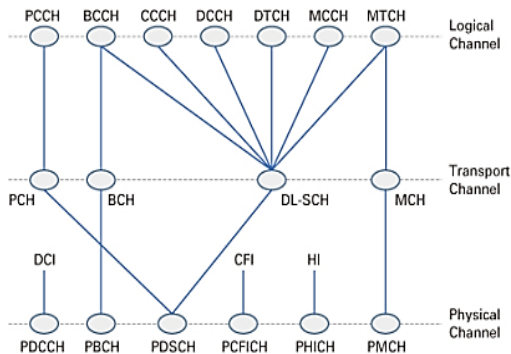

Figure 2. LTE network layers-DL

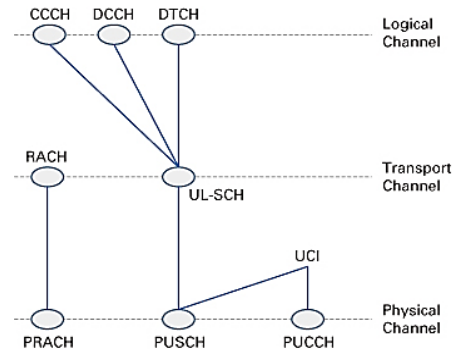

Figure 3. LTE network layers-UL

3. PHYSICAL SIGNALS AND CHANNELS

The network determines a number of RBs to a UE for each new TTI (i.e 1 ms subframe). Depending on the location of RBs, it carry different types of traffic in the frequency time matrix. Cell reference signals (CRS) is transmitted in a predetermined RBs and used in DL channel estimation by different US's [14, 23, 24]. CRSs are included for each antenna. Resource elements (REs) allocated to CRS on one antenna are not used on the other antennas (called discontinuous transmission RTX). CRSs are inserted in every sixth frequency subcarrier and in seventh time symbol on the resource grid. The network has 504 different reference sequence signal sequences.

Synchronization signals (PSSs/SSSs) are sent twice in every TTI (i.e. transmitted every 5 ms in first and sixth TTI) on the middle 62 subcarriers and it used for initial synchronization [9]. It is assumed that these signals are transmitted from the first antenna while the other antenna apply DTX to the corresponding resource elements [10]. Physical Broadcast Channel (PBCH) uses three OFDMA symbols on 72 subcarriers in the middle of a channel every fourth LTE frame. PBCH is broadcasted every 40 ms and follows the synchronization signals [9, 25, 26]. PBCH carries system information for all UEs that contains the bandwidth, system frame number (SFN), and hybrid ARQ indication channel (PHICH) length [27, 28]. It is QPSK modulated and is transmitted on all antennas [11].

PCFICH information determines the PDCCH size and is sent at each of subframe beginning [29]. This channel contains a value of 2-bit length called control format indicator (CFI), and encoded using 1/16 code rate during the first symbol within each TTI [11]. Physical downlink control channel (PDCCH) data indicates where, when, and what type of information is assigned for each UE on the data channel and which resources can be used in the uplink direction. This information occupies the first symbols (from one to four OFDMA symbols) over the total bandwidth in each TTI.

PDCCH delivers resource scheduling data like downlink RBs, and power control commands. This information called DCI (downlink control information) that is sent as a set of control channel elements (CCEs). One element of CCE consists of 9 resource element groups (REGs). Each REG is made up of 4 REs that carries 2 bits. 1, 2, 4 or 8 CCEs can be transmitted in PDCCH channel. QPSK is the only method used in this channel [12].

To acknowledge the reception of data blocks in uplink direction, there is some symbols that is reserved for this purpose. This is executed by HARQ protocol and PHICH channel [9]. Each group of PHICH uses 12 resource elements. PHICH groups $N_{g, PHICH}$ is calculated from the number of resource blocks $N_{RB, DL}$ and the PHICH group scaling factor N_g . the scaling factor take on of the following values the scaling factor 2, 1, 1/2, or 1/6.

$$N_{g, PHICH} = \{N_g * N_{RB, DL} / 8; \text{ for normal Prefix}, 2 * N_g * N_{RB, DL} / 8; \text{ for extended Prefix}\} \quad (1)$$

The downlink shared channel (PDSCH) is allocated the REs which have not been used by the signals nor the other physical channels and is used to user traffic. The PDSCH is not able to use resource elements which belong to the same symbol as the PHICH, PCFICH or PDCCH. The PDCCH data is padded with DUMMY data prior to an interleaving function. The DUMMY data is used to ensure that the combined PDCCH plus DUMMY data occupies an integer number of symbols. The subcarriers occupied by the PDCCH depend upon the cell identity.

In uplink direction, there are three channels in LTE physical layer. Physical uplink shared channel (PUSCH) that uses QPSK and 16QAM, and optionally 64QAM modulation. This channel used to carry user data. PUSCH carries control messages that used to decode the user traffic and MIMO parameters, in addition to user traffic. Physical control channel (PUCCH) carries control information in uplink and its size is

configurable. Random-access channel (PRACH) is used to let UEs get access to LTE network and it is the only non-synchronized channel in the uplink [13].

4. RESULTS

This study declares the effects of different values of physical channels' parameters on the remaining resources for data traffic. The study will find the maximum cell capacity through simple calculations. Table 2 lists the percentages of overheads for different signals and channels. The calculations are done for 2*2 and 4*4 MIMO using 3MHz BW. From the table it is clear that the largest percentage belongs PDCCH channel. The value of DTX RE changes with the amount of REG that is selected for PDCCH channel. The amount of channel overhead percentage for 4*4 MIMO is fixed compared with 2*2 MIMO scenario in PBCH, PCFICH, and PHICH, this is due to sending the same messages on all antennas. RS and PSS/SSS overheads decreased because of decreasing the REs that used for RSs in 4*4 MIMO, and using DTX instead of PSS/SSS in other antennas, respectively.

Table 2. Percentage of physical channels overhead for 3 MHz BW

| Percentage of Physical channels | Value | |
|---------------------------------|-------|------|
| | 2*2 | 4*4 |
| MIMO | 2*2 | 4*4 |
| RS % | 4.7 | 3.6 |
| PSS/SSS % | 0.25 | 0.12 |
| PBCH % | 0.95 | 0.95 |
| PCFICH % | 0.63 | 0.63 |
| PHICH % | 0.95 | 0.95 |
| DTX % | 5.5 | 11.6 |
| PDCCH % | 9.5 | 7.3 |
| PDSCH % | 76.3 | 74.1 |

Figure 4 declares the effect of increasing the RBs for PDCCH channel on the remaining RBs for PDSCH. The PDSCH increasing in a step format because LTE cannot use part of the REs along the same symbol used for PDCCH, so the remaining REs from PDCCH REG is filled by dummy symbol that cannot be used by PDSCH channel. Figure 5 describes the relation between using different modulation and coding techniques and maximum cell capacity. The capacity here is the raw throughput that suppose 100 % load on the cells. The calculations suppose 3 MHz and 2*2 MIMO technique. The figure shows that the maximum spectral efficiency is 6.6 using 64QAM and without adding redundancy data. Although this is not practical in many environments but it shows the difference between the different MCS.

Figure 6 declare the maximum cell capacity using different MIMO schemes. Using 4*4 MIMO duplicate the cell capacity due to using more REs in PDSCH channel. Note that using 4*4 MIMO decrease the total overhead of RS and PDCCH channel as showed in following figure. The relation between increasing PDCCH REG number on the maximum cell capacity is shown in Figure 7. The figure shows that the maximum cell capacity decreased by amount of 5 Mbps as a result of increasing the PDCCH symbols from 1 to 3. The figure also displays the great difference between using 0.25 coding rate and 1 coding rate, this difference reaches 20 Mb/s in small number of PDCCH REG. This explain the difference between cell edge throughput which use low coding rate and throughput close to eNB site. Actually, in LTE no coding rate equal to 1 is used but the graph shows the concept of using different coding rate.

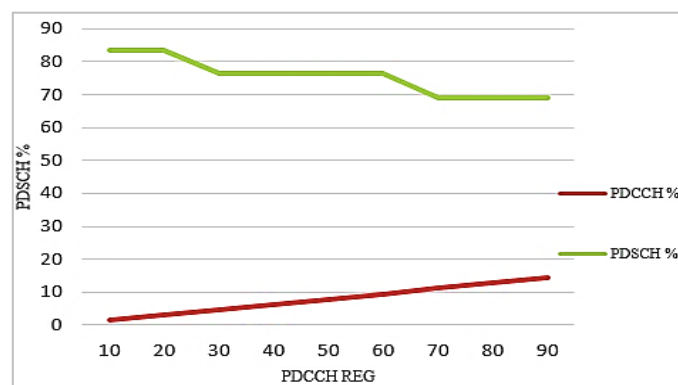

Figure 4. PDCCH REG vs. PDSCH % for 3 MHz BW

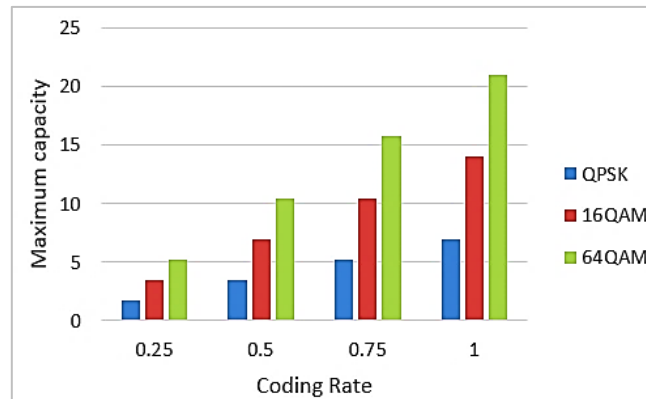

Figure 5. Maximum capacity vs. MCS using 3 MHz

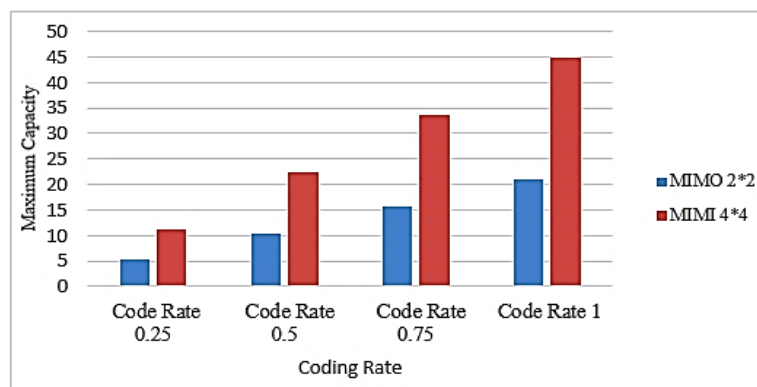

Figure 6. MIMO vs. Maximum capacity

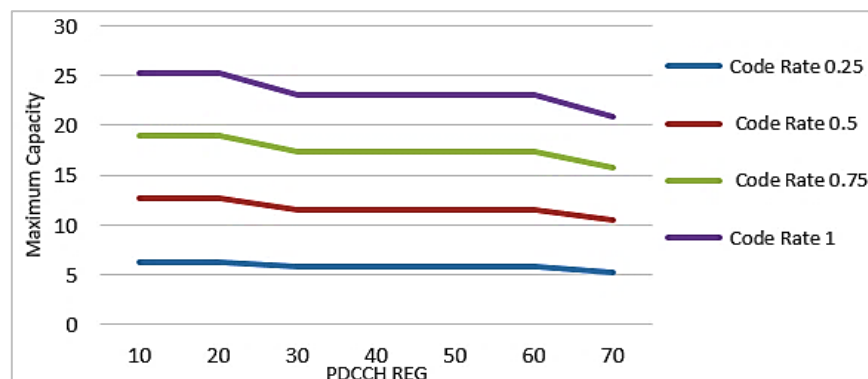

Figure 7. Maximum cell capacity vs. PDCCH REG using 3 MHz

Most of service providers use high BW for their LTE networks, so the relation between the amount of REG in PDCCH and PDSCH need to investigated using different BW which is shown in Figure 8. The figure displays the effect of PDCCH overhead is very small using 20 MHz this is due to the large number of RBs in high BW values. Figure 9 declares the effect of using different BW on the maximum cell capacity using 2*2 and 4*4 MIMO. The figure shows that it is better to use high BW with 4*4 MIMO because the difference between the capacity becomes greater using high BW, this is due to increasing the PDSCH REs percentage compared with PDCCH REG percentage as shown in Figure 8. UL channels also follow the same route but with a smaller number of control channels. The main control channel in UL direction is PUCCH. Table 3 declare the relation between the number of RBs for PUCCH and the total system overhead.

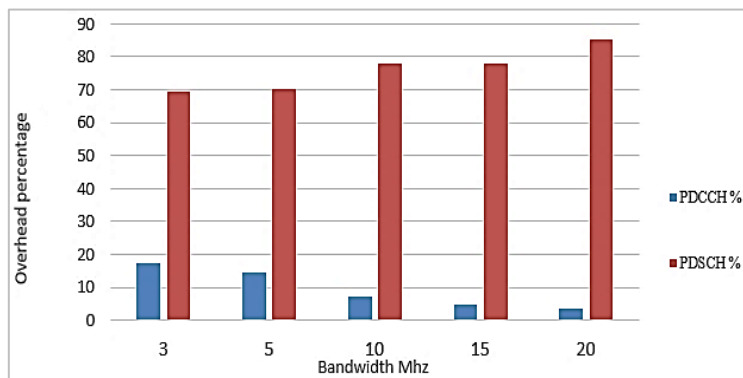

Figure 8. PDSCH % vs. PDSCH% in different BW

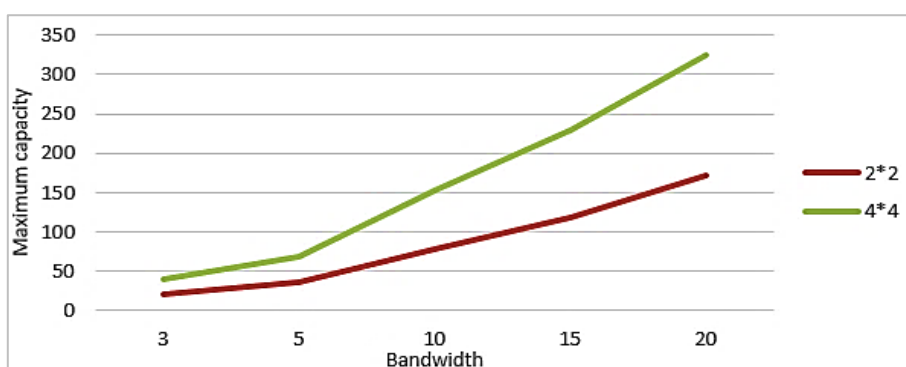

Figure 9. Maximum cell capacity vs. BW using 2*2/4*4 MIMO

Table 3. Total system overhead vs. PUCCH RBs

| System Name | Value | | | | |
|-------------------------|-------|----|----|----|----|
| Number of RBs for PUCCH | 1 | 2 | 3 | 4 | 5 |
| Total System Overhead % | 19 | 20 | 22 | 24 | 26 |

5. CONCLUSION

The choice of the planning parameters in LTE network planning processes has great effect on the network performance from coverage, and capacity perspectives. The paper presents numerical analysis of physical channels overhead in downlink and uplink directions. Channel overheads have great effects on the remaining resources for data traffic and final cell capacity. From analysis it is shows that PDCCH has a great effect on PDSCH resources, up to 17 % of LTE network resources can be used in PDCCH. The study also shows the effect of increasing the numbers of antennas that used in MIMO. The results declare that using 4*4 MIMO the maximum capacity reaches 325 Mbps using 20 MHz bandwidth compared with 170 Mbps using 2*2 MIMO. It is shown that changing coding rate in downlink direction increase the maximum rate due to reducing the redundancy bits, for example the capacity increase from 5 to 20 Mbps by increasing coding rate from 0.25 to 1.

REFERENCES

[1] E. T. Tchao, J. D. Gadze, J. O. Agyapong, "Performance Evaluation of a Deployed 4G LTE Network," *International Journal of Advanced Computer Science and Applications*, vol. 9, no. 3, pp. 165-178, 2018.

[2] A. Jemmali, "Performance evaluation and analysis of mimo schemes in lte networks environment," Thesees Doctor, Universit'e De Montr' Eal, 2013.

[3] Ghassan A. Abed, M. Ismail, K. Jumari, "Modeling and Performance Evaluation of LTE Networks with Different TCP Variants," *Engineering and Technology International Journal of Electronics and Communication Engineering*, vol. 5, no. 3, pp. 443-448, 2011.

[4] E. T. Tchao, J. D. Gadze, J. O. Agyapong, "Performance Evaluation of a Deployed 4G LTE Network," *International Journal of Advanced Computer Science and Applications*, vol. 9, no. 3, pp.165-178, 2018.

- [5] S. K. Saha, C. Vlachou, D. K., K. H. Kim, "DeMiLTE: Detecting and Mitigating LTE Interference for Enterprise Wi-Fi in 5 GHz," *Conference: The Twentieth ACM International Symposium*, pp.31-40, 2019.
- [6] Rui André de Almeida Pires, "Coverage and Efficiency Performance Evaluation of LTE in Urban Scenarios," Dissertation submitted for obtaining the degree of Master in Electrical and Computer Engineering, Universidade de Lisboa, October 2012.
- [7] O. Iosif, I. Bănică "LTE Performance Evaluation Based on two Scheduling Models," *International Journal on Advances in Networks and Services*, vol. 5, no. 1 & 2, pp. 58-68, 2012.
- [8] M. A. Mohamed, et al., "Performance Analysis of LTE-Advanced Physical Layer," *International Journal of Computer Science Issues*, vol. 11, no 1, pp. 80-87, 2014.
- [9] M. Sauter, "From GSM to LTE-Advanced Pro and 5G," Third Edition, *John Wiley & Sons Ltd*, 2017.
- [10] LTE in Bullets Books. [Online]. Available: www.lte-bullets.com, 2020.
- [11] R. M. Rao, S. Ha, V. Marojevic, J. H. Reed, "LTE PHY Layer Vulnerability Analysis and Testing Using Open-Source SDR Tools," *Conference: MILCOM 2017 - 2017 IEEE Military Communications Conference (MILCOM)*, 2017.
- [12] S. Syed Ameer Abbas, et al., "Implementation of pipelined architecture for physical downlink channels of 3gpplte," *International Journal of Next-Generation Networks*, vol. 5, no. 1, pp. 1-20, 2013.
- [13] A. Z. Yonis, M. F. L. Abdullah, "Downlink and Uplink Physical Channels in Long Term Evolution," *I. J. Information Technology and Computer Science*, vol. 11, pp. 1-10, 2012.
- [14] M. Meidlinger, Qi Wang "Performance Evaluation of LTE Advanced Downlink Channel Estimators," *2012 19th International Conference on Systems, Signals and Image Processing (IWSSIP)*, 2012.
- [15] M. A. Ahmed, R. A. Hasan, A. H. Ali, M. A. Mohammed, "The classification of the modern arabic poetry using machine learning," *TELKOMNIKA Telecommunication, Computing, Electronics and Control*, vol. 17, no. 5, pp. 2667-2674, 2019.
- [16] A. H. Ali, "Fuzzy generalized Hebbian algorithm for large-scale intrusion detection system," *International Journal of Integrated Engineering*, vol. 12, no. 1, pp. 81-90, 2020.
- [17] A. H. Ali, M. Z. Abdullah, "A novel approach for big data classification based on hybrid parallel dimensionality reduction using spark cluster," *Computer Science*, vol. 20, no. 4, pp. 413-31, 2019.
- [18] O. A. Hammood, et al., "An effective transmit packet coding with trust-based relay nodes in VANETs," *Bulletin of Electrical Engineering and Informatics*, vol. 9, no. 2, pp. 685-697, 2020.
- [19] O. A. Hammood, et al., "The VANET-Solution Approach for Data Packet Forwarding Improvement," *Advanced Science Letters*, vol. 24, no. 10, pp. 7423-7427, 2018.
- [20] O. A. Hammood, et al., "RESP: Relay Suitability-based Routing Protocol for Video Streaming in Vehicular Ad Hoc Networks," *International Journal of Computers, Communications & Control*, vol. 14, no. 1, pp. 21-38, 2019.
- [21] Z. H. Salih, et al., "Study the Effect of Integrating the Solar Energy Source on Stability of Electrical Distribution System," *2019 22nd International Conference on Control Systems and Computer Science (CSCS)*, pp. 443-447, 2019.
- [22] R. A. Hasan, M. A. Mohammed, N. Țăpuș, and O. A. Hammood, "A comprehensive study: Ant Colony Optimization (ACO) for facility layout problem," *2017 16th RoEduNet Conference: Networking in Education and Research (RoEduNet)*, pp. 1-8, 2017.
- [23] R. A. Hasan and M. N. Mohammed, "A krill herd behaviour inspired load balancing of tasks in cloud computing," *Studies in Informatics and Control*, vol. 26, no. 4, pp. 413-424, 2017.
- [24] M. A. Mohammed, R. A. Hasan, "Particle swarm optimization for facility layout problems FLP—A comprehensive study," *2017 13th IEEE International Conference on Intelligent Computer Communication and Processing (ICCP)*, pp. 93-99, 2017.
- [25] M. A. Mohammed, et al., "A Focal load balancer-based algorithm for task assignment in cloud environment," *10th International Conference on Electronics, Computers and Artificial Intelligence (ECAI)*, pp. 1-4, 2018.
- [26] M. A. Mohammed, A. A. Kamil, R. A. Hasan, and N. Tapus, "An Effective Context Sensitive Offloading System for Mobile Cloud Environments using Support Value-based Classification," *Scalable Computing*, vol. 20, no. 4, pp. 687-698, 2019.
- [27] M. A. Mohammed, I. A. Mohammed, R. A. Hasan, N. Țăpuș, A. H. Ali, and O. A. Hammood, "Green Energy Sources: Issues and Challenges," *2019 18th RoEduNet Conference: Networking in Education and Research (RoEduNet)*, pp. 1-8, 2019.
- [28] M. A. Mohammed and N. ȚĂPUȘ, "A Novel Approach of Reducing Energy Consumption by Utilizing Enthalpy in Mobile Cloud Computing," *Studies in Informatics and Control*, vol. 26, no. 4, pp. 425-434, 2017.
- [29] N. Q. Mohammed, et al., "Comparative Analysis between Solar and Wind Turbine Energy Sources in IoT Based on Economical and Efficiency Considerations," *2019 22nd International Conference on Control Systems and Computer Science (CSCS)*, 2019.