

MPPT for PV System Based on Variable Step Size P&O Algorithm

Awang Jusoh*¹, Rozana Alik², Tan Kar Guan³, Tole Sutikno⁴

^{1,2,3}Department of Power Electronics, Universiti Teknologi Malaysia, Johor, Malaysia

⁴Department of Electrical Engineering, Universitas Ahmad Dahlan, Yogyakarta, Indonesia

*Corresponding author, e-mail: awang@fke.utm.my

Abstract

This paper presents some improvements on the Perturb and Observe (P&O) method to overcome the common drawbacks of conventional P&O method. The main advantage of this modified algorithm is its simplicity with higher accuracy results, compared to the conventional methods. The operation of the entire solar Maximum Power Point Tracking (MPPT) system was observed through two different approaches, which are through MATLAB/Simulink simulation and hardware implementation. A small scale of hardware design, which consists of solar PV cell, boost converter and Arduino Mega2560 microcontroller, had been utilized for further verification on the simulation results. The simulation results that was carried out by this modified P&O algorithm showed improvement and a promising performance: faster convergence speed of 0.67s, small oscillation at steady state region and promising efficiency of 95.23%. Besides, from the hardware results, the convergence time of the power curve was able to maintain at 0.2s and give almost zero oscillation during steady state. It is envisaged that the method is useful in future research of Photovoltaic (PV) system.

Keywords: *perturb and observe, MPPT, variable step size, photovoltaic system*

Copyright © 2017 Universitas Ahmad Dahlan. All rights reserved.

1. Introduction

Today's scientists and engineers have introduced numerous researches and development with regard to renewable energy, in order to overcome the increasing negative impacts caused by the conventional energy sources. There is a major demand in solar energy as usable alternative energy source, due to its sustainability, cleanness, easy maintenance and noise-free characteristics. Moreover, there are many tropical countries in this world which receive direct solar irradiation around 1000 W/m² [1-4].

Despite the fact that solar energy is a promising energy, it still has some disadvantages in term of its performance. Reference [5] states that, the efficiency of the solar PV to transfer sunlight into electrical energy is quite low, approximately 12% until 20%. The solar PV operates according to the sunlight intensity, cell temperature and array configuration [6]. Numbers of methods have been introduced by researchers, and one of the most popular approach is the maximum power point tracking (MPPT). A conventional MPPT system consists of a switch-mode power converter, placed in between of the solar PV and the load. The duty cycle of the converter is measured by a control algorithm, to allow tracking of the maximum power point [7]. There are more than 19 distinct MPPT techniques available and being researched in the past few years [8].

The easiest way to apply the MPPT circuit and obtain the maximum power point (MPP) is Fractional Open Circuit Voltage (FOCV) method [9]. It is also known as a constant voltage technique which employs the linear relationship between voltage at MPP (V_{MPP}) and open circuit voltage (V_{OC}) as $V_{MPP} = K1 \times V_{OC}$. Likewise, Fractional Short Circuit Current (FSCC) technique utilizes the same concept as FOCV method. The equation used for FSCC is $V_{MPP} = K2 \times V_{OC}$ where a linear relationship between the PV short circuit current (I_{SC}) and current at MPP (I_{MPP}) is shown in this method. The value of proportionality constants ($K1$ and $K2$) are affected by the types of solar PV, surrounding temperature and irradiance [10]. According to reference [11], the range value for $K1$ is between 0.71 until 0.78 while $K2$ is ranging between 0.78 and 0.92. However, these techniques unable to track the accurate MPP because estimation is used to identify the linear relationship as described by reference [12].

It is widely known that Perturb and Observe (P&O) as well as Hill Climbing (HC) MPPT are the most favorable methods to be used in finding the real maximum power point (MPP) on the PV curve [13]. The main advantage of these techniques is relatively straightforward compared to the other artificial techniques [14]. Besides, these techniques are also easy to be implemented in practical application without prior knowledge on PV cell's characteristics and it can be used in any microcontroller or Digital Signal Processing (DSP) system [15]. Nonetheless, P&O algorithm is also referred as Hill Climbing (HC) MPPT by some researchers since it uses the same concept in perturbing the MPP [16]. The only difference is the output control variable; P&O MPPT provides reference voltage to the power converter while HC MPPT yields the change from the duty cycle. In fact, reference [17] stated that the transient response of P&O is better than HC. Yet, these methods have two major drawbacks: oscillation problem around the MPP and unable to track the real MPP during fast changing of weather condition which has been explained in detail in Section 4.

Incremental Conductance (INC) method is another version of Hill Climbing (HC). It uses the basic concept of HC which the slope of P-V curve will be zero at the MPP, positive at the left side and negative at the right side of the curve. The characteristic of INC compensates the weaknesses of P&O method as it is capable to track the MPP during rapid variation of sun irradiance [9, 12]. Nevertheless, it is difficult to obtain a constant MPP in practical, plus, this method requires additional sensors such as current and voltage sensor which increases the cost and complexity of the system.

Fuzzy Logic Control (FLC) is the most popular artificial control method due to the invention of microcontroller, whereby any complicated coding or algorithm can be easily programmed and implemented. The main advantage of FLC is able to handle non-linearity and imprecise input. Moreover, fast convergence speed and robust performance of fuzzy logic have been demonstrated during sudden change of surrounding condition as stated in reference [18]. Besides, Artificial Neural Network (ANN) is another technique that fits the operation of microcontroller and digital signal processor. Reference [19] proposed a solar system with multi-level neuro-fuzzy model for MPPT. The system has been proven capable in producing better efficiency and representing nonlinear characteristic of PV array under wide range of operation circumstance compared to conventional neural network algorithm. However, it is undeniable that the system with ANN needs to be periodically trained to guarantee the highest accuracy.

Basically, the conventional algorithms are rather simple methods. Yet, they usually cause poor efficiency. On the other hand, soft computing algorithms are more complex, but deliver higher efficiency [20]. In relation to the assumption, this paper is focusing on modifying and improving the P&O MPPT to overcome the drawbacks especially the steady state oscillation problem. The conventional P&O algorithm is modified to have variable step size with some combination of HC method will be described in detail in Section 4 as well as verification through simulation MATLAB/Simulink and hardware implementation in Section 5.

2. Photovoltaic (PV) Modelling

A single diode model (Figure 1(a)) is the most suitable model for MPPT research, regardless of all well-established PV cell modelling circuits from other references [21, 22]. Furthermore, some researchers have come out with several PV modelling circuits such as two diode model (Figure 1(b)) and simplified model (Figure 1(c)).

It is noticeable that two-diode configuration of PV provides high accuracy of output response because it involves the variance in low level current flow in the semiconductor's depletion region [23]. Yet, it is difficult to implement the equation in real life situation. Likewise, the simplified model of PV is able to neglect the presence of shunt resistance, hence the mathematical equation is more feasible [24]. Nevertheless, the single diode model still offers a better balance between simplicity and accuracy.

A detailed analysis and equations are provided by reference [21] to identify the value of each component of the single diode PV model. The characteristic equations of single diode model displayed in the equations below are divided into four types; the output current of solar PV (I_{PV}), current generated by light photon (I_{PH}), cell reverse saturation current (I_s) and cell saturation current at reference temperature (I_{RS}).

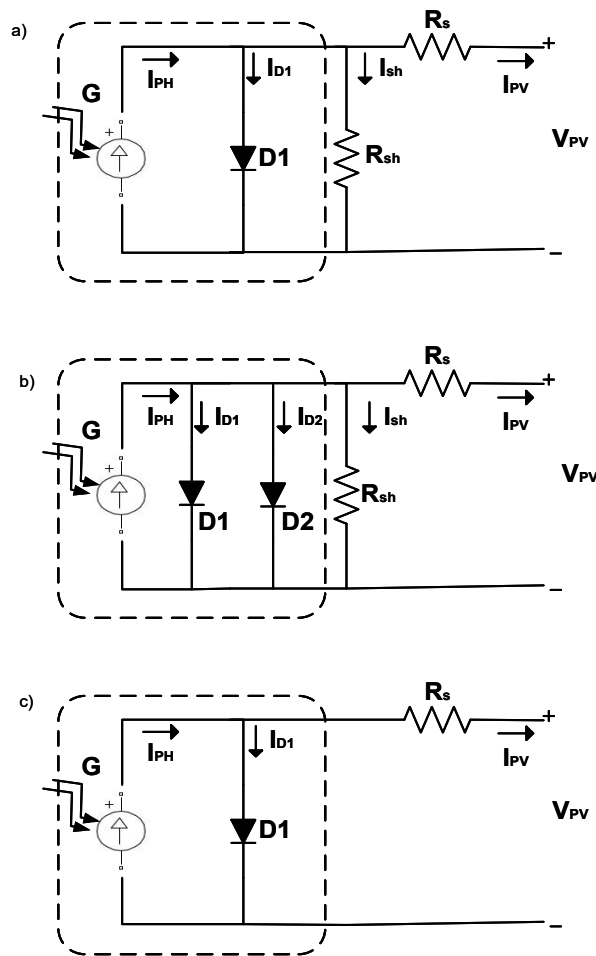

Figure 1. Solar PV modelling: (a) Single diode model (b) Two diode model (c) Simplified model

Output current of solar PV (I_{PV}):

$$I_{PV} = I_P - I_S \left[e^{q(V_{PV} + I \times R_S)/kT_C} - 1 \right] - [q(V_{PV} + I \times R_S)/R_{SH}] \quad (1)$$

I_{PV} can also be represented as in Equation (2):

$$I_{PV} = I - (A1/A2) \quad (2)$$

$$A1 = I_{PH} - I - I_S \left[e^{q(V_{PV} + I \times R_S)/kT_C} - 1 \right] \quad (3)$$

$$A2 = -I - I_S \left[e^{q(V_{PV} + I \times R_S)/kT_C} - 1 \right] [q(R_S)/kT_C A] \quad (4)$$

Current generated by light photon (I_{PH}):

$$I_{PH} = [I_{SC} + K_i(T_C - T_{ref})] G \quad (5)$$

Cell reverse saturation current (I_S):

$$I_S = I_{RS} (T_C/T_{ref})^{3/A} \left[e^{qE_G(1/T_{ref} - 1/T_C)/kA} \right] \quad (6)$$

Cell saturation current at reference temperature (I_{RS}):

$$I_{RS} = I_{SC} / [e^{qV_{OC}/kA N_s T_C} - 1] \quad (7)$$

where,

I_{SC}	: Short circuit current of solar cell
V_{OC}	: Open circuit voltage of solar cell
R_S	: Equivalent series
R_{SH}	: Shunt resistance
G	: Sun irradiation
A	: Ideality factor
N_S	: Number of cells in series
q	: Electron Charge, 1.6×10^{-19} C
k	: Boltzmann's constant, 1.38×10^{-23} J/K
T_C	: Cell Temperature
T_{ref}	: Reference Temperature
K_i	: Temperature Coefficient's Current

Regularly, some of the PV parameters such as open circuit voltage, short circuit current and temperature coefficient have been provided in the data sheet of solar PV based on the Standard Test Condition (STD): 1000W/m² of solar irradiation and 25°C of temperature. All the equations mentioned above were used in the MATLAB/Simulink simulation later in Section 5.

3. Switched Mode DC-DC Boost Converter

DC-DC converter is located between the referred photovoltaic module and load in MPPT system that alters a DC voltage to another level of DC voltage. It is important to design the DC-DC converter correctly in order to ensure the PV system is operating at the best efficiency as required. There are three main types that frequently used according to the system application: step up the input voltage (boost converter), step down the input voltage (buck converter) or combination of both operations (buck-boost converter) [25].

Buck converter and Boost converter are the most popular circuit and commonly used in the solar MPPT system due to the simplicity and low cost implementation [16]. Nonetheless, boost converter is more preferable compare to the buck converter since the output PV voltage are usually lower than the desired voltage at the external load. Additionally, the configuration of buck converter (switching component is place at input side and series with input voltage) had caused discontinuous current flow inside the system and result in energy losses during power generation process. Consequently, boost converter presents a great advantages in terms of cost saving and high efficiency [26].

Therefore, in this paper, boost converter is chosen to level up the input voltage and control the level of output power to the load. Fundamentally, the boost converter is consists of an inductor, a diode, a high frequency power MOSFET switch and capacitor. The input voltage of boost converter is controlled by the PV modelling circuit and the duty cycle for the converter is varied according to the output of MPPT. Figure 2 illustrates the basic circuit of boost converter used for this paper.

The operation of a boost converter is mainly rely on the opening and closing of the switch. The charging state is occurred when the switch is closed and second mode of operation (discharging state) will be initiated by opening the switch. The equation used to obtain the duty cycle for this converter is shown in the Equation (8).

In order to ensure the boost converter operates at continuous current mode (CCM), the size of inductor used plays an important role. Hence, the value of the inductor must be calculated precisely. Besides, the capacitor is necessary to diminish the ripple and noise at the output side of the boost converter and further smoothen out the load voltage and current signals. Equation (9) and (10) are the useful equations to compute the value of inductor and capacitor respectively.

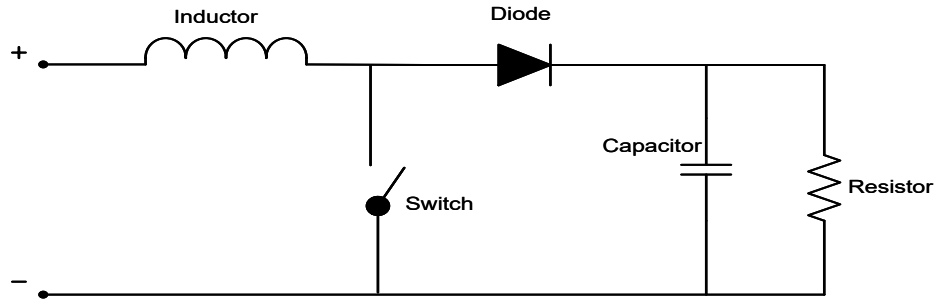

Figure 2. A DC-DC Boost Converter

Duty cycle,

$$D = 1 - (V_s/V_o) \quad (8)$$

Inductor,

$$L = (V_s D / \Delta i_o f) \quad (9)$$

Capacitor,

$$C = (V_o D / \Delta V_o R_f) \quad (10)$$

where,

V_s : Input voltage from solar PV

V_o : Output voltage at load side

Δi_o : Ripple output current

ΔV_o : Ripple output voltage

4. Design Variable Step Size P&O Algorithm

The operation for P&O algorithm is theoretically about perturbing or shifting the PV operation point based on the sign of the last increment of PV power [27], as presented in Figure 3(a). In other words, the operation point keeps increasing as the PV power increases. Once the PV power starts to decrease, the operation point goes in reversed direction. Eventually, it keeps oscillating around the MPP with a fixed step size. Figure 3(b) illustrates the operation for P&O algorithm towards the solar PV under constant irradiation [28].

Technically, larger step size contributes to higher power losses, since the tracked point is away from the real MPP. Therefore, to trim down the oscillation at the power peak, smaller step size is chosen for the P&O algorithm. Nevertheless, the transient response of the system is slow and influences the overall performance of solar PV. Besides, the conventional algorithm is unable to work well under various weather conditions, as wrong perturbation could happen and cause the operating point to move further away from the peak point. In short, these two conditions have become the critical drawbacks of the conventional P&O method.

Reference [29] proposed a voltage hold optimization of P&O method where an additional stage of decision is needed to verify the changes of irradiance level. The output of PV voltage (V_{PV}) is being hold until the irradiance variation is stop in order to avoid any wrong tracking direction. The step size is regularly decreased as the tracking is approaching MPP. The results depicted the applied system had low oscillations and real MPP was successfully obtained in real-time under various irradiance level.

Furthermore, the three points weight P&O method and two stage algorithm are suggested by reference [15] to prevent failing during rapid variation of irradiation. In fact, an instantaneous sampling and peak current control approaches that depend on the changes of reference current has also been recommended by reference [30, 31] to find a tradeoff between the weaknesses of P&O system.

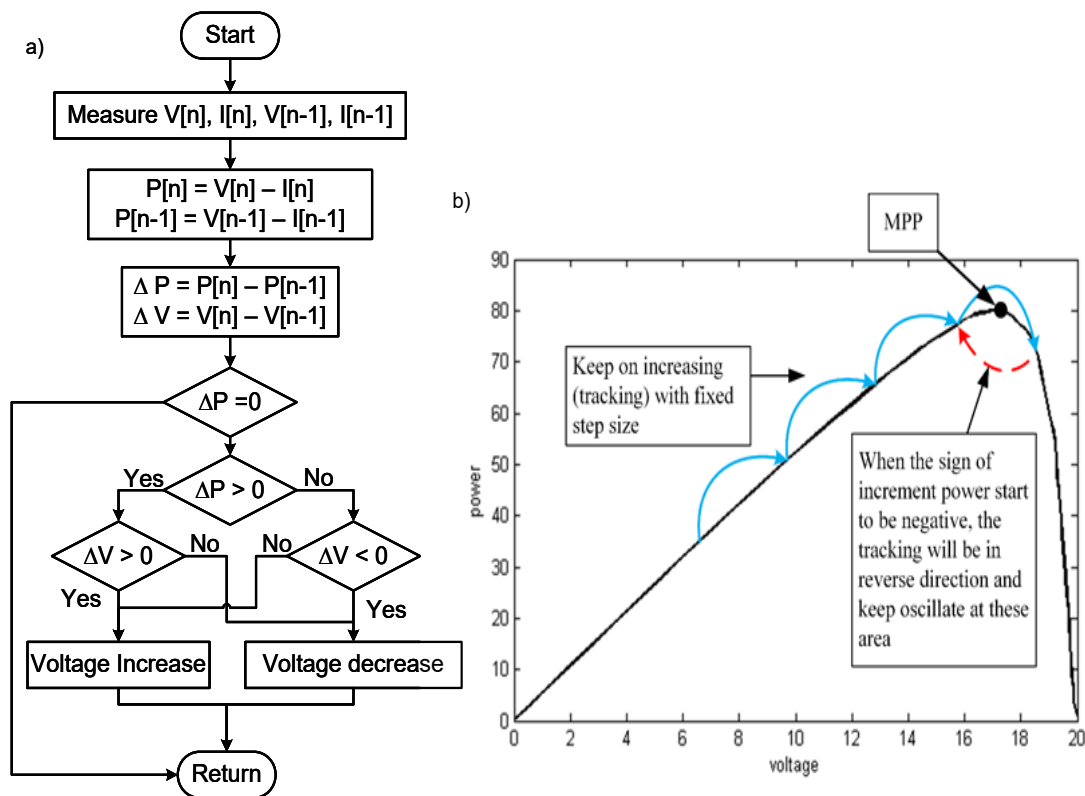

Figure 3. Operation for Perturb and Observe MPPT Technique (a) Flowchart for P&O Algorithm (b) P&O Tracking on the P-V Curve under Constant Irradiation

By referring all existed methods, this paper proposed a modified algorithm comes with three conditions, which are A, B and C, as seen in the flowchart (Figure 4). This method is basically combining the idea of having variable step size of P&O algorithm and principal of HC method. The Section A signifies the oscillation suppression stage. As the power peak is attained, the step size of the duty ratio is divided by a constant number, β , in order to reduce it to nearly zero and closer to the real MPP. The constant β is randomly picked as long as it is larger than 1. Since the real peak point is inconceivable to be achieved, a margin of power variation had been defined, which were from $-0.001W$ to $0.001W$. Then, stage A will be initiated as the condition is met.

Section B, as depicted in Figure 4 is utilized to sense the rapid variation of surrounding conditions. The idea comes from the I-V curve of the PV panel, as shown in Figure 5. The DC load line shown in the figure represents the equivalent resistance from the input at the specific value of duty long as ratio. From the figure, when the sun irradiation was $500 W/m^2$, the operating point was located at A. When the sun irradiation rapidly changed to $750 W/m^2$, the operating point changed and was located at point B. Therefore, it can be concluded that, the magnitude of PV current and PV voltage would either increase or decrease simultaneously when surrounding conditions change rapidly. Hence, from section B in Figure 4, a condition had been set, in order to sense the rapid changes, by which if the surrounding was subjected to rapid change, the whole algorithm would be initialized in order to obtain fast transient response.

In addition, Section C in Figure 4 provides the variable step size perturbation, whereby the value of step size, α is varied by dividing or multiplying α with 1.1 [32] depend on the value of the slope PV curve, $\Delta P/\Delta V$. As the slope of the curve decrease, this means that the operating point is approaching the MPP; as a result, the step size will automatically reduce so that an accurate MPP can be tracked.

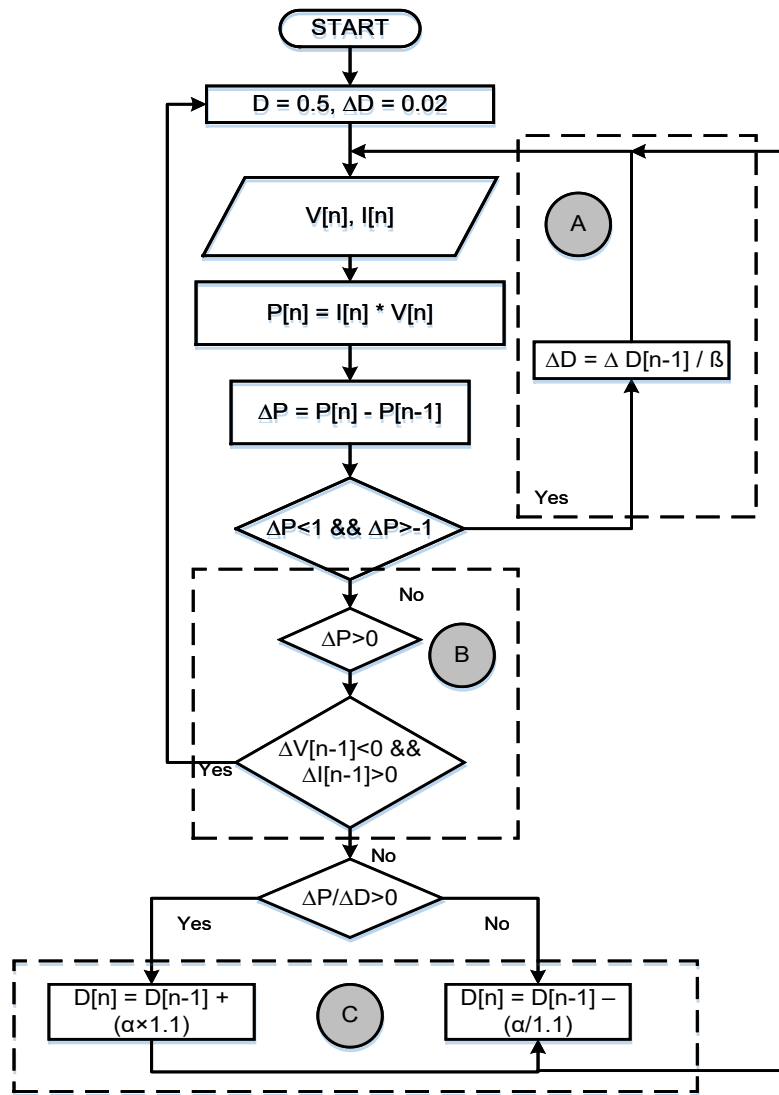

Figure 4. Proposed Modified P&O MPPT

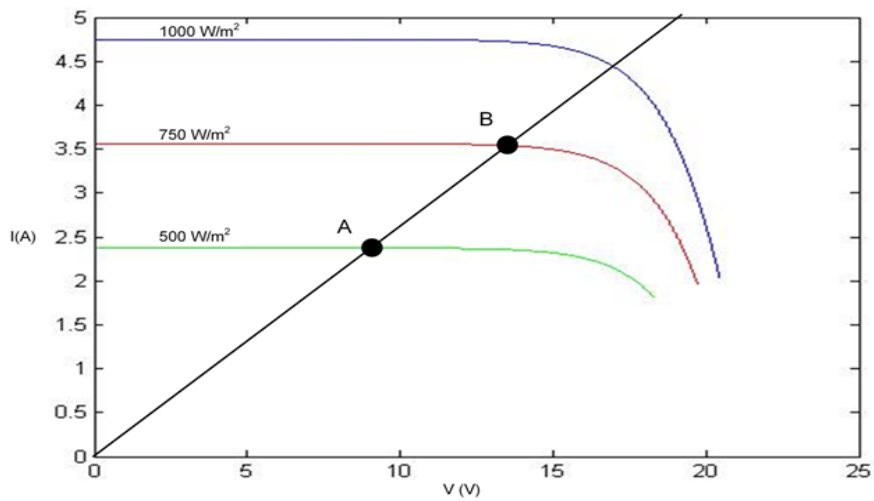

Figure 5. I-V Curve with DC Load Line [28]

5. Simulation (Matlab/Simulink)

The MPPT algorithm is implemented using MATLAB function block, while the Simpower system library is used to create the subsystem blocks for PV cell and boost converter. Simplified modelling circuit of PV cells is applied to analyse the characteristics of the panel. The basic layout of the MATLAB/Simulink is displayed in Figure 6.

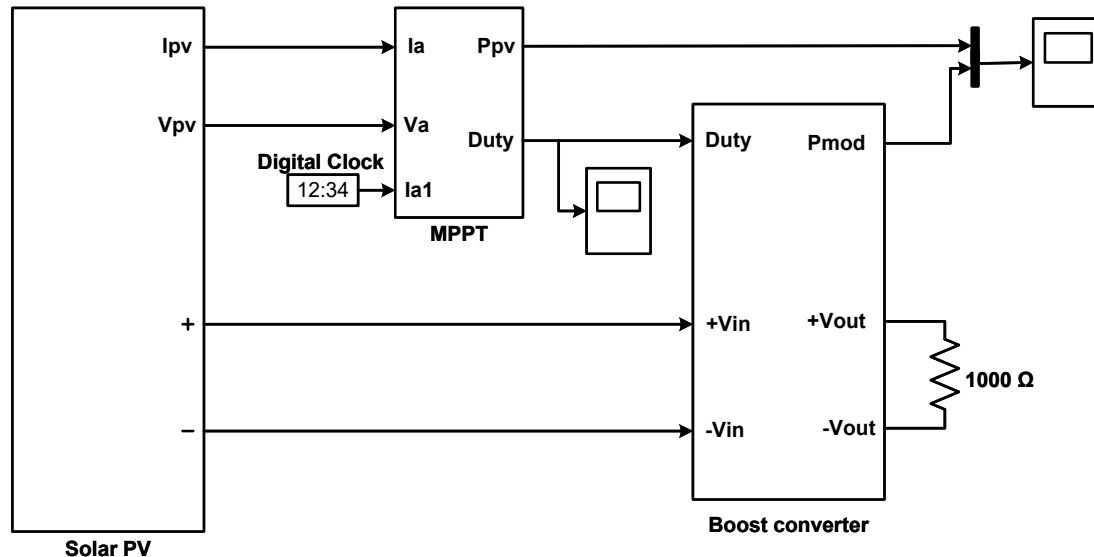

Figure 6. MATLAB/Simulink Layout

The proposed algorithm is placed at the MPPT block between the solar PV and boost converter which PV current and voltage (I_a and V_a) are the inputs while the duty cycle is the required output for the MPPT system. The parameters used for boost converter are: $220\mu\text{F}$ of capacitor, 30mH of inductor and 31kHz of switching frequency. Furthermore, a constant irradiation of 1000 W/m^2 and rapid change of irradiation from 800 W/m^2 to 1000 W/m^2 had been applied to the system. The result of the output power waveform was observed through the scope for comparison.

The simulation had been carried out with various step sizes; large step size, small step size and variable step sizes. The results of the solar cell power are presented in Figure 7(a), 7(b), 7(c) and 7(d), respectively. From the obtained results, there were some improvements shown by the variable step size over the conventional method (small or large step size). When small step size was used, although there was just a small oscillation during maximum power, the system's convergence speed was relatively slow, which took around 0.5s to be at the steady state. On the other hand, when the system was applied with large step size, the convergence speed had improved to 0.05s . However, the steady state oscillation became worse with the ripple power of 13 mW . Both cases demonstrated the general drawbacks of conventional P&O algorithm.

In order to solve this issue, variable step size algorithm was applied, with proven result as shown in Figure 7(c) regarding its efficiency and effectiveness. By using variable step size algorithm, convergence speed could be successfully maintained in 0.05s , while the oscillation was suppressed during steady state.

The system was also simulated under rapid changed of irradiation level from 800 W/m^2 to 1000 W/m^2 at simulation time of 1.0s , by using variable step size algorithm. The result of power curve is demonstrated in Figure 7(d). Result in Figure 7(d) shows the satisfying performance from variable step size P&O algorithm in dealing with rapid change of sun irradiation level.

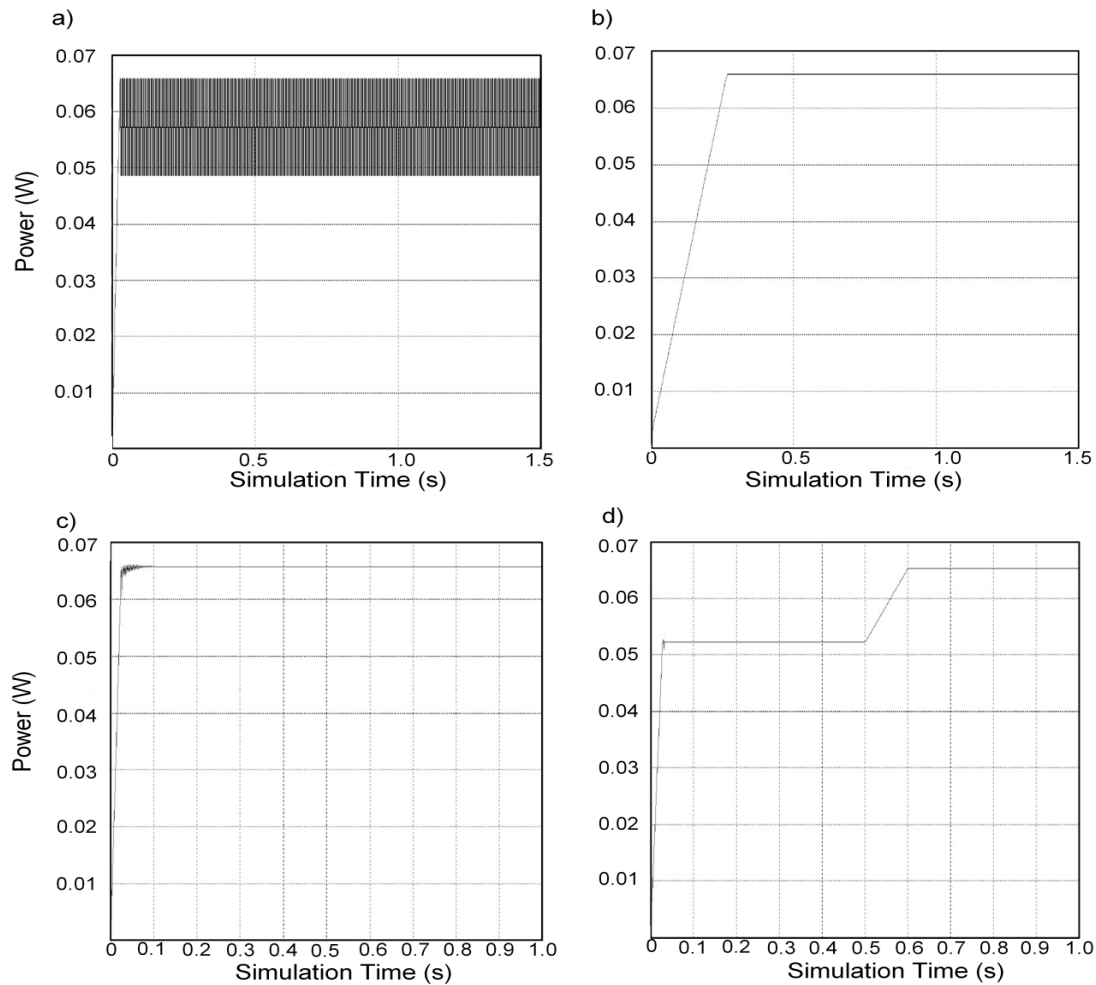

Figure 7. Solar Cell Power Curve with Different Step Size (a) Large Step Size (0.1V) (b) Small Step Size (0.01V) (c) Variable Step Size (d) Variable Step Size with Rapid Irradiance Variation

Figure 8(a), 8(b) and 8(c) depict the variation of duty cycle step size with respect to time for all three cases. Based on the figures, it can be concluded that, the optimum value of duty cycle was 0.65, in order to ensure the maximum output power to be extracted from the solar cell. As in Figure 8(c), the step size was automatically varied when the operating point approached the maximum peak power point.

From all three cases, the performance of the MPPT was carefully observed through the power curve from the output terminal of solar cell, as shown in 9(a), 9(b) and 9(c). In these figures, yellow colour line represents the output power from the solar cell terminal, while purple colour line represents the output power received by the load.

During the application of the small step size, the convergence speed was significantly slow, around 0.75s, with small oscillation at the maximum power point. In contrast, the convergence speed was improved from 0.75s to 0.3s when large step size was given to the system.

However, it contained a lot of ripple and oscillations, especially during steady state. Lastly, 9(c) demonstrates the power curve during the application of variable step size P&O algorithm. The figure clearly shows the improvement and promising performance delivered by this modified P&O algorithm, showing relatively faster convergence speed of 0.65s, small oscillation at steady state region and promising efficiency of 95.23%.

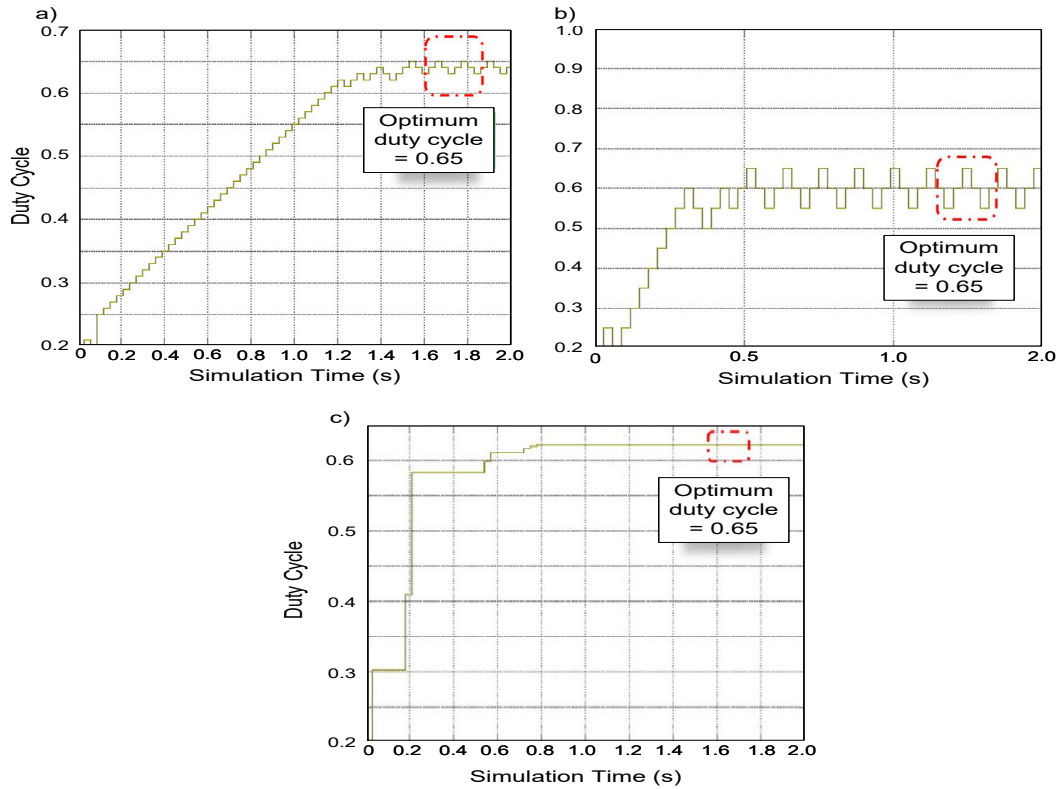

Figure 8. Duty Cycle with Different Step Size (a) Small Step Size (0.01V) (b) Large Step Size (0.05V) (c) Variable Step Size

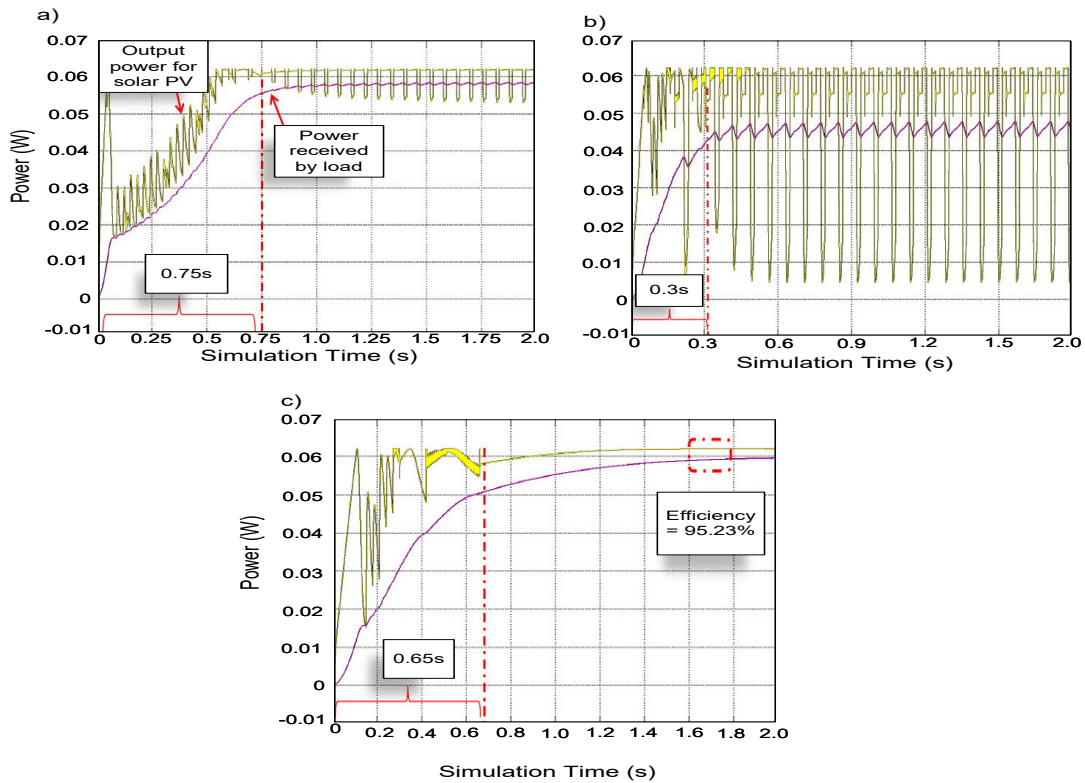

Figure 9. Power Curve at output cell terminal and load with Different Step Size (a) Small Step Size (0.01V) (b) Large Step Size (0.05V) (c) Variable Step Size

4. Hardware Implementation

Table 1 and 2 show the solar cell parameters and the list of components with its cost respectively. Solar cell was calibrated using potentiometer in order to have P-V and I-V curve. All the components were soldered onto donut board and a complete hardware prototype had been designed and constructed, as shown in Figure 10, with a box as a casing for better portability, an incandescent light bulb to represent sun irradiation and a light dimmer to adjust the irradiation level. The level of irradiation had been adjusted accurately with the aid of solar meter. Since it is impossible to follow the power curve at once from the oscilloscope, a software named Megunolink Plotting Tool was downloaded to plot the power curve, directly from hardware into the laptop.

Table 1. Solar Cell Parameter

Characteristic	Value
Peak Power (+/- 5%) P_{MPP}	0.065W
Rated Voltage V_{MPP}	2.7V
Rated Current I_{MPP}	0.023A
Open Circuit Voltage V_{OC}	3V
Short Circuit Current I_{SC}	0.024A
Temperature Coefficients' Power	-0.38 %/K
Temperature Coefficients' Voltage	-235.5 mV/K
Temperature Coefficients' Current	0.0013 mA/K
Band Gap (E_G)	11.12 eV
Ideality Factor (A)	1.6

Table 2. List of Components with Its Cost

Components	Quantity	Price (RM)
Solar Cell (3V)	1	6.50
MOSFET	1	2.00
Power Diode	1	4.00
Capacitor (220 μ F)	1	0.40
Resistor (1000 Ω)	1	0.05
Inductor (30mH)	1	2.50
MOSFET Driver (TC4427)	1	4.60
Arduino Mega 2560	1	160.00
Philips Light Bulb	1	2.00
Light Dimmer	1	16.00

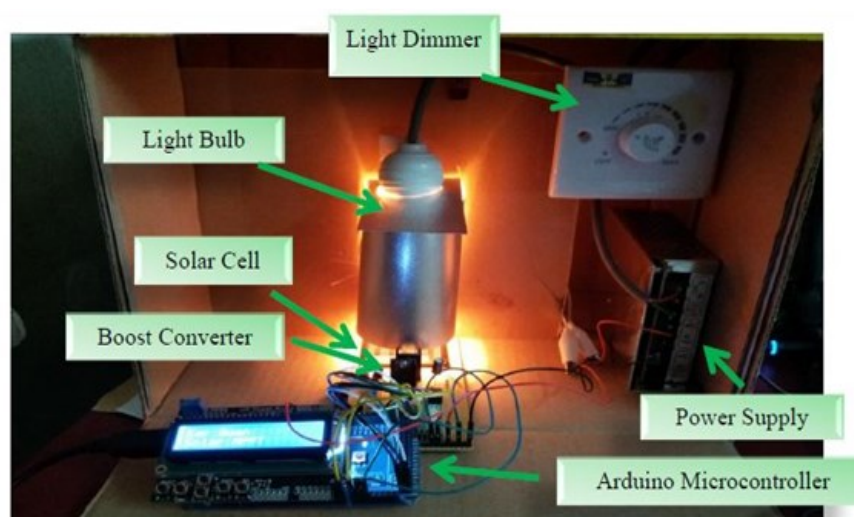

Figure 10. Complete Hardware Prototype

This software is compatible with the Arduino development board, with purpose that this software to receive the serial information that represents instantaneous power value from microcontroller through USB connection. Then, by using those data, a graph of power curve versus time can be plotted. Different step size had been used in this experiment (small, large and variable step size), whose results are displayed in Figure 11(a), (b) and (c) correspondingly.

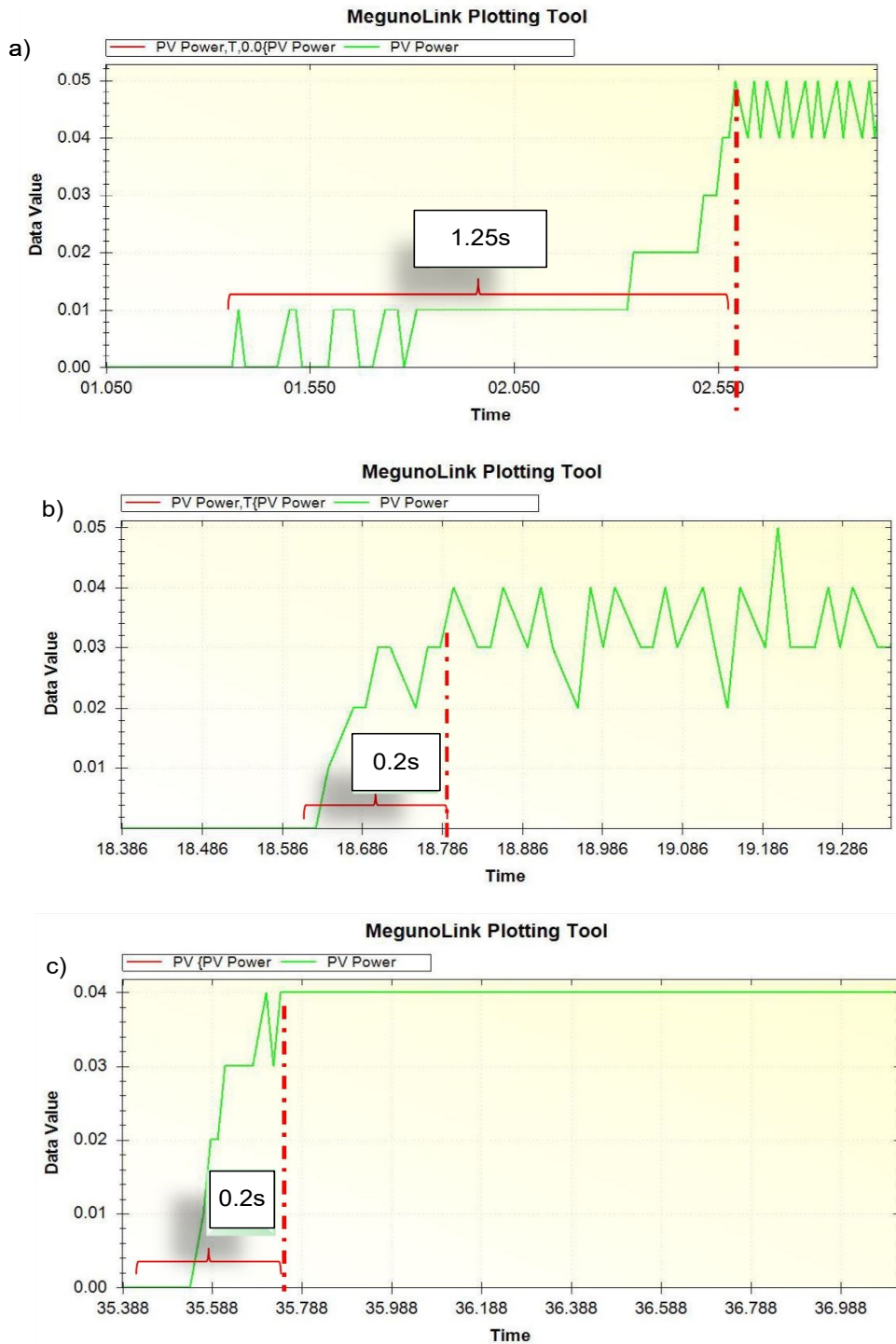

Figure 11. Power Curve with Different Step Size (Hardware Implementation) (a) Small Step Size (0.01V) (b) Large Step Size (0.05V) (c) Variable Step Size

The convergence time for the small step size was quite slow, which was approximately 1.25s, with small oscillation during maximum power. On the other hand, large step size showed an improvement by cutting the convergence time from 1.25s to 0.2s. Yet, the steady state oscillation was not acceptable.

Hence, by giving variable step size to the algorithm, the convergence time was able to maintain at 0.2s and give almost zero oscillation during steady state. Besides, the peak power tracked by algorithm corresponded with the reference value obtained during calibration, which was 47 mW, with small inconsistency.

4. Conclusion

Solar power application continues to reveal its potential as one of the reliable resources of renewable energy. However, lack of efficiency regarding its output power has become the major issue of the solar system. Thus, MPPT System is proposed to resolve this problem. This paper presents a simplified model of solar cell and a DC-DC boost converter, with some modifications to the conventional P&O algorithm, to enable the algorithm to track MPP under rapid change of irradiation and achieve balance between transient and steady state performance. Simulations by using MATLAB Simulink, as well as hardware prototype implementation, have been carried out along the experiment process. In hardware implementation, Arduino Mega2560 development board with ATmega2560 microcontroller chip have been utilized to provide Pulse Width Modulation (PWM) signal with updated duty cycle for MPPT purpose. The test results from both software and hardware highlight the common drawbacks of conventional P&O algorithm, in which, the quality of the transient and steady state performance cannot be guaranteed at the same time, as conveyed in the literature. Comparison between variable step size P&O and conventional P&O algorithm has been carried out, and according to the results obtained, it can be concluded that, the modified version of P&O algorithm can successfully compensate the disadvantages of conventional P&O, by providing fast convergence speed with small oscillation during steady state. After taking all the results into consideration, the modified version of P&O algorithm has proved itself as one of the best algorithms, in terms of simplicity, accuracy and efficiency.

Acknowledgement

The authors would like to thank Ministry of Education of Malaysia (MOE) and Universiti Teknologi Malaysia (UTM) for providing Research University Grant (RUG) under vote number Q.J130000.2523.07H82 for this research work.

References

- [1] Chihchiang Hua JL, Chihming Shen. Implementation of a dsp-controlled photovoltaic system with peak power tracking. *IEEE Transactions on Industrial Electronics*. 1998; 45(1): 99–107.
- [2] Chiu CS. Ts fuzzy maximum power point tracking control of solar power generation systems. *IEEE Transactions on Energy Conversion*. 2010; 25(4): 1123-1132.
- [3] Ouyang CSCaYL. Robust maximum power tracking control of uncertain photovoltaic systems: A unified ts fuzzy model-based approach. *IEEE Transactions on Control Systems Technology*. 2011; 19(6): 1516-1526.
- [4] Panigrahy PMKS. Analysis of characteristics curves of photovoltaic systems and mppt controllers under partial shading conditions. *Electronics and Instrumentation Engineering International Journal of Advanced Research in Electrical*. 2015; 4: 953–961.
- [5] Robinson FAF. *A variable step size perturb and observe algorithm for photovoltaic maximum power point tracking*. 47th International Universities Power Engineering Conference (UPEC). 2012; IEEE: 1-6.
- [6] Agarwal HPV. Matlab-based modeling to study the effects of partial shading on pv array characteristics. *IEEE Transactions on Energy Conversion*. 2008; 23(1): 302–310.
- [7] Eftichios Koutroulis KK, Nicholas C Voulgaris. Development of a microcontroller-based, photovoltaic maximum power point tracking control system. *IEEE Transactions on Power Electronics*. 2001; 16(1): 46–54.
- [8] Chen PC, Yan BS, Liu CL, Wang SC, Liu YH. *A comparative study on MPPT for photovoltaic generation systems*. 2nd International Future Energy Electronics Conference (IFEEEC). 2015; IEEE: 1-6.

- [9] Chapman TEPL. Comparison of photovoltaic array maximum power point tracking techniques. *IEEE Transactions on Energy Conversion EC*. 2007; 22(2): 439-449.
- [10] Gupta A. Solar Photovoltaics Engineering. A Power Quality Analysis Using Matlab Simulation Case Studies. Anchor Academic Publishing. 2016.
- [11] Hohm D, ME Ropp. *Comparative study of maximum power point tracking algorithms*. Progress in photovoltaics: Research and Applications. 2003; 11(1): 47-62.
- [12] Morales D. Maximum Power Point Tracking Algorithms for Photovoltaic Applications [Master's Thesis]. Aalto University, Faculty of Electronics, Communications and Automation. 2010.
- [13] Femia N, et al. Optimization of perturb and observe maximum power point tracking method. *IEEE transactions on power electronics*. 2005; 20(4): 963-973.
- [14] Thenkani A, NS Kumar. *Design of optimum Maximum Power Point Tracking algorithm for solar panel*. Computer, Communication and Electrical Technology (ICCCET). International Conference on. IEEE. 2011.
- [15] Elgendy MA, B Zahawi, DJ Atkinson. Assessment of perturb and observe MPPT algorithm implementation techniques for PV pumping applications. *IEEE transactions on sustainable energy*. 2012; 3(1): 21-33.
- [16] Jusoh A, et al. A Review on favourable maximum power point tracking systems in solar energy application. *TELKOMNIKA (Telecommunication Computing Electronics and Control)*. 2014; 12(1): 6-22.
- [17] Liu F, et al. A variable step size INC MPPT method for PV systems. *IEEE Transactions on industrial electronics*. 2008; 55(7): 2622-2628.
- [18] Messai A, et al. Maximum power point tracking using a GA optimized fuzzy logic controller and its FPGA implementation. *Solar energy*. 2011; 85(2): 265-277.
- [19] Chaouachi A, RM Kamel, K Nagasaka. A novel multi-model neuro-fuzzy-based MPPT for three-phase grid-connected photovoltaic system. *Solar energy*. 2010; 84(12): 2219-2229.
- [20] Tajuddin MFN, Arif MS, Ayob SM, Salam Z. Perturbative methods for maximum power point tracking (MPPT) of photovoltaic (PV) systems: a review. *International Journal of Energy Research*. 2015; 39(9): 1153-1178.
- [21] Gow J, C Manning. *Development of a photovoltaic array model for use in power-electronics simulation studies*. IEE Proceedings-Electric Power Applications. 1999; 146(2): 193-200.
- [22] Villalva MG, JR Gazoli, E Ruppert Filho. Comprehensive approach to modeling and simulation of photovoltaic arrays. *IEEE Transactions on power electronics*. 2009; 24(5): 1198-1208.
- [23] Ishaque K, Z Salam, H Taheri. Accurate MATLAB simulink PV system simulator based on a two-diode model. *Journal of Power Electronics*. 2011; 11(2): 179-187.
- [24] Kamarzaman NA, CW Tan. A comprehensive review of maximum power point tracking algorithms for photovoltaic systems. *Renewable and Sustainable Energy Reviews*. 2014; 37: 585-598.
- [25] Hart DW. Power electronics. Tata McGraw-Hill Education. 2011.
- [26] Durgadevi A, S Arulselvi, S Natarajan. *Study and implementation of Maximum Power Point Tracking (MPPT) algorithm for Photovoltaic systems*. IEEE, Electrical Energy Systems (ICEES), 1st International Conference on. 2011.
- [27] Femia N, et al. *Optimizing sampling rate of P&O MPPT technique*. in Power Electronics Specialists Conference. PESC 04. IEEE 35th Annual. 2004.
- [28] Piegari L, R Rizzo. *Adaptive perturb and observe algorithm for photovoltaic maximum power point tracking*. IET Renewable Power Generation. 2010; 4(4): 317-328.
- [29] Abdalla I, L Zhang, J Corda. *Voltage-hold perturbation & observation maximum power point tracking algorithm (VH-P&O MPPT) for improved tracking over the transient atmospheric changes*. in Power Electronics and Applications (EPE 2011), Proceedings of the 2011-14th European Conference on. 2011.
- [30] Pongratananukul N. *Analysis and simulation tools for solar array power systems*. University of Central Florida Orlando, Florida.
- [31] Petreuş D, et al. A novel maximum power point tracker based on analog and digital control loops. *Solar Energy*. 2011; 85(3): 588-600.
- [32] Jusoh AB, OJEI Mohammed, T Sutikno. *Variable step size Perturb and observe MPPT for PV solar applications*. TELKOMNIKA (Telecommunication Computing Electronics and Control). 2015; 13(1): 1-12.