

## Embedded System Practicum Module for Increase Student Comprehension of Microcontroller

Indrianto\*, Meilia Nur Indah Susanti, Rakhmat Arianto, Riki Ruli A. Siregar

Informatics Engineering, STT-PLN,  
Menara PLN, JL Lingkar Luar Barat Duri Kosambi Cengkareng Jakarta Barat 11750,  
Telp (021)5440342/5440344 ex.2114

\*Corresponding autor, email: indrianto\_basayev@yahoo.com; mnurindah@yahoo.com,  
arianto@sttpln.ac.id, ruliriki@gmail.com

### Abstract

*The result of applying the embedded system in education for students is successfully applied in university. On the other side, many people in Indonesia use smart equipment's (Hand phone, Remote), but none of those equipments are used in education. University as the source of knowledge should overcome the problem by encouraging the students to use a technology with learning about it first. Embedded System Practicum Module Design needs a prototype method so that the practicum module that is desired can be made. This method is often used in real life. A prototype considered of a part of a product that expresses logic and physical of external interface that is being displayed and this method will fully depend on user contentment. Embedded System Practicum Module Design is made to increase student comprehension of embedded system course and to encourage students to innovate, so that many technologies will be developed and also to help lecturers deliver course subjects. With this practicum it is hoped that the student comprehension will increase significantly. The result of this research is a decent practicum module,-hardware or software that can help students to know better about technology and the course subjects so that it will encourage the students to create an embedded system technology. The result of the test has been done; there is an increase of learning value obtained by 7.8%.*

**Keywords:** Module, Design, Embedded System, Student, Technology

**Copyright © 2018 Universitas Ahmad Dahlan. All rights reserved.**

### 1. Introduction

Embedded systems that covering an enormous span of applications, technology, and system scale, in three decades of teaching, is increasing amounts of the embedded computing material and successfully applied in Undergraduate Embedded System Education at Carnegie Mellon [1]. Developing tools that support model-based construction and delivery of sophisticated education that assists students and practioners master the complexity of developing embedded software and systems has been underway for several years, and it can be observed significant positive changes in the Vanderbilt University, America students give feedback, on the senior design project has been extremely positive [2]. The result of the student of University of Rio Grande do Norte, Brazil regarding the entire methodology employed in the class, it could be concluded that the Project-Based Learning Laboratory for Teaching Embedded Systems methodology was well received, since score 4 or 5 was given in more than 90%of the responses [3].

The development of computer world today is very rapid, particularly in Embedded-System based computer or microcontroller. It is shown by the inclusion of high-tech and intelligent equipments into everyday life. Such equipments are smart due to the existence of microcontroller and the programming system inside that is called Embedded System, which controls the performance of the equipment. Some example of embedded system equipment that we often see in everyday life are microwave ovens, air conditioners (AC), car alarms, children's toys, audio systems, mobile phones and many more.

In the world of academy, embedded systems still attract researchers to develop such as in research [4-8] where using servo as the core of research conducted, research [9-13] where in the research used the sensor as the core From a study demonstrating the implementation of a potentiometer, in a study [14-18] used DC motors as the core of the research undertaken, in a

study [19-21] using LEDs as the core of the research undertaken [22, 23] using the LCD as the core of the research undertaken. In addition to daily life, embedded systems are also used for specific purposes such as in research [24] using an embedded processor on Acid batteries as a source with Lithium Ion Capacitor.

Due to the importance of using embedded system on daily life, we research embedded system for students need to master or even create embedded system based equipment. To make this happen, especially the innovating part, university role is needed to encourage the students to grasp the concept of the technology then creating the technology itself.

For that reason, we research how to encourage students so that they can understand and create a technology. With the inclusion of embedded system in one of the courses at Informatics Engineering Sekolah Tinggi Teknik PLN, it felt easier for lecturer to encourage students to create the technology through a practicum. We create a student practicum module in both hardware and software, which will be used for the embedded system course. This practicum module is meant to help students on receiving subjects they're being lectured at. So that the students can get a better understanding with the subjects and it will be easier for them to create an embedded system based technologies. It is because they have learned it from theories and also practicums. With this practicum module, students can get a picture of what an embedded system is and how to use it. Aside from that, we also try to develop the subjects to avoid boredom in embedded system course.

## 2. Research Method

The Embedded System course is one of the courses in Sekolah Tinggi Teknik PLN. The teaching and learning activities of embedded system course only consist of theories, without practicum. In learning Embedded System, practicum is needed so that the students have better comprehension about it. Furthermore, the Embedded System course is a course that can give more skills to students, which can be a valuable when they graduate from Sekolah Tinggi Teknik PLN. Based on analyse and interview result, we will propose the practicum module that can overcome the problem that has been identified before, that is the absence of embedded system practicum module. To decide which research method is best, identification of problems is needed to be done beforehand. The illustration of the problem can be seen as such as shown in Figure 1.

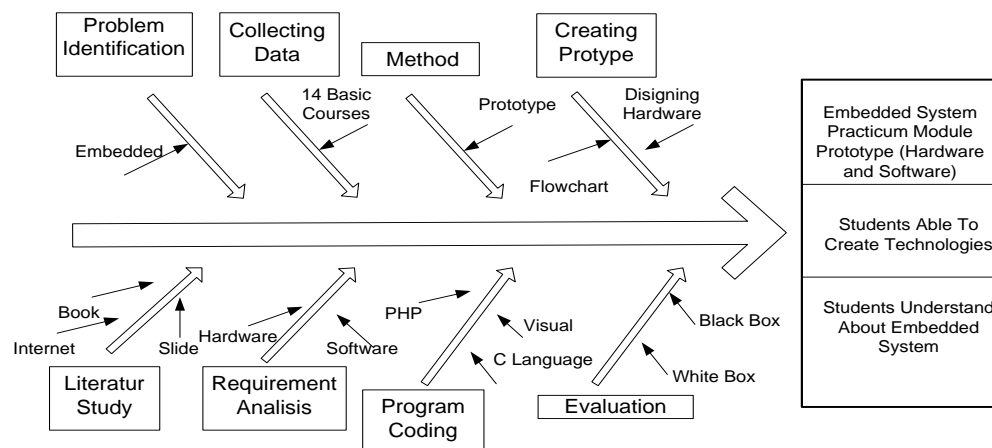

Figure 1. Research Method

The Figure 1 above shows that for students to understand the course of embedded systems and encouraged to create technology, it would require an experimental module that gives a real picture of these technologies so that students are not only getting theories from lecturers or just imagine it in their minds but students can also practice from theories. After students learn from practicum they will be given training projects and projects related to

embedded systems in the hope of innovations that will lead to the creation of technology among students. We also hope that students will be able to sell their products and obtain the patent of their creation. Thus the lab module is needed in the course of embedded systems, for it is necessary to create modules that will encourage students to understand and create technology.

The design used in this research is pre-experimental design of statistic group compared. The population used is the students of Informatics Engineering who have taken the course of electrical circuit in the final semester. With a sample consisting of 2 classes of class A and class B consisting of 45 students class A as experimental class given treatment and 45 students of Class B is non-experiment and not given treatment.

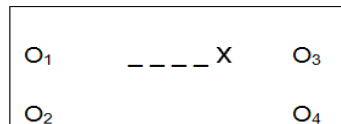

Figure 2. Static Group Comparison

Class group that is given treatment by using embedded system is a class of electric class A class Informatics engineering and class of electric class B class Informatics techniques are not given treatments. The technique that is being used for collecting data is by giving test sheets and questionnaires that are analyzed with Likert scale. With criterias such as “very helpful”, “helpful”, “enough”, “unhelpful”, “very unhelpful”.

Table 1. Criteria of Experiment

Percentages	Criteria
0%-20%	Very Unhelpful
21%-40%	Unhelpful
41%-60%	Enough
61%-80%	Helpful
81%-100%	Very Helpful

Based on the criteria percentages, embedded system module on helping students in increasing their comprehension of embedded system course is said to be good if it has a percentage above 60 percent.

$$\text{Percentage (\%)} = \frac{\text{Total Actual Score}}{\text{Total Ideal Score}} \times 100\% \quad (1)$$

### 3. Results and Analysis

#### 3.1. Design

The embedded system practicum module model design is implemented with arduino and its programming language. Here are some implementations that consist of hardware and software implementation.

##### 3.1.1. Potentiometer as Control Device

The purpose of this series is to obtain the results of increased student ability in understanding the servo motors by using LED indicators and using potentiometer sensors according to the specified program consissions.

The result of this module is to turn on LED, it the help of potentiometer as the control device. The LED lights will turn on one by one until all of it is on according to the input given by the potentiometer as the sensor so that the resulting data to rotate from the servo motor. With this module students can quickly understand in the use of sensors used for device control (servo motor) and students can understand the path of the signal used in assembling the embedded system series. The circuit in the embedded system is shown in Figure 3.

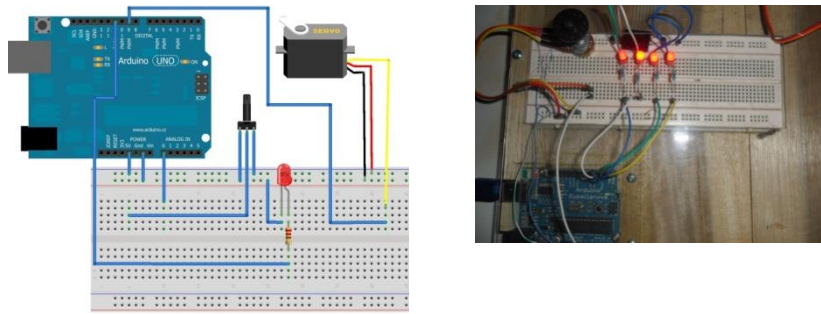

Figure 3. Design of Potentiometer as Control Device Design

The result of circuit testing in Figure 3 is obtained if the potentiometer does not move the LED indicator shows the value '0' (off) on each LED, and generated the degree on the servo motor by  $0^{\circ}$ . If given potentiometer value of 255 decimal, shows the value of LED 1 is 1 (on), and other LEDs are 0, and the resulting degree on the servo motor is  $45^{\circ}$ . If 510 decimal potentiometer is given the LED indicator shows LED 1 and LED 2 value is 1 (on), and Other LEDs are 0, and the resulting degree on the servo motor is  $90^{\circ}$ . If the potentiometer value is 765 decimal, the LED indicator shows LED 1, LED 2 and LED 3 values of 1 (on), and the other LEDs are 0, and the resulting degree on a motor servo of  $135^{\circ}$ . If a potentiometer value of 1023 decimal is given, the LED indicator shows the entire LED is 1 (on), and the resulting degree on the servo motor is  $180^{\circ}$ . Thus when given value 0 on potentiometer then the servo motor moves from the starting point. Similarly, when given a value of 255 on the potentiometer then the servo motor moves  $45^{\circ}$  from the starting point. Similarly, if given a value of 510 on the potentiometer then the servo motors move  $135^{\circ}$  from the starting point. Similarly, when given the value of 765 on potentiometer then the servo motor moves  $45^{\circ}$  from the starting point. Likewise, if given a value of 1023 on the potentiometer then the servo motor moves  $180^{\circ}$  from the starting point. The results of the test can be seen in Table 2.

Table 2. Result Program Logic of Potentiometer and Servo Control with indicator LED

Potentiometer	LED 1	LED 2	LED 3	LED 4	Degree Servo
0	0	0	0	0	0
255	1	0	0	0	45
510	1	1	0	0	90
765	1	1	1	0	135
1023	1	1	1	1	180

### 3.1.2. Servomotor with Keypad as Control Device on Arduino

The advantages of this module as well, students can understand that embedded systems can be given autotentication via a password with media keypad.



Figure 4. Result of Servomotor with Keypad as Control Device on Arduino Design

The result of servomotor with keypad as control device on arduino practicum module is to control the servomotor. The program that is embedded into the microcontroller is when button 1 on keypad is pressed, the servomotor will move to 10 degree position, when button 9 is pressed servo will move to 90 degree position and when button 0 is pressed servo will move to 0 degree position.

Table 3. Program Logic of Servomotor with Keypad as Control Device on Arduino

Keypad	Servo
0	0
1	10
9	90

Table 4. Result Program Logic of Keypad Work System on Arduino

Keypad	Serial Monitor
0	0
1	1
2	2
3	3
4	4
5	5
6	6
7	7
8	8
9	9
*	*
#	#

### 3.1.3. Understanding of Module Devices

Based on the results of the questionnaire calculations conducted on the arbitrariness of what do the student by using The Embedded system module. This can be seen from the graph below. With the graph and the questionnaire concluded that students are helping by The Embedded system. It is shown by the 89 respondents, 75,22% that said they could understand, learn, and operate the given module. The test results can be seen in Figure 5.

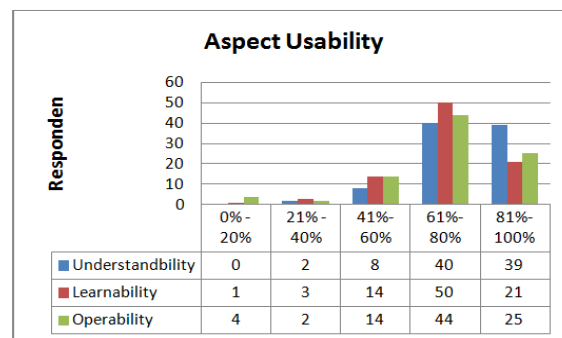

Figure 5. Aspect Usability

### 3.1.4. Testing of Respondents

Based on the results of tests conducted using pre-test and post-test it is seen that the class that provided the Embedded system module, has a much better average value compared to that not given the Embedded system module. In the test respondents conducted on 47 when done post-test get value equal to 64,7 and after doing post-test get value 72,5. From the results seen that there is an increase in the average value of the class, this is due to be given treatment in the form of implementation of embedded system module in class A. This can be seen in Figure 6.

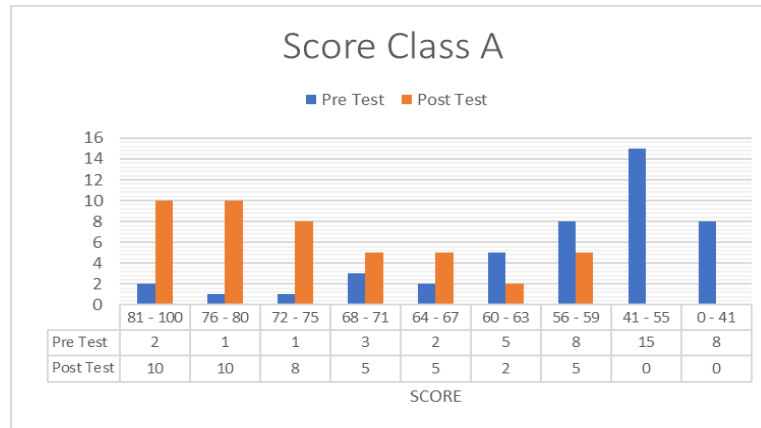

Figure 6. Class A Score

In the test of respondents conducted on 47 respondents in class B. In Class B when done post-test get value equal to 57,4 and after done post-test get value 57,8. From the results it can be seen that there is no increase in the average value of the class, this is due to not be given treatment in the form of implementation of embedded system module in class B. This can be seen in Figure 6.

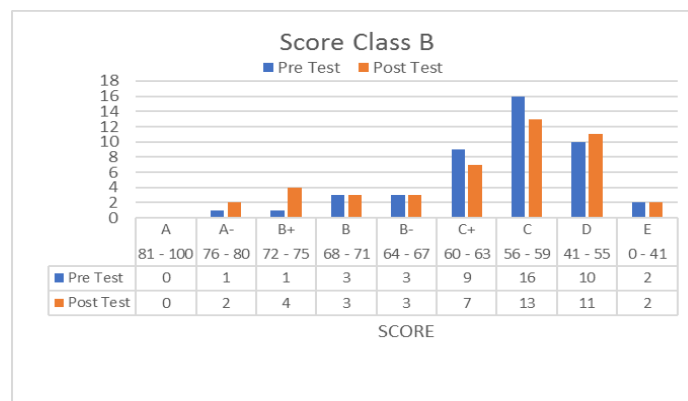

Figure 7. Class B Score

This also affects the research generated by students in the field of electricity is visible in the following table.

**4. Conclusion**

Result of potentiometer control device circuit used, student can see input value given by potentiometer, so that can be used to drive servo motor according to given data. The advantage of this module is that students can quickly understand the use of sensors used for device control (servo motors) and students can understand the signals used in assembling embedded systems. In Servomotor with Keypad, students can provide autotification via a password with media keypad on embedded system. Based on the test result and observation it can be concluded that embedded system practicum module can support the practicum activities so that students can get a better comprehension of embedded system and how embedded system applied in real world, so it will be easier to create technology. By using the embedded system Module the value obtained by the students increased by 7.8% from the previous value. Without this module, students will have difficulty upon applying embedded system theories into

electronic/component assembly. With this embedded system module practicum, we gain many advantages: Students can be easier to assemble the component, writing the program, run the program and observe the result of practicum, compare using the conventional method. Students can be independently on doing the practicum; it will be easier for practicum instructors in teaching how to practice what has been learned at embedded system course. Students got a better comprehension and able to implement it on technologies.

## References

- [1] P Koopman, et al. Undergraduate Embedded System Education at Carnegie Mellon. *ACM Trans. Embed. Comput. Syst.* 2005; 4(3): 500-528.
- [2] J Sztipanovits, et al. Introducing Embedded Software and Systems Education and Advanced Learning Technology in an Engineering Curriculum. *ACM Trans Embed Comput Syst.* 2005; 4(3): 549-568.
- [3] MAC Fernandes. Project-Based Learning Laboratory for Teaching Embedded Systems. *Math. Probl. Eng.* 2015; 2015: 8.
- [4] Y Wang, L Chen, Z Chen. A Fuzzy Selftuning Controlled Feeding Servo System of Machine Tool. *TELKOMNIKA (Telecommunication Computing Electronics and Control)*. 2013; 11(5): 2351-2358.
- [5] C Xian-gang, Z Jian-bin. Servo Motor Decoupling Control Based on PI Fuzzy Adaptive Method. *TELKOMNIKA (Telecommunication Computing Electronics and Control)*. 2013; 11(5): 2612-1618.
- [6] W Yeqin. Direct Drive Electrohydraulic Servo Control System Design with SelfTuning Fuzzy PID Controller. *TELKOMNIKA (Telecommunication Computing Electronics and Control)*. 2013; 11(6): 3374-3382.
- [7] X Xu, H Lin. Speed Loop Control Research of Roll Stable Servo Platform. *TELKOMNIKA (Telecommunication Computing Electronics and Control)*. 2013; 11(8): 4512-4516.
- [8] J Tian. Study on Control Strategy of ElectroHydraulic Servo Loading System. *TELKOMNIKA (Telecommunication Computing Electronics and Control)*. 2013; 11(9): 5044-5047.
- [9] R Khadim, M Erritali, A Maaden. Performance Study of IEEE 802154 under OPNET Modeler for Wireless Sensor Networks. *TELKOMNIKA (Telecommunication Computing Electronics and Control)*. 2015; 16(1).
- [10] S Chakkor. Performance Indicators for Wireless Intelligent Sensors Applications. *IJ-ICT International Journal of Informatics and Communication Technology*. 2014; 3(3).
- [11] J Rezaazadeh. Fundamental Metrics for Wireless Sensor Networks localization. *IJECE International Journal Electrical and Computer Engineering*. 2012; 2(4): 452-455.
- [12] H Azazi, MK Metwally, ZM El-Barbary. A Cost Effective sensorless vector control of 4 Switch 3Phase Inverter Fed IM using MRAS. *IJPEDS International Journal of Power Electronics and Drive Systems*. 2011; 1(2): 113-120.
- [13] CY Hsieh. Prediction of Forest Temperature Microchange by Wireless Sensor Network Technology. *IJECE International Journal Electrical and Computer Engineering*. 2012; 2(5): 632-638.
- [14] EP Mohanty, NK Mohanty. FPGA Based V/f Control of Three Phase Induction Motor Drives Integrating SuperLift Luo Converter. *IJPEDS International Journal of Power Electronics and Drive Systems*. 2015; 5(3): 393-403.
- [15] S Kaliappan, R Rajeswari. A Novel Approach of Position Estimation and Power Factor Corrector Converter Fed BLDC Motor. *IJPEDS International Journal of Power Electronics and Drive Systems*. 2015; 5(3): 415-423.
- [16] I Alsofyani, T Sutikno, Y Alamri, N Idris, N Nordin, A Wangsupphaphol. Experimental Evaluation of Torque Performance of Low Pass Filter and Extended Kalman Filter with Measured Torque for Induction Motor Drives. *IJPEDS International Journal of Power Electronics and Drive Systems*. 2015; 5(3): 433-440.
- [17] YK Lu. Adaptive Fuzzy Integral SlidingMode Regulator for Induction Motor Using Nonlinear Sliding Surface. *IJPEDS International Journal of Power Electronics and Drive Systems*. 2015; 5(4): 512-519.
- [18] M Elkholly, MA Elhameed. Braking of Three Phase Induction Motors by Controlling Applied Voltage and Frequency Based on Particle Swarm Optimization Technique. *IJPEDS International Journal of Power Electronics and Drive Systems*. 2015; 5(4): 520-528.
- [19] N Das, N Pal, P Sadhu. Design of Interior Daylighting Shading Control using LV and PVsyst Software. *TELKOMNIKA (Telecommunication Computing Electronics and Control)*. 2015; 14(3): 388-401.
- [20] M Rahman, M Haque, KD Kim. Indoor Positioning by LED Visible Light Communication and Image Sensors. *IJECE International Journal Electrical and Computer Engineering*. 2011; 1(2): 161-170.
- [21] P Yadav, N Pal, D Kumar, SV Krishna. LEDs Lighting Arrangements for Underground Mines. *TELKOMNIKA (Telecommunication Computing Electronics and Control)*. 2015; 15(1): 14-19.
- [22] JASM, H Guoqing. Nonuniform Defect Detection of Cell Phone TFTLCD Display. *TELKOMNIKA (Telecommunication Computing Electronics and Control)*. 2014; 12(8): 6036-6046.

- [23] L Zhi-hui, X Jinlong. The monochrome LCD Driver Design and Implementation Based on Framebuffer. *TELKOMNIKA (Telecommunication Computing Electronics and Control)*. 2013; 11(9): 4918-4924.
- [24] S Shanmugam, M Ramachandran. Design and Implementation of Embedded Processor Based Brushless Motor Drive using Lead Acid Battery as Source with Lithium Ion Capacitor. *TELKOMNIKA (Telecommunication Computing Electronics and Control)*. 2015; 14(3): 455-469.