

Foreign Tourist Arrivals Forecasting Using Recurrent Neural Network Backpropagation through Time

Wayan Oger Vihikan*, I Ketut Gede Darma Putra, I Putu Arya Dharmadi

Information Technology Department, Faculty of Engineering, Udayana University,
Bukit Jimbaran, Bali, Indonesia-803611, Telp/fax: (0361) 701954, 704845 / (0361) 701907

*Corresponding author, e-mail: ogervihikan@outlook.com

Abstract

Bali as an icon of tourism in Indonesia has been visited by many foreign tourists. Thus, Bali is one of the provinces that contribute huge foreign exchange for Indonesia. However, this potential could be threatened by the effectuation of the ASEAN Economic Community as it causes stricter competition among ASEAN countries including in tourism field. To resolve this issue, Balinese government need to forecast the arrival of foreign tourist to Bali in order to help them strategizing tourism plan. However, they do not have an appropriate method to do this. To overcome this problem, this study contributed a forecasting method using Recurrent Neural Network Backpropagation Through Time. We also compare this method with Single Moving Average method. The results showed that proposed method outperformed Single Moving Average in 10 countries tested with 80%, 70%, and 70% better MSE results for 1, 3 and 6 months ahead forecast respectively.

Keywords: Backpropagation Through Time, forecasting, tourism, Recurrent Neural Network

Copyright © 2017 Universitas Ahmad Dahlan. All rights reserved.

1. Introduction

The tourism industry is one of the huge industries that is growing very rapidly throughout the world. Many countries put the tourism sector as a strategic industry to increase revenue, including Indonesia, which has a great potential. Indonesia's tourism industry has become an important part of national development, as it can hold a lot of manpower, improve the local economy, and state revenues.

Bali as an icon of tourism in Indonesia and also as a world tourist destination that has a variety of art, culture and hospitality of the community has been visited by many foreign tourists. Data from Bali Tourism Office shows that since 2011 until 2015 the amount of foreign tourist arrivals to Bali is always increasing. For example, in 2011 the number of foreign tourist arrivals is 2,756,579, in 2012 it increased to 2,892,019, in 2013 it went up to 3,278,598, in 2014 it increased about 15% to 3,766,638 and in 2015 it climbed up to 4,001,835 [1]. In addition to that, Bali is the only province in Indonesia which has the highest amount of foreign tourist staying in star hotels since 2003 until 2015 [2]. Moreover, Bali won as the best island for holidaymakers and it is Bali's 12th times [3]. These make Bali as one of the provinces that contribute huge foreign exchange for Indonesia.

In the end of 2015, ASEAN Economy Community (AEC) was applied. This will cause strict competition among ASEAN countries in a lot of sectors including tourism. Indonesia as part of ASEAN had already prepared a presidential decree which ask local government to improve competitiveness in order to face AEC. It means Balinese government have a good opportunity to maintain and improve the amount of foreign tourist arrivals to Bali by promoting Bali's tourism intensively and improving Bali's tourism facilities. These can be achieved by strategizing Bali's tourism based on past data of foreign tourist arrivals which lead to forecasting to get overview of foreign tourist arrivals in the future.

The problem is Balinese government do not have an appropriate method to forecast foreign tourist arrival to Bali. Their forecast for the current year is based on the last year foreign tourist arrival growth with analysis of several factors such as political situation and natural disasters. To help overcome that problem, this paper proposed Recurrent Neural Network as forecasting method with Backpropagation Through Time as the training algorithm. Previous

researches using Recurrent Neural Network Backpropagation through Time show good results in forecasting time series data [4-7].

Therefore, the aims of this research is to contribute an accurate forecasting method of foreign tourist arrivals for Balinese government in order to anticipate the increase or decrease in foreign tourist arrivals to Bali. This will help Balinese government in setting up tourism facilities such as accommodation facilities (hotels, villas), infrastructure (roads, water, electricity), tourist attraction, restaurants, transportation, travel agencies, money changers and others.

2. Research Method

This research uses data of foreign tourist arrivals to Bali and their factors. The factors of foreign tourist arrivals are population of origin country, Gross Domestic Product (GDP) real of origin country and Consumer Price Index (CPI) in Indonesia relative to CPI of origin country [8]. Those data are taken from 2005 to 2015 and has time series characteristic. Time series data is a set of data generated sequentially in time [9].

Before beginning the process, the data have to be normalized and scaled to range between -1 and 1 using equation below. Then, the data is divided into 2 parts, those are training and test data.

$$\hat{x} = \frac{(x - \minVal) * (\maxRange - \minRange)}{(\maxVal - \minVal)} + \minRange \quad (1)$$

With:

- x : Original data.
- \hat{x} : Normalized data.
- \maxVal : The maximum value of original data.
- \minVal : The minimum value of original data.
- \maxRange : The maximum value of normalized data (1).
- \minRange : The minimum value of normalized data (-1).

Recurrent Neural Network is adapted from standard feed forward neural network that can model sequential data [10]. It allows the network to map from all previous inputs to each output [11]. It is easier to understand by looking to unfolded RNN in Figure 1, where previous time step is needed to calculate current time step which is shown as t-1 and t respectively. RNN BPTT is started by doing Forward Propagation process. This process will calculate the network output from the input data given using equation below [10].

$$h_t = \tanh(Ux_t + Wh_{t-1} + b_h) \quad (2)$$

$$o_t = \tanh(Vh_t + b_o) \quad (3)$$

With:

- h_t : Hidden state at time step t.
- U : Input to hidden state weight matrix.
- x_t : Input vector at time step t.
- W : Hidden to previous hidden state (recurrent) weight matrix.
- h_{t-1} : Hidden state at previous time step.
- b_h : Bias at hidden state.
- V : Hidden state to output weight matrix.
- b_o : Bias at output state.

After that the loss between network's output and targeted output is calculated. In this case Mean Squared Error is used as the loss function. If the value close to 0, it means the network and targeted output or factual data value are close.

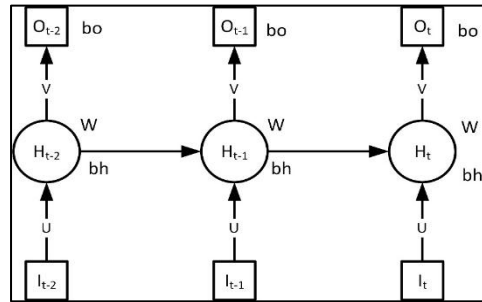

Figure 1. Unfolded Recurrent Neural Network

$$L = \frac{1}{2N} \sum_{i=1}^N (\hat{o}_i - o_i)^2 \quad (4)$$

With:

- L : Loss value.
- N : The amount of training data.
- \hat{o} : Network's output.
- o : Targeted output.

Each of the weight matrices have to learn from the error (loss). This can be achieved by updating each weight matrices for each training data using Stochastic Gradient Descent. To do that, first Backpropagation Through Time should be applied. This algorithm calculates the gradient of loss function with respect to each weight matrix as formula below.

$$\frac{\partial L}{\partial V} = \frac{\partial L}{\partial \hat{o}} \frac{\partial \hat{o}}{\partial z} \frac{\partial z}{\partial V} \quad (5)$$

$$\frac{\partial L}{\partial b_o} = \frac{\partial L}{\partial \hat{o}} \frac{\partial \hat{o}}{\partial z} \frac{\partial z}{\partial b_o} \quad (6)$$

$$\frac{\partial L}{\partial W} = \sum_{t=0}^T \frac{\partial L}{\partial \hat{o}} \frac{\partial \hat{o}}{\partial z} \frac{\partial z}{\partial h_T} \frac{\partial h_T}{\partial h_t} \frac{\partial h_t}{\partial W} \quad (7)$$

$$\frac{\partial L}{\partial b_h} = \frac{\partial L}{\partial \hat{o}} \frac{\partial \hat{o}}{\partial z} \frac{\partial z}{\partial h_T} \frac{\partial h_T}{\partial b_h} \quad (8)$$

$$\frac{\partial L}{\partial U} = \sum_{t=0}^T \frac{\partial L}{\partial \hat{o}} \frac{\partial \hat{o}}{\partial z} \frac{\partial z}{\partial h_T} \frac{\partial h_T}{\partial h_t} \frac{\partial h_t}{\partial U} \quad (9)$$

With:

- z : Network's output before activation function (tanh) is applied.
- T : Current time step.

Finally, each weight matrix is updated with BPTT calculation results and learning rate. In order to avoid over-fitting and improve generalization, weight decay is used by multiplying each weight with regularization parameter before updating them [12]. The new weight matrices value will be used in the next time step. Formula for updating weight matrix is shown below.

$$U = U - \eta * \left(\frac{\partial L}{\partial U} + \lambda U \right) \quad (10)$$

$$W = W - \eta * \left(\frac{\partial L}{\partial W} + \lambda W \right) \quad (11)$$

$$b_h = b_h - \eta * \frac{\partial L}{\partial b_h} \quad (12)$$

$$V = V - \eta * \left(\frac{\partial L}{\partial V} + \lambda V \right) \quad (13)$$

$$b_o = b_o - \eta * \frac{\partial L}{\partial b_o} \quad (14)$$

With:

η : Learning rate.
 λ : Regularization parameter.

All these processes are repeated for all training data and epoch. The test will be done by using test data and final weight matrices of training process into Forward Propagation process. Mean Squared Error will be used to see how good the network output when tested using test data.

Single Moving Average is a statistic method that can be used to forecasting time series data. It works by calculating the mean of a constant number of observations in a sliding time span and it will smooth the irregular fluctuation of data. The number of observations used is called the order of the series [13]. Previous researches showed that Single Moving Average can be used to forecast time series data [14-15]. In this research Single Moving Average with order 2 or SMA(2) is used and calculated with formula below.

$$MA(2) = \sum_{t=t_1}^{t_2} x_t \quad (15)$$

With:

x_t : Number at index t.

3. Results and Analysis

There are 132 monthly data of foreign tourist arrival and 11 annual data for each foreign tourist arrival factor for each country which is taken from 2005 until 2015. Foreign tourist arrival factor data are divided by 12 to get the mean value for each month. All these data are divided into training and test data after normalizing process. There are 3 types of forecasting time period tested in this research, those are 1, 3, and 6 months ahead. Each time period has different amount of training data. Forecasting 1, 3, and 6 months ahead are done using 119, 117 and 114 data respectively and then tested using 12 data outside of the training data.

Web based application written in PHP and HTML is made to implement RNN BPTT and SMA(2) method. This application will train and test the network and showed the comparison results between those 2 methods and target data in chart form as shown in Figure 2 to 6.

The network consists of 4 input states where each of them represents input for foreign tourist arrivals, population of origin country, GDP of origin country and CPI of Indonesia relative to CPI of the origin country. There is 1 hidden layer with specified number of hidden state. The number of output state depends on the time period of forecasting, for example forecasting 3 months ahead will use 3 output states.

There are 36 network test configuration for each time period. The configuration variables are the amount of hidden state, number of epoch and learning rate. The number of hidden states are 5, 10 and 15. The number of epoch are 300, 400, and 500 and learning rate is 0.01, 0.05, 0.1, and 0.5. In Backpropagation Through Time process, truncated backpropagation is applied. It reduced the calculation cost because it only calculates k_2 timesteps [16]. In this research k_2 is 2, so the backpropagation process will calculate up to 2 time step only. Each of network configuration results are compared with Single Moving Average results in MSE form.

There are 10 countries tested, they are Australia, China, Malaysia, Japan, Singapore, South Korea, United Kingdom, United State of America, France and Germany. These are top 10 countries with highest foreign tourist arrival to Bali since 2011 to 2015 [1].

Table 1, 2, and 3 show the best network configuration with the smallest RNN BPTT MSE compared with SMA(2) MSE when testing those methods to forecast foreign tourist arrival to Bali. Table 1 shows the comparison between test data MSE of RNN BPTT and SMA with order 2 in 1 month ahead forecast. The comparison reveals that Australia, China, Malaysia, Japan, Singapore, South Korea, France and Germany RNN BPTT MSE are smaller than

SMA(2) MSE. This means 8 out of 10 countries or 80% of them gives better results when tested using RNN BPTT method.

Table 1. Test results of 1 month ahead forecast

Country	1 Month Ahead Forecast				
	Hidden State	Epoch	RNN BPTT		SMA(2)
			Learning Rate	MSE of RNN BPTT Test Data	MSE of SMA(2) Test Data
Australia	5	500	0.1	0.04835	0.08901
China	15	300	0.1	0.07835	0.09859
Malaysia	10	300	0.01	0.04479	0.09926
Japan	15	400	0.1	0.02358	0.03688
Singapore	10	300	0.01	0.06471	0.15260
South Korea	5	300	0.5	0.05690	0.10034
UK	10	400	0.01	0.09694	0.08209
USA	5	300	0.5	0.05883	0.05565
France	10	500	0.01	0.06447	0.08900
Germany	15	300	0.05	0.06988	0.09709

Table 2. Test results of 3 months ahead forecast

Country	3 Months Ahead Forecast				
	Hidden State	Epoch	RNN BPTT		SMA(2)
			Learning Rate	MSE of RNN BPTT Test Data	MSE of SMA(2) Test Data
Australia	5	300	0.1	0.04083	0.07674
China	10	300	0.1	0.07025	0.09814
Malaysia	15	300	0.01	0.06534	0.09826
Japan	15	300	0.1	0.02654	0.03303
Singapore	15	400	0.01	0.09591	0.15136
South Korea	5	300	0.5	0.05893	0.10125
UK	15	400	0.01	0.11138	0.06971
USA	5	300	0.5	0.06250	0.05087
France	10	400	0.01	0.07302	0.08615
Germany	5	400	0.1	0.10328	0.08465

Table 2 shows the comparison between test data MSE of RNN BPTT and SMA with order 2 in 3 months ahead forecast. The comparison reveals that Australia, China, Malaysia, Japan, Singapore, South Korea and France RNN BPTT MSE are smaller than SMA(2) MSE. This means 7 out of 10 countries or 70% of them gives better results when tested using RNN BPTT method.

Table 3. Test results of 6 months ahead forecast

Country	6 Months Ahead Forecast				
	Hidden State	Epoch	RNN BPTT		SMA(2)
			Learning Rate	MSE of RNN BPTT Test Data	MSE of SMA(2) Test Data
Australia	5	400	0.5	0.03370	0.05587
China	15	300	0.1	0.06417	0.09589
Malaysia	15	300	0.01	0.06969	0.09785
Japan	5	500	0.01	0.02304	0.02689
Singapore	10	400	0.1	0.07845	0.15263
South Korea	15	300	0.5	0.05356	0.08929
UK	5	400	0.01	0.09568	0.05388
USA	10	400	0.01	0.04830	0.04301
France	10	500	0.01	0.05771	0.09155
Germany	5	500	0.1	0.08870	0.06597

Table 3 shows the comparison between test data MSE of RNN BPTT and SMA with order 2 in 6 months ahead forecast. The comparison reveals that Australia, China, Malaysia, Japan, Singapore, South Korea and France RNN BPTT MSE are smaller than SMA(2) MSE. This means 7 out of 10 countries or 70% of them gives better results when tested using RNN BPTT method.

Figure 2, 3, 4, 5 and 6 show one of test data result of first 5 countries tested in chart form that represent forecast test comparisons of foreign tourist arrival to Bali by RNN BPTT, SMA(2) and real data. The green line represents real data, pink line represents RNN BPTT forecast and blue line represents SMA(2) forecast. The values of tourist arrivals are still in range between -1 to 1.

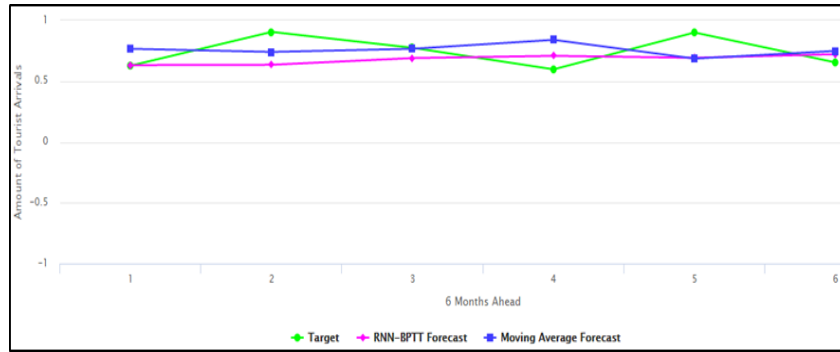

Figure 2. Forecast comparison chart between RNN BPTT, SMA(2), and real data of Australia

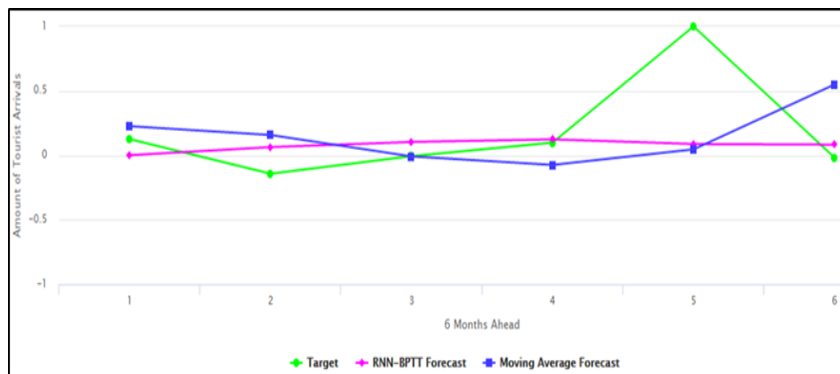

Figure 3. Forecast comparison chart between RNN BPTT, SMA(2), and real data of China

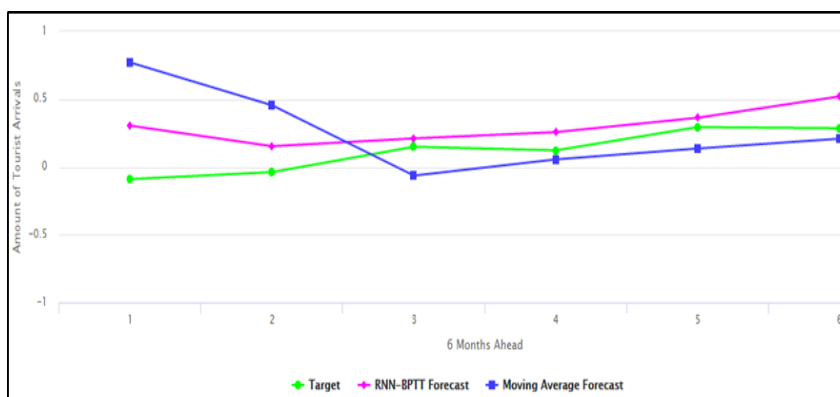

Figure 4. Forecast comparison chart between RNN BPTT, SMA(2), and real data of Malaysia

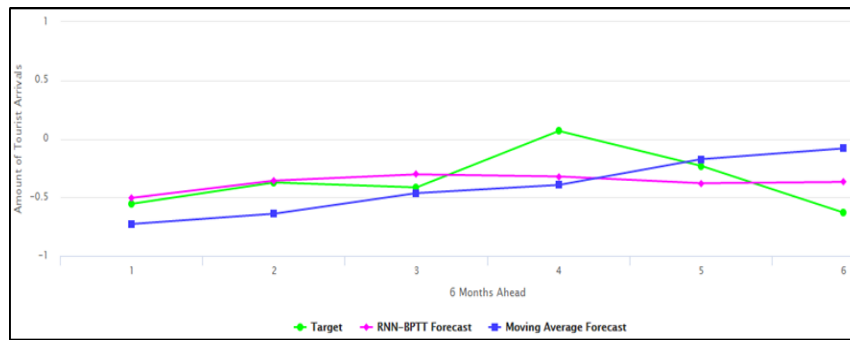

Figure 5. Forecast comparison chart between RNN BPTT, SMA(2), and real data of Japan

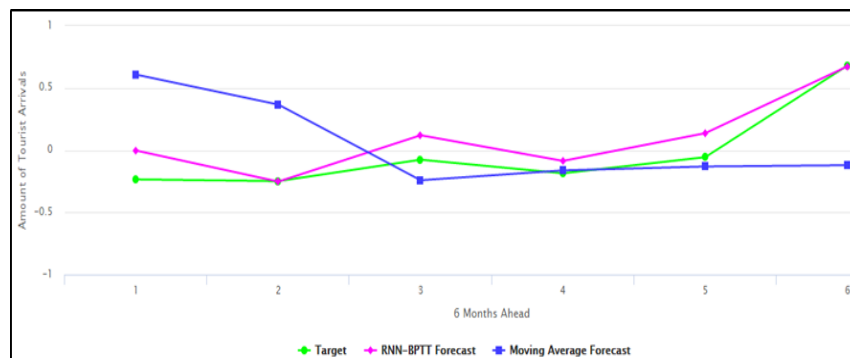

Figure 6. Forecast comparison chart between RNN BPTT, SMA(2), and real data of Singapore

4. Conclusion

Based on the research results can be concluded some points as following:

1. Recurrent Neural Network Backpropagation Through Time can be used as forecasting method of foreign tourist arrival to Bali by Balinese government due to the forecast test results for most countries tested in 1, 3, and 6 months ahead forecast are closer to factual data than Single Moving Average method's which is shown by their MSE value.

2. From 10 countries tested, 80% MSE of RNN BPTT for 1 month ahead forecast is smaller than MSE of SMA(2). For 3 and 6 months ahead forecast, 70% MSE of RNN BPTT is smaller than SMA(2). The smaller the MSE means the forecast test results are closer to factual data. These mean Recurrent Neural Network Backpropagation Through Time method outperformed Single Moving Average order 2 in forecasting foreign tourist arrival to Bali.

References

- [1] Statistik-Disparda Bali. The Number of Foreign Tourists Arrival to Bali by Month 2008 – 2017. Denpasar: Dinas Pariwisata Provinsi Bali. 2017.
- [2] Badan Pusat Statistik. Jumlah Tamu Asing pada Hotel Bintang Menurut Provinsi, 2003-2015 (Ribuan). Jakarta: Badan Pusat Statistik. 2017.
- [3] DestinAsian Magazine. DestinAsian 2017 Reader's Choice Awards. Singapore: DestinAsian Media Group. 2017.
- [4] Fang C, Wang X, Murphey YL, Weber D, MacNeille P. *Specific Humidity Forecasting using Recurrent Neural Network*. International Joint Conference on Neural Networks (IJCNN). Beijing. 2014: 955-960.
- [5] Vlahogianni EI, Karlaftis MG. Testing and Comparing Neural Network and Statistical Approaches for Predicting Transportation Time Series. *Transportation Research Record: Journal of the Transportation Research Board*. 2013; 2399(1): 9-22.
- [6] Cao Q, Ewing BT, Thompson MA. Forecasting Wind Speed with Recurrent Neural Networks. *European Journal of Operational Research*. 2012; 221(1): 148-154.

-
- [7] Saini SS, Parkhe O, Khadtare TD. Analysis of Feedforward and Recurrent Neural Network in Forecasting Foreign Exchange Rate. *Imperial Journal of Interdisciplinary Research (IJIR)*. 2016; 2(6): 822-826.
- [8] Hertinmalyana M. *Analysis of Demand and Consumption of International Visitors to Indonesia (from selected countries)*. 13th Global Forum on Tourism Statistics. Nara. 2014.
- [9] Rawat KS, Massiha GH. Hardware Implementation of FIR Neural Network for Applications in Time Series Data Prediction. *Indonesian Journal of Electrical Engineering and Computer Science*. 2015; 14(1): 130-139.
- [10] Sutskever I, Martens J, Hinton GE. *Generating Text with Recurrent Neural Networks*. Proceedings of the 28th International Conference on Machine Learning. Bellevue. 2011; 11: 1017-1024.
- [11] Graves A. Supervised Sequence Labelling with Recurrent Neural Networks. New York: Springer. 2012: 22.
- [12] Krogh A, Hertz JA. *A Simple Weight Decay Can Improve Generalization*. Advances in Neural Information Processing Systems 4. Denver. 1992: 950-957.
- [13] Yaffee RA, McGee M. Introduction to Time Series Analysis and Forecasting with Applications of SAS and SPSS. San Diego: Academic Press. 2000: 18-19.
- [14] Ekawati N. Prediction of Poor Inhabitant Number Using Least Square and Moving Average Method. *Indonesian Journal of Electrical Engineering and Computer Science*. 2015; 16(2): 369-376.
- [15] Pal A, Singh JP, Dutta P. *The Path Length Prediction of MANET using Moving Average Model*. International Conference on Computational Intelligence: Modeling Techniques and Applications (CIMTA). Kolkata. 2013; 10: 882-889.
- [16] Sutskever I. Training Recurrent Neural Networks. PhD Thesis. Toronto: University of Toronto; 2013.