

## Wideband Multi-Port Reflectometer as an Alternative in Reflection Coefficient Measurement

Rashidah Che Yob, Norhudah Seman\*

Wireless Communication Centre (WCC), Faculty of Electrical Engineering, Universiti Teknologi Malaysia,  
81310 UTM Johor Bahru, Johor, Malaysia

\*Corresponding author, e-mail: huda@fke.utm.my

### Abstract

*This paper presents the characterization and operation of an alternative device, which is known as multi-port reflectometer to measure the reflection coefficient of any device under test (DUT). Its configuration is formed by two power dividers (D) and four couplers (Q). The characterization is evaluated through the centres of power circles that also known as q-points. Its operation in the reflection coefficient measurement is tested by using three DUTs. The reflectometer's good performance and wideband operation are proven between the frequency band of 1 and 6 GHz via the practical hardware measurement in the laboratory.*

**Keywords:** Coupler, multi-port reflectometer, power divider, reflection coefficient, wideband

Copyright © 2017 Universitas Ahmad Dahlan. All rights reserved.

### 1. Introduction

The determination of a ratio of two complex signals; one incident and the other one reflected which known as the complex reflection coefficient is required over a specific frequency band in many microwave applications. Particularly, one of the most frequently used as the microwave measurement instruments is a Vector Network Analyzer (VNA), where such task can be performed. Depending on the heterodyning receiver technique, an accurate measurement of the reverse and forward of the scattering parameters of any microwave device under tests (DUTs) is offered by this measurement instrument [1-5]. Unfortunately, this instrument is bulky, very expensive and has limited use in some laboratory environments only [1-5]. Meanwhile, the demand of many applications today requires simple, compact-size and low-cost measurement solution. Therefore, a wideband multi-port reflectometer, which is formed by only passive devices of power dividers (D), and couplers (Q) is proposed to be used in determining the reflection coefficient of the device under test (DUT) as an alternative measurement instrument to the common VNA. Wideband multi-port reflectometer has two input ports provided to a power source and DUT, and also having at least three outputs ports terminated in scalar power detectors. Where, this passive linear circuit can be used to acquire the microwave parameters of voltage, phase, impedance and complex reflection coefficients of active or passive DUT [1-5]. The advantage of the wideband multi-port reflectometer is that it can produce phase characteristic of DUT by only making scalar power measurements, where the requirement of the phase information on the output ports can be ignored.

Furthermore, in its operation; which is opposite to VNA, the frequency down-conversion is not required. Therefore, with this measurement technique of multi-port; the cost of the equipment will be reduced, and the hardware requirements also will be facilitated. Besides that, it has another advantage of lower frequency sensitivity, which not requires frequent calibration that promises long-term stability to the operation [1-5].

### 2. Design of Multi-Port Reflectometer

In this paper, the configuration of the proposed wideband multi-port reflectometer is illustrated in Figure 1, which consists of two power dividers (D) and four couplers (Q) [5]. Referring to this configuration, a microwave source is connected to Port 1 and device under test (DUT) is connected to Port 2, where it acts as a measurement port. The variable  $a$  represents a

reflected signal, and the variable  $b$  indicates an incident signal to DUT. Meanwhile, the required information on the measurement is obtained from Port 3 to 7, which terminated by five scalar power detectors. Port 3 is used as the reference for the purpose to monitor the power level of the source signal. The constant power level can be maintained through a feedback loop by monitoring the power measured at Port 3. The enclosed broken line part of the wideband multi-port reflectometer in Figure 1 is known as complex ratio measuring unit (CRMU), which also can be known as a correlator [6–7]. The CRMU is the heart of the wideband multi-port reflectometer where it is formed by a power divider and three couplers. It plays a common role similar to the complex ratio detector (CRD) based on the heterodyne receiver technique in the conventional vector network analyzer (VNA) [6–7].

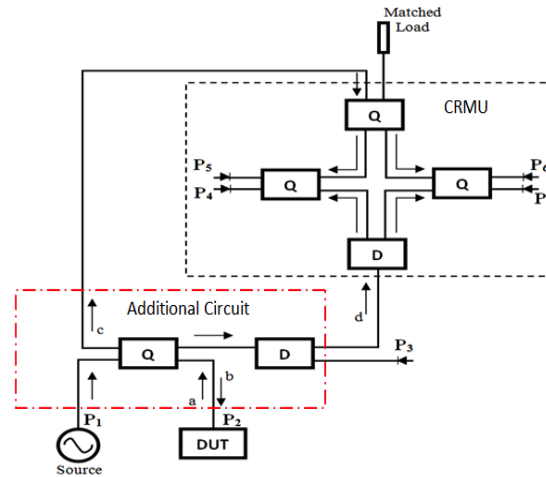

Figure 1. The configuration of the proposed wideband multi-port reflectometer

This multi-port reflectometer is assumed to have power dividers and couplers in ideal operation and identical power detectors that function in the square-law region. Therefore, the reflection coefficient,  $\Gamma$  of the DUT for the proposed configuration in Figure 1 can be obtained from the measured power,  $P_i$  at five output ports is equal to  $|V_i|^2$ , which notation  $i$  indicates the port number ( $i = 3, 4, 5, 6$  and  $7$ ) using similar mathematical derivations in [1-2]. The corresponding representation of  $\Gamma$  also can be determined from the known scattering parameters of the wideband multi-port reflectometer as in following Equation (1):

$$\Gamma = \frac{(|S_{41}|^2 - |S_{51}|^2) + j(|S_{61}|^2 - |S_{71}|^2)}{|S_{31}|^2} \quad (1)$$

Corresponding to the Port 4 to 7, the output voltage,  $V_i$  can be written in the form of reflection coefficient ( $\Gamma$ ), incident signal ( $b$ ) and centre of the power circle or known as  $q$ -points as expressed in (2) [2]:

$$V_4 = -\frac{b}{2\sqrt{2}}(\Gamma - q_4), \quad V_5 = \frac{jb}{2\sqrt{2}}(\Gamma - q_5), \quad V_6 = \frac{b}{2\sqrt{2}}(\Gamma - q_6), \quad V_7 = -\frac{jb}{2\sqrt{2}}(\Gamma - q_7) \quad (2)$$

where,  $|\Gamma - q_i|$  presents the radius of power circle. Alternatively,  $V_i$  can be computed from the input voltage ( $V_0$ ), transmission coefficient ( $S_{ij}$ ) and reflection coefficient ( $\Gamma$ ) as expressed in (3) [2]. Notation  $j$  is referring to 1 and 2.

$$V_i = V_0(S_{i1} + S_{21}S_{i2}\Gamma) \quad (3)$$

From Equation (3), the reflection coefficient ( $\Gamma$ ) can be rewritten to expression (4) [2]:

$$\Gamma = \frac{V_i}{V_0 S_{21} S_{i2}} - \frac{S_{i1}}{S_{21} S_{i2}} \quad (4)$$

Meanwhile, the following Equation (5) is used to determine the value at the centre of power circle ( $q$ -points) as presented in [2] and [8]:

$$q_i = -\frac{S_{i1}}{S_{i2}S_{21} - S_{i1}S_{22}} \quad (5)$$

As ideal components are assumed to be used in the construction of the multi-port reflectometer, the parameter  $S_{22}$  in equation (5) is very close to zero. Hence, Equation (5) can be simplified to (6):

$$q_i = -\frac{S_{i1}}{S_{i2}S_{21}} \quad (6)$$

Referring to (6), the chosen configuration of the multi-port reflectometer in the ideal case offers the location of  $q_i$  at 1,  $j1$ ,  $-1$  and  $-j1$ . This represents the separation of  $90^\circ$  between  $q$ -points. Whereas, the phase characteristics and operation at the centre of power circles ( $q_i$ ), where  $i = 5, 6, 7$  can be referred against  $q_4$  as expressed in following Equation (7):

$$\text{phase}(q_{\Delta i}) = \text{phase}(q_i) - \text{phase}(q_4) \quad (7)$$

By adopting equation (4) and (6) to  $|\Gamma - q_i|$ , the radius of power circle is formulated as in (8):

$$\text{radius} = |\Gamma - q_i| = \left| \frac{V_i}{V_0 S_{21} S_{i2}} \right| \quad (8)$$

By considering the information of power circle centres ( $q_i$ ) and radius given by Equation (8), four circles can be defined. In a graphical form, the reflection coefficient,  $\Gamma$  of any DUT can be presented by the intersection of these power circles [2, 8]. More output ports can significantly improve the multi-port reflectometer performance and make it less sensitive to power measurement errors by having more power circles [2, 8]. However, the accuracy improvement does not ordinarily warrant additional complexity.

### 3. Measurement

In this paper, the proposed wideband multi-port reflectometer configuration is formed by using the commercially available components, which are Krytar  $90^\circ$  hybrid coupler and Aeroflex two-way in-phase power divider as illustrated in Figure 2 (a) and (b). While, the shown cable in Figure 2 (c) is used to connect the couplers and power dividers. The investigation of the characterization and operation of wideband multi-port reflectometer is conducted in the laboratory. Figure 3 represents the photograph of the proposed multi-port reflectometer setup that is performed in the laboratory.

Initially, the characterization of the proposed wideband multi-port reflectometer is investigated in order to obtain the good performance over the wideband frequency range between 1 and 6 GHz. The characterization of the proposed wideband multi-port reflectometer is presented through the centre of power circle ( $q$ -points). Then, the operation of the proposed wideband multi-port reflectometer is evaluated through three unknown DUTs in terms of their magnitude of reflection coefficients. Three DUTs of microstrip-line with slotted-ground are used throughout the investigation, which named as unknown load #1, unknown load #2 and unknown load #3. The photographs of these three unknown loads are shown in Figure 4 and 5 for top and bottom view, respectively. These three unknown DUTs are connected to Port 2 of the wideband multi-port reflectometer. Afterward, their reflection coefficients are computed using the measured S-parameter at output ports with using the equation (1). The obtained performances of the characterization and operation for the proposed wideband multi-port reflectometer are discussed in the next following section.

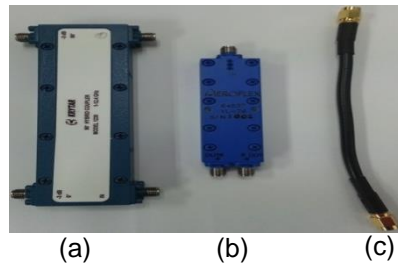

Figure 2. The components used to form the proposed wideband multi-port reflectometer: (a) Krytar 90° hybrid coupler (b) Aeroflex two-way in-phase power divider and (c) cable.

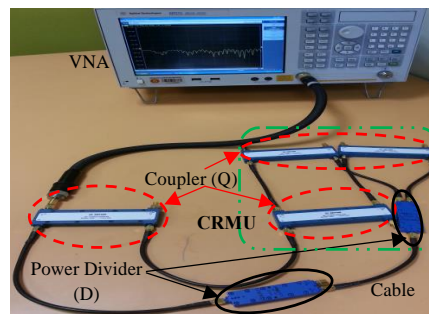

Figure 3. The measurement setup of the proposed multi-port reflectometer

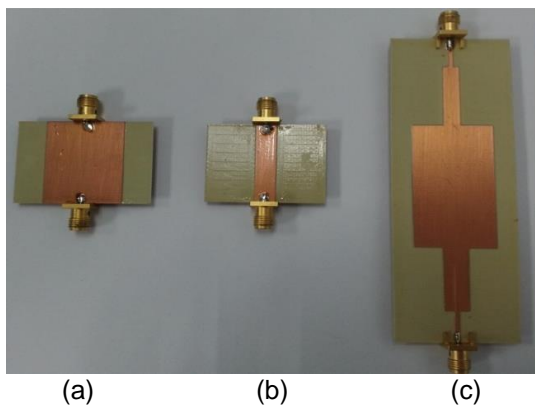

Figure 4. Photograph of the top view of three DUTs: (a) unknown load #1 (b) unknown load #2 and (c) unknown load #3

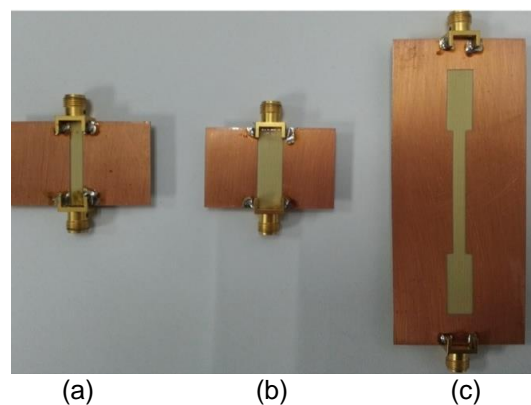

Figure 5. Photograph of the bottom view of three DUTs: (a) unknown load #1 (b) unknown load #2 and (c) unknown load #3

#### 4. The Characterization and Operation of Wideband Multi-Port Reflectometer

The transmission coefficients of the proposed reflectometer, which fixed as in Figure 3 are approximately around  $-12 \text{ dB} \pm 3 \text{ dB}$ . While, the return losses of the wideband multi-port reflectometer are observed at Port 1 and Port 2. Referring to the concerned operating frequency band, which is from 1 to 6 GHz, the Port 1's return loss is better than 20 dB. Whilst, the return loss at Port 2 is finer than at Port 1 for the similar operating frequency band, which is greater than 22 dB. Meanwhile, the referenced phase values of the transmission coefficients against the phase of  $S_{41}$  and  $S_{42}$  stay roughly around  $0^\circ$ ,  $90^\circ$  and  $-90^\circ$  over the designated frequency band. By having this information of transmission coefficients and phases, the characteristics of the centre of the power circles ( $q$ -points) are identified in purpose to have a good wideband performance of the multi-port reflectometer. To determine the  $q$ -points ( $q_i$ ), where  $i = 4, 5, 6$

and 7; the information on the transmission coefficients referenced to Port 1 ( $S_{i1}$ ), and Port 2 ( $S_{i2}$ ) are applied to equation (6). The results of the  $q$ -points are presented in constellation form or also known as the polar plane in Figure 6. The point  $q_4$  is assumed as the reference point, and it is located at a fix ideal position of 1, and the other remaining points are relative to the point  $q_4$ . The remaining  $q$ -points are located  $90^\circ$  of the angular separations. Referring to Figure 6, the magnitude of the  $q$ -points are approximately around  $1 \pm 0.5$  over the frequency band between 1 and 6 GHz. Followed by the phase characteristics of  $q_4$  to  $q_7$ , which are approximately around  $0^\circ$ ,  $-180^\circ$ ,  $-90^\circ$  and  $90^\circ$ , respectively.

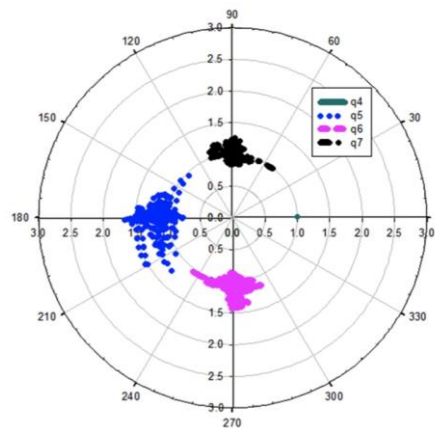

Figure 6. Polar plot (constellation) of the centre of power circle ( $q$ -point) of the proposed wideband multi-port reflectometer

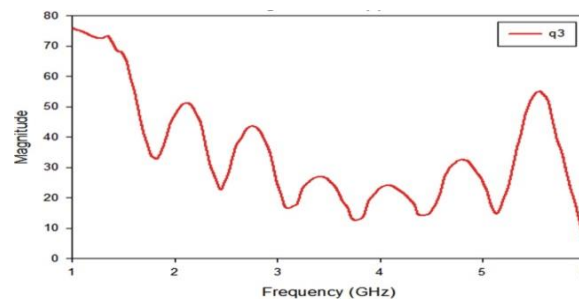

Figure 7. Magnitude of  $q_3$  of the proposed wideband multi-port reflectometer.

In the investigation of the  $q$ -points, there is one remaining criterion that needs to be verified, which is the magnitude of the  $q_3$ . This criterion concern the condition of  $|q_3| > 1$  and  $|q_i| < |q_3|$ , where  $i = 4, 5, 6$  and  $7$ . The obtained measured result from the magnitude of the  $q_3$  is plotted in Figure 7. As seen in Figure 7, the values of the  $|q_3|$  are greater than 4 over the frequency band of 1 to 6 GHz. Therefore, the measurement results of the  $|q_3|$  are meeting the requirement of the stated conditions, which are  $|q_3| > 1$  and  $|q_i| < |q_3|$ . The next concern is to evaluate the multi-port reflectometer operation in the reflection coefficient measurement of DUT. The results of the magnitudes of the complex reflection coefficients for unknown load #1, unknown load #2 and unknown load #3, where these loads are measured using VNA and the proposed wideband multi-port reflectometer (R) are shown in Figure 8.

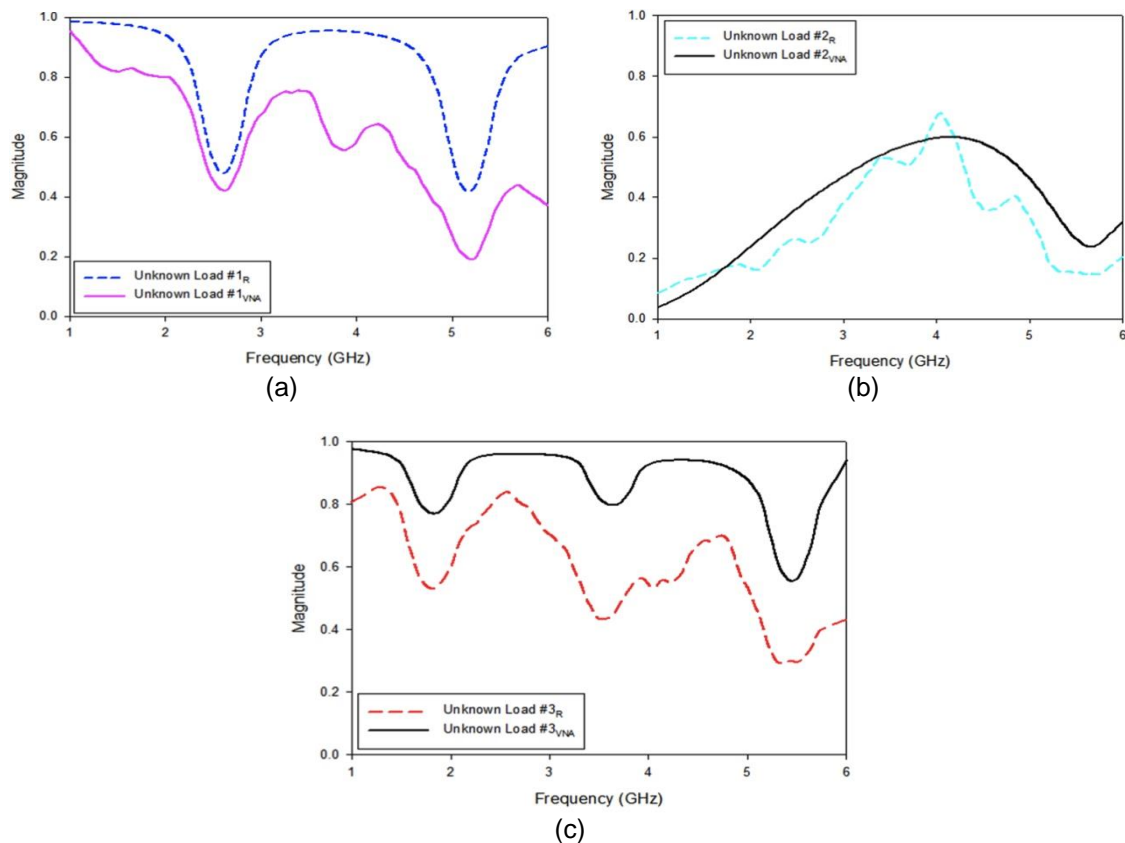

Figure 8. The measured reflection coefficients ( $\Gamma$ ) for (a) unknown load #1, (b) unknown load #2 and (c) unknown load #3 using the proposed wideband multi-port reflectometer (R) and VNA

As seen in Figure 8(a), for unknown load #1, the magnitude of the complex reflection coefficients ( $\Gamma$ ) from VNA is approximately at 1 with two slopes in regard to lowest measured result around  $0.5 \pm 0.05$  at 2.5 and 5.2 GHz. While for the measured result obtained by using the proposed wideband multi-port reflectometer,  $|\Gamma|$  has similar pattern with lower magnitude. The two slope patterns are noticed at similar frequency points.

Then, when DUT is in the form of unknown load #2, as point out in Figure 8 (b); the obtained  $|\Gamma|$  by using VNA is initially at 0 and it increases up to 0.55 at 4 GHz. Henceforth,  $|\Gamma|$  is decreased gradually with lowest value of 0.22 at 5.7 GHz. Then, it increases to 0.3 at 6 GHz. Whilst, the measured  $|\Gamma|$  of unknown load #2 from the proposed wideband multi-port reflectometer shows non-linear progression and reduction across the designated frequency range but following similar pattern with slightly different magnitude. Meanwhile, for the case of unknown load #3; the measured  $|\Gamma|$  from VNA demonstrates three lumps with highest values close to 0.9. Three slopes can be noticed at 1.8, 3.8 and 5.5 GHz with the measured  $|\Gamma|$  of 0.8, 0.8 and 0.5, accordingly. While,  $|\Gamma|$  that measured by the proposed wideband multi-port reflectometer shows identical trend with lower magnitude.

Based on the observation from Figure 8, the patterns of the reflection coefficients of the measured DUTs from VNA and the proposed wideband multi-port reflectometer (R) are almost similar between 1 and 6 GHz. However, the results that have been demonstrated by the proposed reflectometer are slightly deviated from the VNA because it is not operating in error-free state condition. In order to have accurate results, suitable error correction procedure or known as calibration should be applied in future investigations to remove any imperfect characteristics (errors). There are various methods for correcting the imperfect operation of such device like six-port to four-port reduction [9-10] and using the different number of standards from five to seven [11-12].

## 5. Conclusion

The characterization and operation of the wideband multi-port reflectometer have been observed through the centre of power circle ( $q$ -points) and the magnitude of the complex reflection coefficient by implementing commercially available hardware measurement in the laboratory, which are Krytar 90° hybrid coupler and Aeroflex two-way in-phase power divider over the wideband frequency band of 1 to 6 GHz. The analysis on the characteristics and operation of the wideband multi-port reflectometer represents the performance of the proposed device. Based on the measurement results that have been obtained, it can be stated that this multi-port reflectometer has offered a good wideband performance compared to narrower performance shown by [5] and [10]. Even though [1-2], [4, 8] exhibited very wide performance, however [2] and [8] only considered reflectometer characteristics, while [1] and [4] demonstrated simulated operation without experimental results. Nevertheless, the performance of the proposed wideband multi-port reflectometer still can be improved in future investigations by applying a suitable error correction procedure. This is due to the presented wideband multi-port reflectometer is not operating in error-free state condition. By applying the suitable error correction procedure; the imperfect characterization of the wideband multi-port reflectometer will be removed, and an accurate reflection coefficient measurement can be performed.

## References

- [1] Bialkowski ME, Seman N, Leong MS, Yeo SP. *Fully integrated microwave reflectometer in multi-layer microstrip-slot technology for ultra wideband applications*. 2008 17th International Conference on Microwaves, Radar and Wireless Communications, MIKON. 2008.
- [2] Seman N, Bialkowski ME. Design of a UWB Microwave reflectometer with the use of a microstrip-slot technique. *Microwave Opt Technol Lett*. 2009; 51(9): 2169-2175.
- [3] Hoer CA. A network analyzer incorporating two six-port reflectometers. *IEEE Trans Microwave Theory Tech*. 1977; 25(12): 1070-1074.
- [4] Seman N, Bialkowski ME. *Design of a UWB 6-port reflectometer formed by microstrip-slot couplers for use in a microwave breast cancer detection system*. IEEE Antennas and Propagation Society, AP-S International Symposium (Digest). 2007.
- [5] Yob RC, Seman N. *Wideband multi-port reflectometer in microstrip planar technology for microwave imaging application*. 2012 IEEE Asia-Pacific Conference on Applied Electromagnetics, APACE 2012 - Proceedings. 2012.
- [6] Bialkowski ME, Abbosh AM, Swayn J. *Design of a compact microwave six-port vector voltmeter for UWB applications*. IEEE MTT-S International Microwave Symposium Digest. 2007.
- [7] Bialkowski ME, Abbosh AM, Seman N. Compact microwave six-port vector voltmeters for ultra-wideband applications. *IEEE Trans Microwave Theory Tech*. 2007; 55(10): 2216-2223.
- [8] Engen GF. The Six-Port Reflectometer: An Alternative Network Analyzer. *IEEE Trans Microwave Theory Tech*. 1977; 25(12): 1075-1080.
- [9] Potter CM. *Robust six- to four-port reduction algorithm*. IEEE MTT-S International Microwave Symposium Digest. 1993.
- [10] Wright AS, Judah SK. Robust six-to-four port reduction technique for the calibration of six-port microwave network analysers. 1990.
- [11] Hunter JD, Somlo PI. An Explicit Six-Port Calibration Method using Five Standards. *IEEE Trans Microwave Theory Tech*. 1985; 33(1): 69-72.
- [12] Somlo PI, Hunter JD. A Six-Port Reflectometer and its Complete Characterization by Convenient Calibration Procedures. *IEEE Trans Microwave Theory Tech*. 1982; 30(2): 186-192.