

Generator Contribution Based Congestion Management using Multiobjective Genetic Algorithm

Sawan Sen^{*1}, Priyanka Roy², Abhijit Chakrabarti³, Samarjit Sengupta⁴

^{1,2}EE Department, Techno India, Kolkata, India

³EE Department, Bengal Engineering and Science University, Shibpur, India

⁴Department of Applied Physics, Kolkata, West Bengal, India

e-mail: sen_sawan@rediffmail.com^{*1}, roy_priyan@rediffmail.com²,
a_chakrabarti55@yahoo.com³, samarsgp@rediffmail.com⁴

Abstrak

Manajemen kongesti adalah salah satu fungsi utama operator sistem pada industri daya terstrukturisasi selama kontigensi tak terduga. Makalah ini mengusulkan sebuah metoda manajemen kongesti menggunakan algoritma genetik multi-objek berbasis kontribusi pembangkit. Pada algoritma ini, rugi-rugi real dan reaktif dioptimasi menggunakan model aliran daya optimal dan kontribusi dari pembangkit yang rugi-ruginya dioptimalkan adalah dikalkulasi. Pada level kedua, jalur yang mengalami kongesti diidentifikasi dengan indeks beban berlebih yang diusulkan selama kontigensi, dan jalur tersebut dilonggarkan dengan kontribusi baru dari pembangkit, yang merupakan keluaran dari algoritma yang dikembangkan. Metoda yang direncanakan menggambarkan informasi terkait manajemen kongesti untuk meminimalkan biaya investasi, tanpa instalasi piranti eksternal dan untuk memaksimalkan kesejahteraan konsumen dengan menghindari pembatasan beban tanpa mengakibatkan profil tegangan dari sistem sedemikian hingga rugi sistem total teroptimasi. Sistem bus IEEE 30 digunakan untuk mendemonstrasikan keefektifan dari metode yang diusulkan.

Kata kunci: algoritma genetik, indeks beban berlebih, jaringan daya teregulasi, kontigensi, manajemen kongesti

Abstract

Congestion management is one of the key functions of system operator in the restructured power industry during unexpected contingency. This paper proposes a method for generator contribution based congestion management using multiobjective genetic algorithm. In the algorithm, both real and reactive losses have been optimised using optimal power flow model and the contributions of the generators with those optimised losses are calculated. On second level, the congested lines are identified by the proposed overloading index (OI) during contingency and those lines are relieved with the new contribution of generators, which is the outcome of the developed algorithm. The planned method depicts the information related to congestion management to minimize the investment cost, without installing any external devices and to maximise the consumer welfare by avoiding any load curtailment without affecting the voltage profile of the system as well as the optimised total system loss. IEEE 30 bus system is used to demonstrate the effectiveness of the method.

Keywords: congestion management, contingency, deregulated power network, genetic algorithm, overloading index

1. Introduction

The basic requirement of power network is to meet the demand even in contingent state of the system. But the transmission loss incurs roughly 3% to 5% of the total power generation, which may be considered as one of the major factors in deregulated power system, i.e. loss allocation may considerably affect the competitive position of the GENCOs in the power network. Nevertheless, it seems that most of the electrical markets hardly ever reflect the transmission loss in their spot pricing due to the complicated aspects of loss allocation [1]. Earlier researchers have discussed different models for loss allocation in classical methods. It can be modeled by incremental transmission loss (ITL) coefficient [2], physical flow-based approach [3]. Bus impedance matrix [4] or basic circuit theories [5] have been used to trace the power flow of the network during cattering the demand. Again efficient computation algorithm [6], load flow method [7], on line optimal power flow (OPF) tools [8] had been also introduced for

loss allocation. In other literature [9] genetic algorithm (GA) technique is also used for loss tracing. Although loss allocation can be ensured but still no bodies can guarantee that unexpected situations such as generator fault, line fault or tripping would not happen. In this unprecedented state, the loss allocation may change and some new technique has to be implemented to maintain system security.

For the development of the proposed technique, contingency like tripping of line has to be considered. In case of any kind of line fault of the power network, the power, which had flowed through the tripped line, should flow through other existing lines to meet consumer's expectation [10]. This causes the possibility of other line becomes overloaded or congested. Thus transmission loss during power transmission and line congestion are the most important issues for deregulated power environment, where spot price is the main consideration for consumer welfare. Hence, a transparent method for congestion relief during contingency and allocating transmission loss between all of the interested parties in an equitable and fair manner is required. There are several researches in exploiting the releasee of line overflow. Congestion of line can be managed by different way e.g. load curtailment, economic load management, VAR support [11].

At this step, an essential and challenging task is to develop a soft computing method, which optimize the total system loss as well as generate power schedule to minimize the investment cost with out installing any external devices and to maximise the consumer welfare by avoiding any load curtailment for congestion management under deregulated environment.

In this paper, the basic concept of GA based loss optimization is laid under the OPF model where loss is function of B-coefficients for active power and C-coefficient for reactive power. With the optimised loss values, the generator contribution also has been found out through this proposed model. In the paper, an overloading index (OI) has also been proposed to find out the congested lines for any type of contingency. The generation schedule, with optimized loss also has been used to relief line overflow without load curtailment even during contingency. Through classical analysis, voltage profile has been checked with proposed generation schedule, which yields satisfactory result. Actually GA analysis helps to find out the most effective generation schedule, which has been used for congestion management along with loss optimisation of the overall system. It also assists to come to a decision that no external compensation, load curtailment is required for congestion management up to a certain limit in a deregulated power environment.

2. Proposed Method

In this paper, the flow of proposed method is divided in two steps. In the first step, generator contribution can be determined based on loss optimization using GA and these re-contributions of generators have been used to relief the congested transmission lines during contingency in the next step.

2.1. Loss Optimization using GA

GA is a global adaptive search technique based on the mechanics of natural genetics [9]. It is applied to optimize existing solutions by using biological evolution based methods. It has many applications in certain types of problems that yield better results than the commonly used methods without any complicated classical calculation. To solve a specific problem with GA, a function known, as objective function needs to be constructed which allows different possible solutions to be evaluated. The algorithm will then take those solutions, which seem to show some activity towards a working solution.

2.1.1. Problem formulation considering OPF

The objective function for conventional cost optimization is as follows

$$\text{Minimize } F = \sum_{n=1}^{NG} C_n \quad \$/\text{hr} \quad (1)$$

$$\text{where, } C_n = A(P_{gi}^0)^2 + BP_{gi}^0 + C \quad (2)$$

But in the proposed method, the objective function considering the total active and reactive loss can be formulated as follows

$$F'(x) = \text{minimize } (P_L) = \sum_{i=1}^n \sum_{j=1}^m P_{Gi} B_{ij} P_{Gj} = B_{00} + \sum_{i=1}^n B_{i0} P_{Gi} + \sum_{i=1}^n \sum_{j=1}^m P_{Gi} B_{ij} P_{Gj} \quad (3)$$

$$F''(x) = \text{minimize } (Q_L) = \sum_{i=1}^n \sum_{j=1}^m Q_{Gi} C_{ij} Q_{Gj} = C_{00} + \sum_{i=1}^n C_{i0} Q_{Gi} + \sum_{i=1}^n \sum_{j=1}^m Q_{Gi} C_{ij} Q_{Gj} \quad (4)$$

P_L and Q_L , the active and reactive loss terms can be expressed using B and C-coefficient [12] as follows:

$$P_L = \sum_{i=1}^n \sum_{j=1}^m P_{Gi} B_{ij} P_{Gj} = B_{00} + \sum_{i=1}^n B_{i0} P_{Gi} + \sum_{i=1}^n \sum_{j=1}^m P_{Gi} B_{ij} P_{Gj} \quad (5)$$

where

$$B_{ij} = \frac{\cos(\theta_i - \theta_j) R_{ij}}{\cos \varphi_i \cos \varphi_j |V_i| |V_j|}, B_{i0} = - \sum_{j=1}^m (B_{ij} + B_{ji}) P_{Dj} \text{ and } B_{00} = \sum_{i=1}^n \sum_{j=1}^m P_{Di} B_{ij} P_{Dj} \quad (6)$$

$$Q_L = \sum_{i=1}^n \sum_{j=1}^m Q_{Gi} C_{ij} Q_{Gj} = C_{00} + \sum_{i=1}^n C_{i0} Q_{Gi} + \sum_{i=1}^n \sum_{j=1}^m Q_{Gi} C_{ij} Q_{Gj} \quad (7)$$

$$C_{ij} = \frac{\cos(\theta_i - \theta_j) X_{ij}}{\cos \varphi_i \cos \varphi_j |V_i| |V_j|}, C_{i0} = - \sum_{j=1}^m (C_{ij} + C_{ji}) Q_{Dj} \text{ and } C_{00} = \sum_{i=1}^n \sum_{j=1}^m Q_{Di} C_{ij} Q_{Dj} \quad (8)$$

where $\theta_j = \delta_j - \varphi_j$ and $\theta_i = \delta_i - \varphi_i$

The inequality or generator output constraints

$$P_{gi}^{\min} \leq P_{gi}^0 \leq P_{gi}^{\max} \quad (9)$$

$$Q_{gi}^{\min} \leq Q_{gi}^0 \leq Q_{gi}^{\max} \quad (10)$$

$$\Delta P_{gi}^{\min} \leq \Delta P_{gi}^j \leq \Delta P_{gi}^{\max} \quad (11)$$

$$\Delta Q_{gi}^{\min} \leq \Delta Q_{gi}^j \leq \Delta Q_{gi}^{\max} \quad (12)$$

Voltage constraint:

$$|V_i^{\min}| \leq |V_i^j| \leq |V_i^{\max}| \quad (13)$$

2.1.2. Problem Encoding

Each control variable is called a gene, while all control variables integrated into one vector is called a chromosome. The GA always deals with a set of chromosomes called a population. Transforming chromosomes from a population, a new population is obtained, i.e., next generation is formed. It needs three genetic operators: selection, crossover, and mutation for this purpose.

2.1.3. Initialization

Usually, at the beginning of the GA optimization process, each variable gets a random value from its predefined domain. The generator power outputs have well-defined lower and upper limits, and the initialization procedure commences with these limits given by

$$P_{G_i}^{\min} \leq P_{G_i} \leq P_{G_i}^{\max} \text{ and } Q_{G_i}^{\min} \leq Q_{G_i} \leq Q_{G_i}^{\max} \quad (14)$$

2.1.4. Constraint functions and parent selection

Implementation of a problem in a genetic algorithm is realized within the constraint function. The proposed approach uses the conventional power balance equation as its constraint which can be written as

$$\varepsilon_1 = \sum_{i=1}^n P_{G_i} - P_D - P_L \text{ and } \varepsilon_2 = \sum_{i=1}^n Q_{G_i} - Q_D - Q_L \quad (15)$$

The convergence is obtained when ε_1 for active loss and ε_2 for reactive loss less than a tolerance. Improvement of the average fitness of the population is achieved through selection of individuals as parents from the completed population. The selection is performed in such a way, that chromosomes having higher fitness are more likely to be selected as parents.

2.1.5. Crossover and Mutation

After the selection, GA applies a random generation to cut the strings at any position (the crossover point) and exchanges the substrings between the two chromosomes. Once the crossover is performed, the new chromosomes are added to the new population set. Mutation being another parameter, it involves randomly selecting genes within the chromosomes and assigning them random values within the corresponding predefined interval. The probability of mutation is normally kept very low, as high mutation rates could degrade the evolving process into a random search process.

2.2. Congestion Management with Re- Contribution of Generators

With the re-contribution of generators using equation (3) and (4), congested lines can be relieved during contingency. To find the contingent lines during contingency, an Overloading Index can be defined as change in power flow through a transmission line during contingency of other lines. Mathematically it can be expressed as follows

$$\mu_{mn} = \frac{P_{mn} - \overline{P_{mn}}}{\overline{P_{mn}}} \quad (16)$$

where, P_{mn} and $\overline{P_{mn}}$ are the active power flow through the line m-n after contingency and before contingency respectively. Higher value of this index indicates the more congested line in the power network.

3. Results and Discussion

The feasibility and effectiveness of the proposed method has been demonstrated in the IEEE 30 bus test system as sketched in Figure 1. The test system and production units' properties are given in Tables 1 and 2. For the entire simulation, logic program in GA has been employed to formulate ac power flow model. The standard parameters settings for all the simulations of the adopted GA have been depicted in Table 3.

Through proposed optimization method, GA, the optimized values of scheduled generation for all GENCOs has been determined considering all equality and inequality constraints of optimal power flow as mentioned in (5) to (13) and by taking both active and reactive losses as objective functions. Table 4 illustrates a comparison of the solutions obtained by conventional cost optimization method whose fitness function has been described in (1) and

proposed multiobjective optimization method maintaining the real and reactive loss ((3) and (4)) for a fixed active demand of 283.6 MW and reactive demand of 126.2 MVAR.

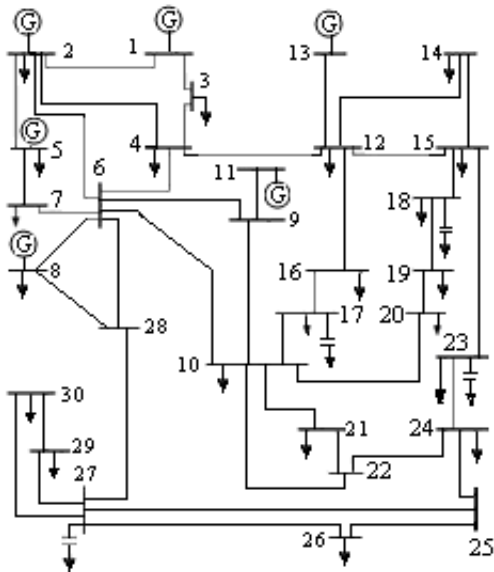

Figure 1. Single line diagram (SLD) of IEEE 30 bus test system

Table 1. Test system properties

Name of parameters	Value
Number of buses	30
Number of generator units	6
Number of branches	43
Number of tie lines	6
Total power demand in MW	283.6

Table 2. Production units' properties

Generator no	P_{max} MW	P_{min} MW	Q_{max} MVAR	Q_{min} MVAR
1	150	50	-2	-5
2	70	50	-0.3	-0.9
3	40	10	30	10
4	50	10	30	10
5	30	10	30	10
6	30	10	40	10

Table 3. Parameter setting of GA based optimization

Name of the parameters	Value
Population size	20
Selection	stochastic uniform
Mutation	adaptive feasible
Crossover	scattered

Table 4. Comparison of generators contributions obtained from conventional cost optimization method (method 1) and proposed multiobjective optimization method (method 2)

Contribution of Generators		Method 1	Method 2
GENCO 1	P_G (p. u.)	1.384	1.235
	Q_G (p. u.)	-0.185	-0.02
GENCO 2	P_G (p. u.)	0.575	0.682
	Q_G (p. u.)	-0.0056	-0.0065
GENCO 3	P_G (p. u.)	0.245	0.339
	Q_G (p. u.)	0.212	0.204
GENCO 4	P_G (p. u.)	0.35	0.334
	Q_G (p. u.)	0.267	0.254
GENCO 5	P_G (p. u.)	0.179	0.105
	Q_G (p. u.)	0.241	0.247
GENCO 6	P_G (p. u.)	0.169	0.207
	Q_G (p. u.)	0.317	0.318
system loss	P_L (p.u.)	0.074	0.067

The changes in real and reactive power contribution for all GENCOs (Figure 2) are within their specified limit as described in (11) to (12). When a line is tripped by a sudden fault, there is a possibility of another line overflow because the power, which had flowed through the tripped line, should flow elsewhere. In these circumstances, a remedial action has to be taken to maintain the system security.

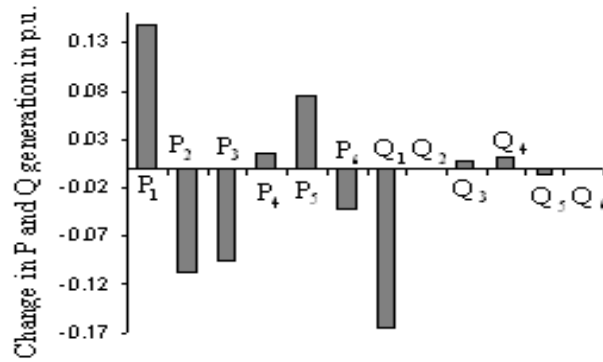

Figure 2. Change in Real and Peactive Power in p.u. for Multiobjective optimization method

The severity of the line fault depends on the amount of power, which had flowed through the tripped line. In this test, five different lines have been tripped that were chosen according to the amount of line flow considered. Table 5 shows the simulation results. For a particular line fault, five most congested lines have been found with the help of the proposed overloading index. With the calculated contribution of GENCOs (Table 4) using proposed optimization; congested lines can be relieved from overloading (Table 5). A remarkable reduction in line congestion has been observed with proposed generation as compared with the generation obtained from conventional cost optimization technique. This reduction of overloading may reduce the cost of congestion which is an integral part of locational marginal price (LMP) [13] in deregulated environment of power system.

Table 5. Congestion management with new schedule of generators contribution

Line fault	Five most congested line	Power flow in p.u.					
		Before Fault (A)	After fault with generation using Method 1 (B)	After fault with generation using Method 2 (C)	% Overload $\left(\frac{B-A}{A}\right)*100$	% Overload with proposed generation $\left(\frac{C-A}{A}\right)*100$	
Case 1	2-4	2-6	0.3802	0.5277	0.4099	38.79	7.80
		3-4	0.4481	0.5552	0.4563	23.91	1.82
		1-3	0.4816	0.5937	0.5039	23.27	4.63
		2-5	0.5802	0.6379	0.5946	9.94	2.48
		10-17	0.6627	0.7176	0.6794	8.28	2.51
Case 2	2-5	2-6	0.3803	0.6666	0.4036	75.30	6.12
		2-4	0.2911	0.5043	0.3186	73.22	9.44
		12-16	0.0594	0.0837	0.0604	40.90	1.68
		24-25	0.0280	0.0316	0.0290	12.91	3.57
Case 3	6-7	4-12	0.2532	0.2767	0.2657	9.292	4.93
		8-6	0.0155	0.0255	0.0157	63.97	1.29
		6-9	0.2076	0.2489	0.2153	19.88	3.70
		9-10	0.1734	0.1973	0.1872	13.74	7.95
Case 4	12-15	6-10	0.1096	0.1214	0.1132	10.70	3.28
		1-2	0.9073	1.0009	0.9145	10.31	0.79
		14-15	0.0535	0.1032	0.0557	92.98	4.11
		12-16	0.0594	0.1000	0.0692	68.19	16.4
Case 5	4-12	22-24	0.0943	0.1237	0.1074	31.16	13.8
		4-6	0.4027	0.4416	0.4116	9.66	2.21
		1-2	0.9073	0.9141	0.9136	0.73	0.69
		6-10	0.1091	0.1689	0.1126	67.10	3.20
		4-6	0.4027	0.6208	0.4100	54.17	1.81
		12-13	0.1091	0.1689	0.1126	14.19	3.20
		2-6	0.3802	0.4201	0.3993	10.47	5.02
		2-5	0.5802	0.5938	0.5874	2.34	1.24

The other important aspect of this proposed method is the reduction of the system operating losses during contingency. Table 6 compares the losses with original contribution

(method 1) and re-contribution of GENCOs (method 2) during contingencies. As shown, the system operating losses have decreased by a considerable amount with re-contribution schedule of GENCOs. Hence, it can be stated that along with the reduction of congestion cost this proposed method can lower system operating losses and thereby the spot price of energy in deregulated environment.

The above advantages of this re-contribution schedule remains less consequent unless it has least effect on the operating conditions of the system. The voltage profiles shown in the Figures 3 to 5 for the test cases, strengthens the competency of the re-contribution schedule with respect to the normal generation schedule. During contingency the voltage profile remains least affected with the imposed schedule. It implies that without affecting the voltage, this new schedule can offer significant benefits like minimization of system losses and locational marginal prices (LMP) in terms of congestion management during contingency and in normal condition of the system. The other important advantage of calculated re-contribution schedule that has been prepared by GA by optimizing the active and reactive losses in deregulated electricity market is that it does not threaten the economic dispatch.

Table 6. Comparison of real losses with original contribution and re-contribution schedule of GENCOs during contingency

Cases	P_L in p.u. with		% reduction in active loss with Re-contribution of GENCOs
	Original contribution of GENCOs	Re-contribution of GENCOs	
Case 1	0.0798	0.0733	8.14
Case 2	0.1427	0.1236	13.38
Case 3	0.0891	0.0775	13.01
Case 4	0.0809	0.0742	8.28
Case 5	0.0813	0.0719	11.48

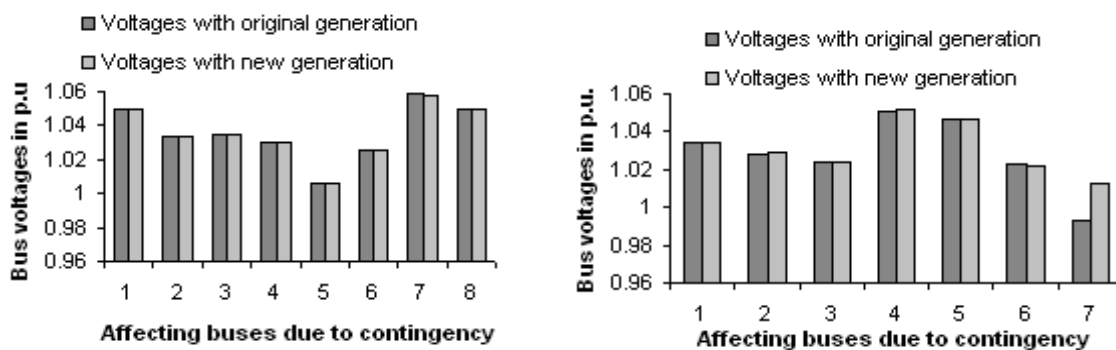

Figure 3. Comparison of voltage during contingency with original and new generation for Case 1 and 2

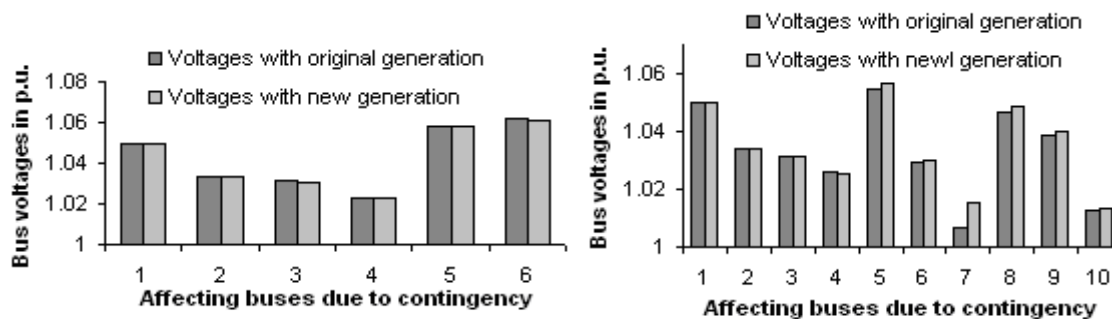

Figure 4. Comparison of voltage during contingency with original and new generation for Case 3 and 4

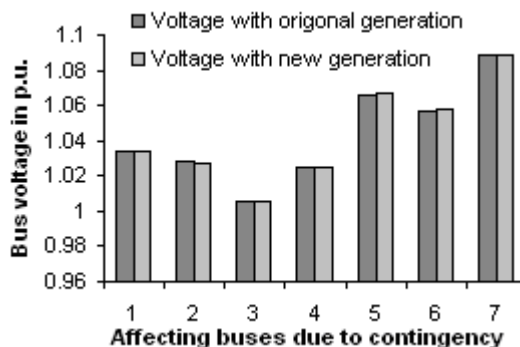

Figure 5. Comparison of voltage during contingency with original and new generation for Case 5

4. Conclusion

This paper proposes a new method, which not only optimizes real and reactive power loss using GA, but also reduces congestion of transmission lines during contingency by using new schedule of generators contributions. The overloading index, proposed in this paper can efficiently trace the congested lines in contingency so that a remedial action can be taken to relief the line from congestion. In this paper, the new generation schedule obtained by the proposed loss optimisation GA model has been taken as a corrective measure for congestion management. This loss optimisation based generation schedule has been coupled with load flow to check the voltage profile of the system along with congestion management of the transmission lines during contingency. The test results show that the new schedule of generation is a powerful tool for congestion management scheme over the other schemes such as load curtailment and FACTS device inclusion.

References

- [1] Kyung M, Sang-Hyeon H, Su-Won L, Young-Hyun M. Transmission loss allocation algorithm using path-integral based on transaction strategy. *IEEE Transaction on Power Systems*. 2010; 25(1):195-205.
- [2] Schweppe F, Caramanis R, Tarbor R, Bohn R. Spot pricing of Electricity. Kluwer Academic Publisher. 1988.
- [3] Gross G, Tao S. A physical-flow-based approach to allocating transmission losses in a transaction framework. *IEEE Transaction on Power Systems*. 2000; 15(2): 631–637.
- [4] Chang Y-C, Lu C-N. An electricity tracing method with application to power loss allocation. *International Journal of Electrical Power Energy Systems*. 2001; 23(1): 13-17.
- [5] Abdelkar S. Efficient computation algorithm for calculating load contributions to line flows and losses. *IEE Proc. Of Generation, Transmission and Distribution*. 2006; 153(4): 391-398.
- [6] Abedlkar S. Transmission loss allocation in a deregulated electrical energy market. *Electrical Power System and Research*. 2006; 76(11): 962-967.
- [7] Nepomuceno L, Santos Jr. A. Equivalent optimization model for loss minimization: A suitable analysis approach. *IEEE Transaction on Power Systems*. 1997; 12(4):1403-1412.
- [8] Jen-Hao T. Power flow and loss allocation for deregulated transmission system. *International Journal of Electrical Power and Energy System*. 2005; 27 (1): 327-333.
- [9] Mohd Herwan S, Mohd Wazir M, Omar A. *Transmission loss and load flow allocations via Genetic Algorithm technique*. IEEE Tencon 2009.
- [10] Parnandi S, Schoder K, Feliachi A. *Power Market Analysis tool for Congestion management*. International Conference on Electrical Engineering Design and Technologies. 2007: 4-6.
- [11] Hwa-S, Seung M. *A New Operation Strategy of Series Compensating Device under line flow congestion using linearized line flow sensitivity*. Power Engineering Society Winter Meeting IEEE 2001; 2: 416-420.
- [12] Chakrabarti A, Halder S. *Power System Analysis, Operation and Control*. Fourth Edition PHI Learning Pvt. Ltd, India. 2010.
- [13] Yong F, Zuyi L. *Different Models and Properties on LMP Calculations*. Power Engineering Society General Meeting IEEE. 2006.