

## Investigating Maturity State and Internal Properties of Fruits Using Non-destructive Techniques-a Review

Mohd Fadzli Abd Shaib<sup>1</sup>, Ruzairi Abdul Rahim\*<sup>2</sup>, S. Z. M. Muji<sup>3</sup>, Azian Abd Aziz Ahmad<sup>4</sup>

<sup>1,2,3</sup>InSet (Instrumentation and Sensing Technology), Faculty of Electrical and Electronic Engineering, Universiti Tun Hussein Onn, 86400 Batu Pahat, Johor

<sup>2</sup>Faculty of Electrical Engineering, Universiti Teknologi Malaysia, 81310 Skudai, Johor

<sup>4</sup>Akademi Bahasa, Universiti Teknologi Malaysia, 81310 Skudai, Johor

\*Corresponding author, e-mail: fadzli@uthm.edu.my<sup>1</sup>, ruzairi@fke.utm.my<sup>2</sup>, ruzairi@uthm.edu.my<sup>2</sup>

### Abstract

*The evaluation of internal condition of the fruit via destructive techniques mostly damaged the internal and external fruit structure. However, there are several non-destructive techniques available could be applied in the agricultural industry, specifically for observing internal fruit conditions. Different kinds of internal conditions of fruits are evaluated in terms of their quality and ripeness levels. These non-destructive techniques include fruit evaluation via ultrasonic measurement techniques, light spectroscopy, imaging via Magnetic Resonance Imaging (MRI) and X-Ray, computer vision, electric nose and also vibration. The capabilities and the effectiveness of these techniques towards fruit monitoring are thoroughly discussed. Besides, the drawback of these non-destructive technique has been analysed.*

**Keywords:** non-destructive technique, ripeness, fruit monitoring, attenuation

**Copyright © 2017 Universitas Ahmad Dahlan. All rights reserved.**

### 1. Introduction

It is the norm for the quality of a fruit to be determined by human subjective judgement, involving the use of the five senses, namely, sight, hearing, taste, smell, and touch. However, this conventional method often provides inaccurate and misleading information regarding the condition of fruits, particularly the fruits' internal conditions. Such a limitation has hindered the manual quality inspection process, as good external physical conditions do not guarantee good quality fruits. Besides, some fruit cultivars do not change in peel colour even when ripe.

Quality of fruits can in fact be better judged based on several other parameters, involving size, shape, colour, Total Soluble Solid (TSS), acidity, pH, physiological weight, juice, pulp and moisture content [1]. For these parameters to generate accurate results, destructive techniques are most commonly applied. Such techniques require the internal sample of the mesocarp (flesh) of the fruit to be extracted and analysed further. However, this may damage the fruits being tested. This paper thus explores the potential of various non-destructive techniques in determining fruit conditions.

### 2. Non-destructive techniques in monitoring fruit conditions

Ultrasonic measurement is one of the alternative techniques that may be used to observe the internal conditions of fruits. In this technique, ultrasonic wave is passed through the skin of the fruit via a transmitter and the attenuated wave generated is detected by a receiver. Generally, the frequency of the ultrasonic device operates from a range of 0.5 to 30 MHz. The ultrasonic measurement system for measuring fruit conditions has been designed as in Figure 1. The ultrasonic measuring system comprises several parts, which are the wave generator (pulser/receiver), ultrasonic transducer pairs (transmitter and receiver), microprocessor (with signal processing software) and display monitor. In this system, the transmitter probe is located on the skin of the fruit sample and the ultrasonic signal pulses through the flesh of the fruit, with the receiver probe located at a determined distance from the transmitter probe along the equator of the fruit.

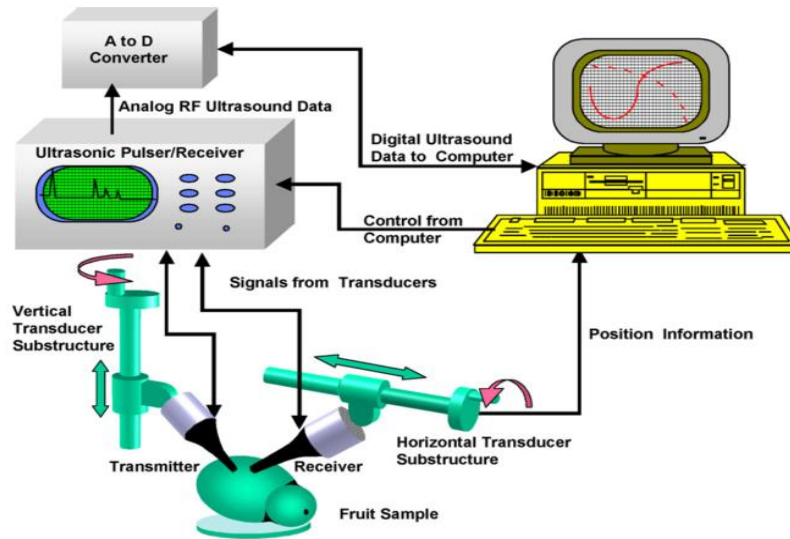

Figure 1. Schematic diagram for continuous-touch ultrasonic system [2]

Another technique used in observing the internal conditions of fruits involves the use of high frequency transducers. 20MHz was used as the central frequency to study two different varieties of oranges. In this technique, both the transducer and samples were immersed in water as in Figure 2 [6]. Ultrasonic waves were released to the peel of the samples from the transducer, with the backscattered signals reflected from the samples received by the transducer. Both different varieties of oranges generated significant differences in terms of attenuation and velocity of signals. This technique is thus suitable to be used in exploring the maturity of oranges through the amount of water content in the outer layer of the orange peel called flavedo.

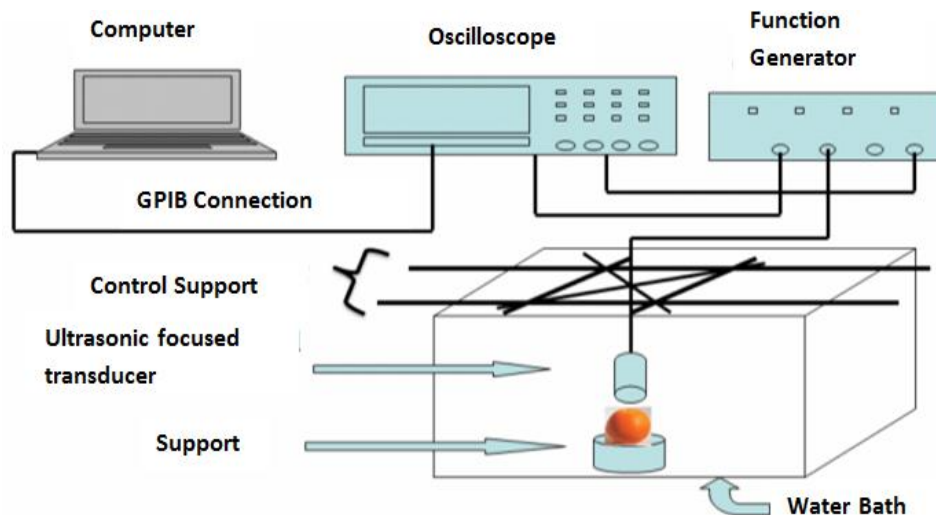

Figure 2. Ultrasonic measuring device for measuring water level in orange peel [6]

The attenuation value of ultrasonic waves received by the receiver depends on the fruit's condition [2]. The researchers found the attenuation of ultrasonic waves in mangos to be higher with increased storage time. As the flesh of mangos softens with the maturity of the fruit with increased storage time, the attenuation will be higher when firmness of the mango decreases. This is in contrast to a study of plum fruit maturity where the attenuation

measurement showed a decrease with increased storage time, due to a decrease in sugar content and firmness with advancing time [3].

The mealiness of apples has also been investigated using the same system, with two different cultivars of apple varieties selected, namely, Jonagold and Cox [4]. Comparison of data obtained from the attenuated ultrasonic signal and confined compression test, indicated a good relationship for fresh and overripe mealiness level of Cox apples. In contrast, data from the Jonagold apples did not show any correlation for different mealiness levels.

The capability of this technique has also been explored in predicting the oil content of fresh palm fruits. The oil content of palm fruits is highly dependent on their species and maturity. The amplitude of the attenuation data was compared to the actual oil content in accordance with the Soxhlet extraction procedure [5]. Based on the comparison between these two data, it can be concluded that the attenuated ultrasonic signal is capable of predicting the oil content of palm fruits without involving any physical penetration of the flesh of the fruit.

In yet another technique, a set of ultrasonic transducers has been designed to generate the desired signals without the need for physical contact between the transducer probe and fruit sample. Instead, the 500 kHz ultrasonic transducer is moved up and down along the line towards the fruit to obtain the first reflection with the highest amplitude of the ultrasonic signal from the sample as in Figure 3 [7]. In testing this technique, the amplitude of the first reflected signal from the apple surface is gradually decreased until about 10 days, which is the time required to test the reduction in apple firmness, density and weight due to biochemical reaction of the apple's rind and pulp as time passes. The main weakness of this method is the intensity of the ultrasonic signal is vulnerable to the changes of the distance between the ultrasonic transducer and the fruit sample in obtaining the maximum reflected signal.

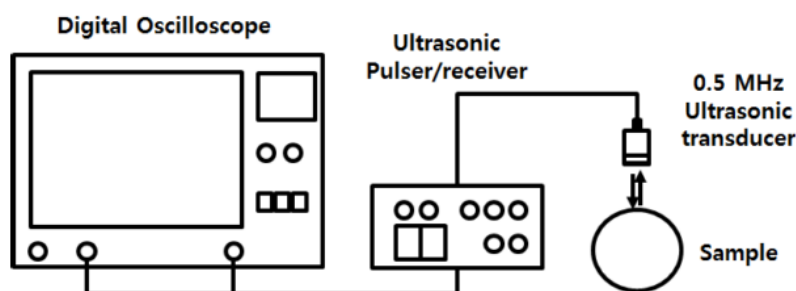

Figure 3. Non-contact ultrasonic measuring system [8]

Visible Light and Near Infrared (NIR) Spectroscopy is the most active technique being explored by researchers in observing fruit quality. Spectroscopy is the scientific technique for measuring light that is emitted, absorbed or scattered by the sample to be studied and identified. Generally, there are two types of spectroscopy which are most commonly used to observe fruit conditions, namely, the interactance and reflectance method as shown in Figure 4 [9]. Interactance measurement involves light absorption of the flesh of the fruit within a maximum depth of 1 cm. This involves fibre optic probe that is pressed against the fruit surface to allow light to penetrate the fruit content. However, the reflectance measurement is a non-contact method which is only suitable for flesh that is just below the skin of the fruit.

Time Resolved Reflectance Spectroscopy (TRS) in 540-900nm spectral range has also been explored in studying the internal conditions of 60 mango fruits. The TRS set up is shown in Figure 5 which consists of a light source from a supercontinuum laser, a filter wheel for spectral selection, with reflected light from the sample detected by the photomultiplier. The spectral range chosen is under a visible light spectrum. Based on the study, carotenoid absorption indicated high variability at the spectral range of 630-690nm, but less variability for chlorophyll absorption peak which was found to be at the 630-690nm spectral range. The readings indicated that most of the mango samples were in a ripened state. Besides, it was also found that the scattering coefficient decreases in correlation with the increasing maturity of the fruits [10].

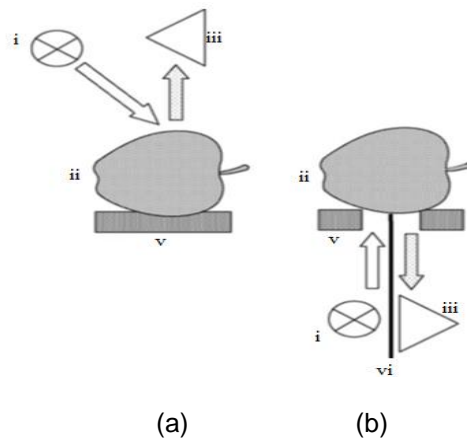

Figure 4. Setup for acquisition of (a) reflectance, (b) interactance spectra, with (i) the light source, (ii) fruit, (iii) monochromator/detector, (iv) light barrier and (v) support [9]

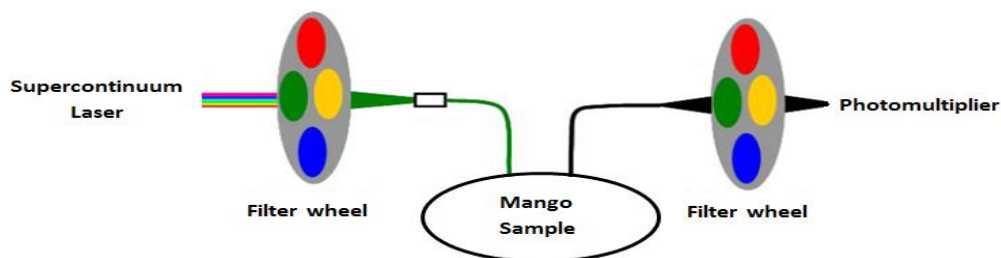

Figure 5. TRS instrumentation setup [10]

The reflectance and fluorescent spectroscopy of visible light and NIR have also been explored for the purpose of investigating fruit maturity like nectarine, mango, papaya and guava. As shown in Figure 6, reflectance spectra are obtained when light from a tungsten lamp is guided through fibre to the fruit sample and the reflected light captured by reflectance probe to the spectrometer. A fluorescent spectra, 385nm fibre coupled with a UV light emitting diode acting as the light source was directed at the fruit sample. The fluorescent radiation was then transmitted to the spectrometer on the same path with the reflectance light. From the testing of each fruit, it was found that the reflectance and fluorescent spectra were sensitive to chlorophyll content. Hence the technique could be an estimator of chlorophyll changes in the fruit ripening process [11]. The reflectance property of NIR spectroscopy was tested with different cultivars of apples, where it was found that the water content of apples decreases with increased shelf-life of the fruit [12].

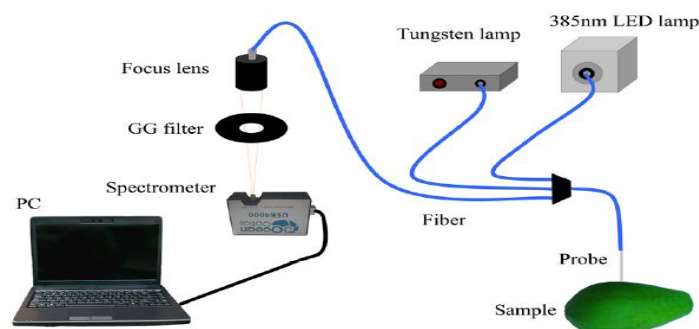

Figure 6. Experimental set up for measurement of reflectance and fluorescent spectra [11]

MRI is also well known as a non-invasive technique which uses magnetic field and radio frequency pulses to image internal organs, soft tissues, bone and other internal body structure. This was the reason why the technique was used to observe the internal structure of fruits for quality monitoring purposes. One aspect of investigation conducted via this technique is for the purpose of seed detection in fruits. In this case, Mandarins were chosen as an object of study. Seed detection in Mandarins has been investigated via MRI since the presence of seeds in the fruit is undesirable based on consumers' demand. Based on this technique, the difference between seedless and seed-containing Mandarins could clearly be distinguished via this technique [13]. The image constructed via MRI has been further investigated based on seed identification precision by radial spiral sequence and gradient echo images with 98.7% and 100% accuracy respectively [14].

The MRI technique has also been applied in studying the maturity levels of tomatoes. The maturity levels of tomatoes were divided into three classes, namely, green, beaker-light red and red. Each class was divided into 5 images where for each image, voxel intensity pattern varies proportional to the maturity level. As tomatoes change to different levels of maturity, the contrast of the image changes, which indicates different water proton properties in tomato pericarp tissues, in line with physiological changes in tomatoes [15]. Capability of the MRI technique has been further explored to observe microporosity in different cultivars of apples, where it was concluded that the microporosity amount depended on cultivars and will vary according to pre-and post- harvest conditions and maturity [16].

Imaging techniques via X-Ray have been widely used for medical and industrial applications especially in medical radiography and airport security. The electromagnetic wavelength of X-Ray is in the range of 0.01nm to 10nm with frequencies ranging from 30 petahertz to 30 exahertz and photon energies from 100eV to 100keV [17]. In recent years, there has been limited research investigating the imaging capabilities of X-Rays in agricultural applications especially for fruit inspection. The concept of X-Ray computed tomography is based on the X-Ray beams that traverse through objects with the attenuated radiation captured by detectors. This attenuated signal is then used to rebuild the image of the slice of an object that is being inspected.

Based on the X-Ray absorption of an object expressed in terms of CT numbers, the stages of mango ripening from the cultivars Chausa was observed. Based on the comparison of CT numbers and the biochemical properties of the fruit, it was found that both CT numbers and the uniformity in grayness decreased as in Figure 7 [1]. Initially, the flesh of the fruit contained more water, but as time (day) increases, water was gradually replaced by air which reduces the CT number and grayness level [18]. Imaging via X-Ray CT has also been found to be capable of differentiating the quality of chestnuts based on their internal condition. Generally, the internal condition is observed based on internal decay of the chestnut which is divided into five severity of internal decay (complete, high, partial, minimum and no decay or healthy chestnut) [19]. In another case, using the same technique for the imaging of kiwifruits, it was found that different kiwifruit cultivars have different porosity and pore sizes, which are smaller than most other fruits.

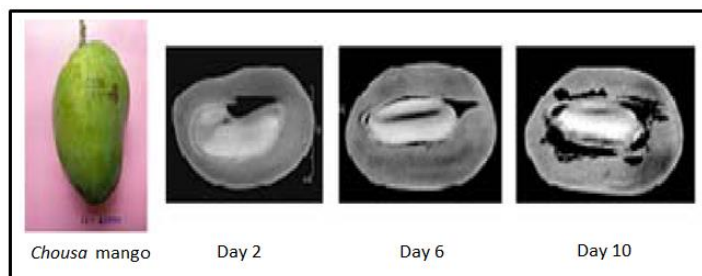

Figure 7. Maturity assessment of Chausa mango using Computed Tomography (CT) [1]

In studies of watercore of apples, the effectiveness of CT and MRI techniques have also been explored and compared. As shown in Figure 8, watercore is a disease where an apple has been exposed to too much sunlight which leads to the fruit to be over mature before its time.

This will cause water-soaked regions in the flesh which normally cannot be observed if the case is minor. However, for severe cases, it can be seen externally by the naked eyes.



Figure 8. Apple with water core disease

Four different apple cultivars were observed via these techniques, with one of the cultivars from the “Rebellón” cultivar variety shown in Figure 9. It was found that the MRI technique offers a higher contrast, hence producing clearer images which can be observed in comparison to the CT technique [20].

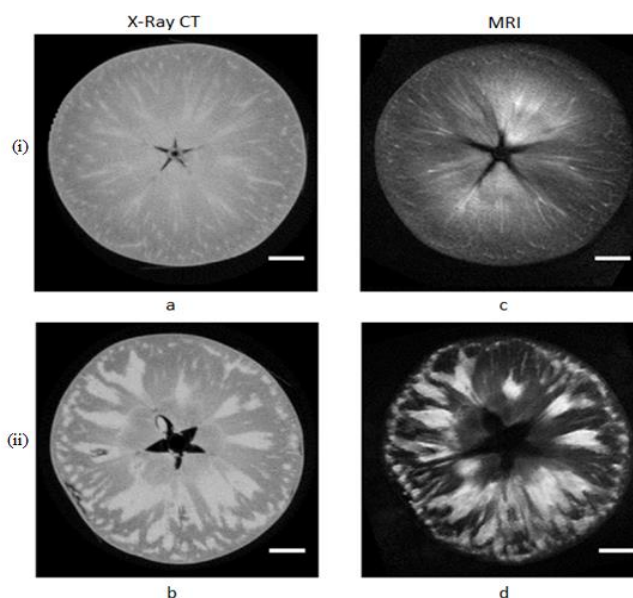

Figure 9. X-Ray CT and MRI images for “Rebellón” apple (i) Normal apple for (a) X-Ray CT and (c) MRI (ii) Watercore disease apple for (b) X-Ray CT and (d) MRI [20]

A computer vision based system can also be considered to be one of the non-destructive techniques which could be explored to determine the internal condition of fruits. This technique involves the study of the internal conditions of fruits based on the external features of the fruit which includes texture, size, shape and peel colour.

In fruit grading system, the capability of the computer vision has been explored. From this technique, a date fruit was grounded and sorted using RGB images in three different levels of quality. As shown in Figure 10, the fruit was placed on a conveyor belt and passed through a computer vision system where the image was captured, and transmitted to an image processor, before being classified, and separated into different bins according to the quality of the date fruit [21]. In another case, the same technique was also used to differentiate between the different levels of maturity of date fruits, namely, immature, changing colour/not mature, mature and ripe [22].

In yet another study that investigated the defect of “Jonagold” apple cultivars, the same technique was used to observe three types of severity levels of the apples, which are bruise, flesh damage and russet. Statistical, textural and geometric features were selected for the analysis of the defective area [23]. Image segmentation via Support Vector Machine (SVM) and Otsu’s thresholding method were shown to be able to sort and grade “Delicious” apple cultivars based on three different skin colours which are orange, stripe or dark red [24]. Classification of percentage defect of an olive fruit was also successfully distinguished based on the infrared vision system using segmentation algorithms, edge detection and pixel value intensity. The category of external defects of olive fruits can be divided into five categories which are healthy olive (100% healthy area), minor defects (>75% healthy area), moderate defects (>50% defective area), several defects (>75% defective area) and defective olives (100% defective area) [25].

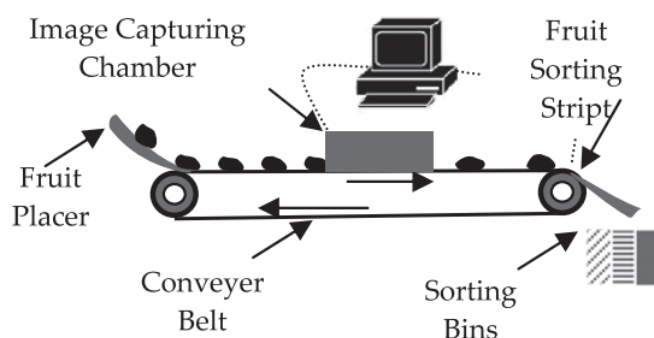

Figure 10. Computer mediated fruit sorting system [21]

In determining and classifying the quality of grapes, the Canny Edge Detection algorithm is applied based on surface texture of the fruits. The grapes’ image was captured at 2-day intervals and grouped in five clusters based on five different days which showed very distinguishable patterns based on different days [26]. For automated strawberry grading system, machine vision technology contributed a significant value in order to increase the commercial value of the strawberry fruit. Based on the three features extracted, namely, shape, size and colour, the automated grading system has been successfully developed with strawberry size detection error to be less than 5%, colour grading accuracy to be at 88.8% and shape classification accuracy to be more than 90% [27]. The same method has also been applied for the purpose of mango fruit grading, where it was found that the technique was able to classify mangos into four different qualities with higher grading accuracy [28].

Computer vision has also been explored for the estimation of mango crop yield. Instead of manually counting the total number of fruits on the mango tree, colour segmentation in RGB and YCbCr colour ranges and texture segmentation are used. However, this technique has been found to be more suitable for less mature fruit in comparison to mature fruit as the former tend to generate more colour variation [29].

Electric nose (e-nose) is another non-destructive method option which can be considered in evaluating fruit quality and its overall condition. This method specifically mimics the biological (human) nose to identify fruit conditions based on its aroma. Generally, an aroma consists of chemical compounds which can be detected by a human nose that consists of 400 receptors [30]. As in Figure 11, these olfactory receptors send signals to the brain through olfactory bulbs and identify the aroma which corresponds with the received volatile chemical composition [31]. As in comparison with the e-nose construction, an array of chemical sensor detects the fruit odour which is then processed by a signal transducer that identify the fruit odour via a pattern recognition engine such as the neural network system.

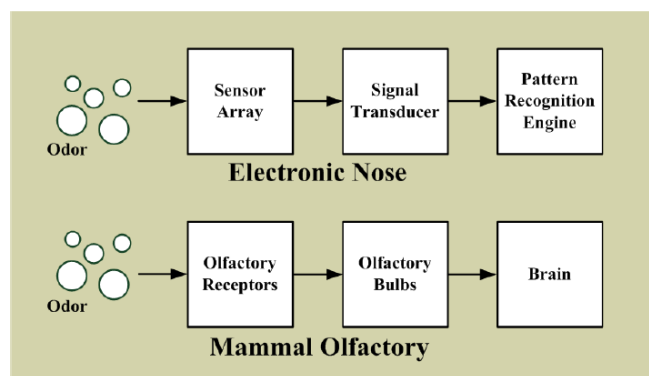

Figure 11. Comparison between electric nose and mammal olfactory [31]

The electric nose based on the Metal Oxide Semiconductor (MOS) system has been explored to classify banana fruits with different level of ripening stages. As in Figure 12, banana fruits for the Cavendish cultivars were placed inside a sample chamber and the aroma collected via a sensor chamber (through valve1, V1), which is then stored and analysed using computers. Based on the Support Vector Machine (SVM) analysis, different maturity level of banana fruits has been successfully determined [32].

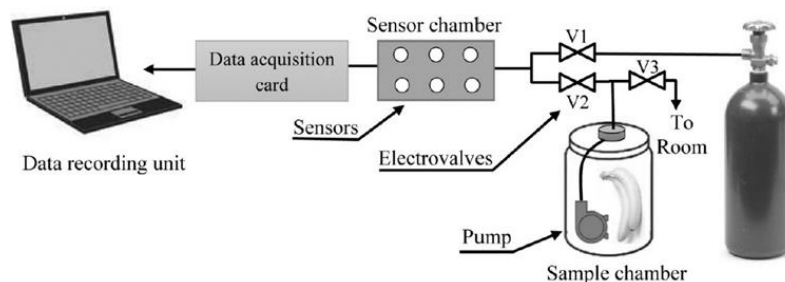

Figure 12. Schematic View for classifying banana fruit ripeness using e-nose [32]

Ripening stage monitoring of mangos after harvesting is also another significant fruit condition that can be observed using the e-nose, which is capable of classifying the mango fruits into three classes, namely, unripe, ripening and ripe. Based on the observation of Volatile Organic Compound (VOCs) of each mango for the Chokanan cultivars, it was found that ripening samples can be segregated based on the total concentration and number of VOCs of the samples as in Figure 13 [33].

Capability of the e-nose has also been explored in differentiating different types of fruits involving guava, orange and banana fruits. Based on VOCs patterns released from these three types of fruits, through analysis using the Principal Component Analysis (PCA), each type of fruit has been successfully identified [34].

The e-nose system could also be applied in determining and discriminating the storage of the fruit shelf-life. Storage shelf-life of mandarin fruits were observed with the fruits kept in three different types of storage; bag and box stored at  $20 \pm 1$  °C and bag stored at  $4 \pm 0.5$  °C. The shelf-life of the mandarin fruits which were kept in a temperature of  $20 \pm 1$  °C and stored using the bag and box, showed similar volatility patterns where the volatility decreases more steeply in comparison with the Mandarins stored in a refrigeration [35]. This indicates, the ripeness of the fruit could be slowed down by slowing down the ripening process after harvesting [36].



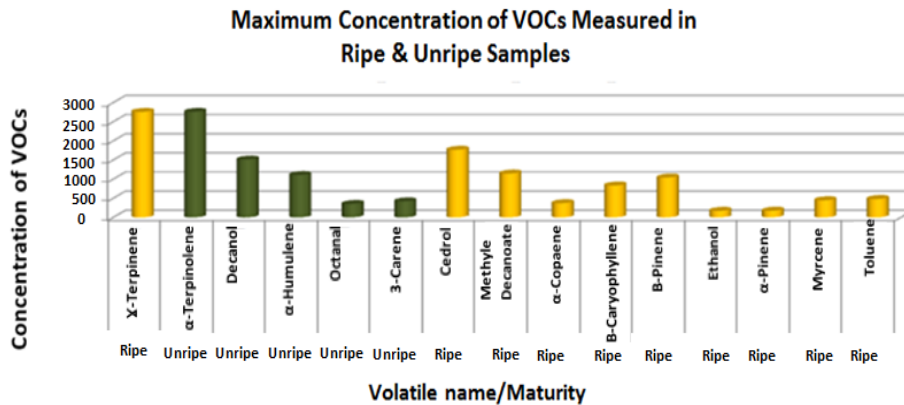

Figure 13. Comparison of common volatiles in ripe and ripening samples [33]

Laser Doppler Vibrometry (LDV) is one of the methods that has been investigated in determining ripeness of fruits. As in Figure 14, a watermelon fruit is placed on a shaker which is then vibrated according to random wave signal frequencies where the vibration spectrum response of the watermelon will be recorded by LDV [37]. Based on different spectrum patterns, the ripeness of the watermelon is then identified.

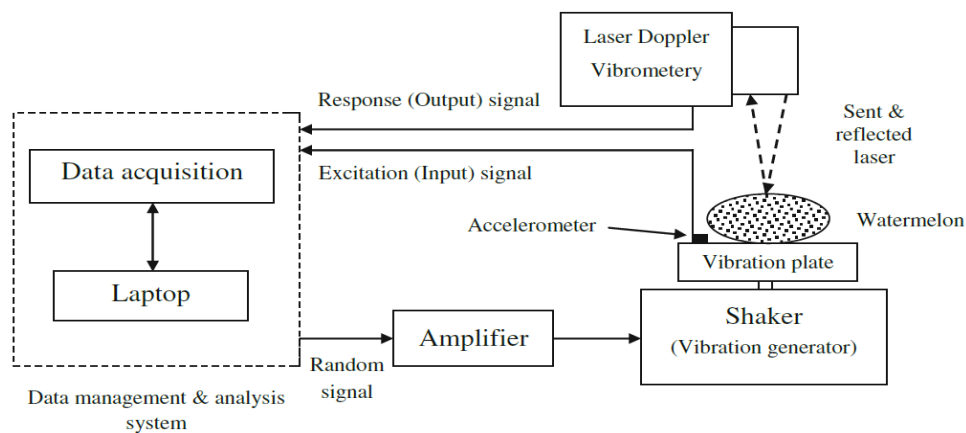

Figure 14. Set up for measuring vibration response by LDV [37]

### 3. Conclusion

Based on different type of technique explored, generally fruit monitoring techniques are divided into two parts which are qualitative and quantitative analysis. The qualitative analysis is where the information obtained from the external appearance of the fruit such as fruit skin, and the aroma released from the fruits whereas the quantitative evaluation is based on the value obtained from signal released inside the fruit and the response received based on the penetrated signal that released from the fruit.

Most fruit evaluation methods are based on the examination of specific spots on the fruits instead of the whole fruit. For example, measurement using the ultrasonic method [2] only evaluates just a few mm under the fruit's surface, which does not represent the condition of the fruit overall. Fruit evaluation via visible light and NIR spectroscopy technique [9] also uses the same idea where the fruit is evaluated just a few cm under the fruit's surface. Besides, these methods require direct contact between the fruit surface and the sensor's probe. Hence, there is a medium between the transducers and the fruit called couplant which must be put in place to maximize the performance of the measuring techniques [7]. However, contamination between

the couplants may ruin the sample of the fruit. For other cases, the probe of the sensors needs to be placed extremely close to the fruit to obtain good response from the sample [10]. This process will increase the measuring time and leads to an inaccurate reading if the location of the sensor probe is not properly placed as desired. Measuring fruits with uneven skin surface also cannot be achieved using this kind of measuring method. Although imaging methods such as X-Ray and MRI give clear and accurate images, the extremely high cost of the measuring equipment limits the usage of the equipment for fruit quality monitoring.

In general, all the evaluation technique has its own advantages and disadvantages towards monitoring fruits' internal condition. However, it still gives great significant contribution towards agricultural industry globally.

## References

- [1] Kotwaliwale N, Kalne A, Singh K. *Monitoring of mango (Mangifera indica L.) (Cv.: Chousa) ripening using X-ray computed tomography*. Sixth International Conference on Sensing Technology (ICST). 2012: 326-330.
- [2] Mizrach A. Determination of avocado and mango fruit properties by ultrasonic technique. *Ultrasonics*. 2000; 38(1): 717-722.
- [3] Mizrach A. Assessing plum fruit quality attributes with an ultrasonic method. *Food Research International*. 2004; 37(6): 627-631.
- [4] Bechar A, Mizrach A, Barreiro P, Landahl S. Determination of mealiness in apples using ultrasonic measurements. *Biosystem Engineering*. 2005; 91(3):329-334
- [5] Suwannarat S, Khaorapapong T, Chongcheawchamnan M. Predicting Oil Content of Fresh Palm Fruit Using Transmission-Mode Ultrasonic Technique. *World Academy Science Engineering Technology*. 2011; 90110(9): 859-862.
- [6] Aboudaoud I, Faiz B, Aassif E, Moudden A, Izbaim D, Abassi D, Malainine M, Azergui M. *The maturity characterization of orange fruit by using high frequency ultrasonic echo pulse method*. IOP Conference Series Material Science Engineering. 2012; 42: 012038.
- [7] Lee S, Cho BK. *Evaluation of the firmness measurement of fruit by using a non-contact ultrasonic technique*. Proc. 2013 IEEE 8th Conference Industrial Electronic Application ICIEA. 2013: 1331-1336.
- [8] Lee S, Park J, Jeong H, Kim K, Cho B. Predicting the Firmness of Apples using a Non-contact Ultrasonic Technique. *Biosystem Engineering*. 2013; 38(3): 192-198.
- [9] Nicolaï BM, Beullens K, Bobelyn E, Peirs A, Saeys W, Theron KI, Lammertyn J. Nondestructive measurement of fruit and vegetable quality by means of NIR spectroscopy: A review. *Postharvest Biology Technology*. 2007; 46(2): 99-118.
- [10] Spinelli L, Rizzolo A, Vanoli M, Grassi M, Eccher P, Meirelles R. *Nondestructive assessment of fruit biological age in Brazilian mangoes by time-resolved reflectance spectroscopy in the 540-900 nm spectral range*. Inside Food Symposium. 2013: 9-12.
- [11] Zhang H, Huang J, Li T, Wu X, Svanberg S, Svanberg K. Studies of tropical fruit ripening using three different spectroscopic techniques. *Journal Biomedic Optics*. 2014; 19: 067001.
- [12] Bobelyn E, Serban AS, Nicu M, Lammertyn J, Nicolai BM, Saeys W. Postharvest quality of apple predicted by NIR-spectroscopy: Study of the effect of biological variability on spectra and model performance. *Postharvest Biology Technology*. 2010; 55(3): 133-143.
- [13] Hernández SN, Barreiro P, Ruiz CJ. On-line Identification of Seeds in Mandarins with Magnetic Resonance Imaging. *Biosystem Engineering*. 2006; 95(4): 529-536.
- [14] Barreiro P, Zheng C, Sun DW, Hernández SN, Pérez SJM, Ruiz CJ. Non-destructive seed detection in mandarins: Comparison of automatic threshold methods in FLASH and COMSPIRA MRIs. *Postharvest Biology Technology*. 2008; 47(2): 189-198.
- [15] Zhang L, McCarthy MJ. Measurement and evaluation of tomato maturity using magnetic resonance imaging. *Postharvest Biology Technology*. 2008; 67: 37-43.
- [16] Winisdorffer G, Musse M, Quellec S, Devaux MF, Lahaye M, Mariette F. MRI investigation of subcellular water compartmentalization and gas distribution in apples. *Magnetic Resonance Imaging*. 2015; 33(5): 671-680.
- [17] Kotwaliwale N, Singh K, Kalne A, Jha SN, Seth N, Kar A. X-ray imaging methods for internal quality evaluation of agricultural produce. *Journal Food Science Technology*. 2014; 51(1): 1-15.
- [18] Barcelon EG, Tojo S, Watanabe K. Relating X-ray absorption and some quality characteristics of mango fruit (*Mangifera indica L.*). *Journal Agriculture Food Chemical*. 1999; 47(9): 3822-3825.
- [19] IR Donis G, DE Guyer, DW Fulbright, A Pease. Postharvest noninvasive assessment of fresh chestnut (*Castanea spp.*) internal decay using computer tomography images. *Postharvest Biology Technology*. 2014; 94: 14-25.
- [20] Herremans E, Melado HA, Defraeye T, Verlinden B, Hertog M, Verboven P, Val J, Fernández VME, Bongaers E, Estrade P, Wevers M, Barreiro P, Nicolaï BM. Comparison of X-ray CT and MRI of watercore disorder of different apple cultivars. *Postharvest Biology Technology*. 2014; 87: 42-50.

- [21] Ohali YAI. Computer vision based date fruit grading system: Design and implementation. *Journal King Saud University-Computing Information Science*. 2011; 23(1): 29-36.
- [22] Pourdarbani R, Ghassemzadeh HR, Seyedarabi H, Nahandi FZ, Vahed MM. Study on an automatic sorting system for Date fruits. *Journal Saudi Society Agricultural Science*. 2015; 14(1): 83-90.
- [23] Unay D, Gosselin B, Kleynen O, Leemans V, Destain MF, Debeir O. Automatic grading of Bi-colored apples by multispectral machine vision. *Computational Electronic Agricultural*. 2011; 75(1): 204-212.
- [24] Mizushima A, Lu R. An image segmentation method for apple sorting and grading using support vector machine and Otsu's method. *Computing Electronic Agricultural*. 2013; 94: 29-37.
- [25] Guzmán E, Baeten V, Pierna JAF, García MJA. Infrared machine vision system for the automatic detection of olive fruit quality. *Talanta*. 2013; 116: 894-898.
- [26] Rajin SMAK, Abdul S, Anuar S, Muad M. Evaluation of the Quality of Grapes Using Machine Vision. *Recent Advance Intelligent Control Modelling Simulation*. 2013: 176-180.
- [27] Liming X, Yanchao Z. Automated strawberry grading system based on image processing. *Computing Electronic Agriculture*. 2010; 71(1): 32-39.
- [28] Nandi CS, Tudu B, Koley C. Computer Vision Based Mango Fruit Grading System. *International Conference on Innovative Engineering Technologies (ICIET'2014)*. 2014: 1-5.
- [29] Paynen AB, Walsh KB, Subedi P, Jarvis D. Estimation of mango crop yield using image analysis - Segmentation method. *Computing Electronic Agricultural*. 2013; 91: 57-64.
- [30] Mainland JD, Li YR, Zhou T, Liu WLL, Matsunami. H. Human olfactory receptor responses to odorants. *Science Data*. 2015; 2:150002.
- [31] Chiu SW, Tang KT. Towards a chemiresistive sensor-integrated electronic nose: a review. *Sensors*. 2013; 13: 10.
- [32] Sanaeifar A. Development and Application of a New Low Cost Electronic Nose for the Ripeness Monitoring of Banana using Computational Techniques (PCA, LDA, SIMCA, and SVM). *Czech Journal Food Science*. 2014; 32(6): 538-548.
- [33] Nouri F, Chen Z, Maqbool M. *Monitoring Mango Fruit Ripening after Harvest using Electronic Nose (zNoseTM) Technique*. 5th International Conference Food Engineering Biotechnology. 2014; 65: 8.
- [34] Kanade A, Shaligram A D. Development of an E-Nose Using Metal Oxide Semiconductor Sensors for the Classification of Climacteric Fruits. *International Journal Scientific Engineering Research*. 2014; 5(2): 467-472.
- [35] Hernández GA, Wang J, Hu G, García PA. Discrimination of storage shelf-life for mandarin by electronic nose technique. *LWT - Food Science Technology*. 2007; 40(4): 681-689.
- [36] Zhang B, Peng Xi W, Wen Wei W, Yuan Shen J, Ferguson I, Song Chen K. Changes in aroma-related volatiles and gene expression during low temperature storage and subsequent shelf-life of peach fruit. *Postharvest Biology Technology*. 2011; 60(1): 7-16.
- [37] Abbaszadeh R, Moosavian A, Rajabipour A, Najafi G. An intelligent procedure for watermelon ripeness detection based on vibration signals. *Journal Food Science Technology*. 2013; 52(2): 1075-1081.