

# A Lighting Control System in Buildings based on Fuzzy Logic

Seno D. Panjaitan<sup>1</sup> and Aryanto Hartoyo<sup>2</sup>

<sup>1,2</sup>Department of Electrical Engineering, Tanjungpura University  
Jln. Ahmad Yani Pontianak 78124, Indonesia, Ph./Fax: +62561-7050714/740168  
e-mail: senopanjaitan@engineering.untan.ac.id<sup>1</sup>, aryanto\_118@yahoo.co.id<sup>2</sup>

## Abstrak

Pencahayaan umumnya mengkonsumsi 25%-50% dari total energi listrik untuk sebuah gedung. Saat ini pencahayaan gedung didominasi oleh penggunaan lampu fluorescent. Publikasi-publikasi dari peneliti lain sebelumnya didominasi pada pengaturan densitas daya pada lampu pijar yang mulai jarang digunakan, tidak mempertimbangkan standar pada masing-masing negara sebagai referensi kendali, dan membutuhkan investasi yang mahal. Untuk itu, makalah ini menawarkan sebuah sistem pencahayaan berbasis logika fuzzy dengan otomatisasi lampu fluorescent untuk mencapai penerangan sesuai Standar Nasional Indonesia (SNI). Variabel masukan pengendali adalah nilai sensor cahaya dari luar dan dalam ruangan serta sensor keberadaan pemakai. Variabel keluaran adalah nilai pencahayaan diperlukan untuk mencapai nilai referensi. Nilai pencahayaan ini menentukan jumlah lampu yang harus dinyalakan oleh kontroler. Hasil pengujian pada sebuah kelas menunjukkan bahwa tanpa pengendali iluminasi terukur selama hari kerja sekitar 350 lux, sementara itu dengan pengendali bervariasi di sekitar 250-300 lux mendekati SNI (250 lux). Sementara itu, sistem pencahayaan dengan pengendali energi listrik lebih hemat 75% dibandingkan tanpa pengendali.

**Kata kunci:** kendali pencahayaan, otomatisasi gedung, fuzzy, iluminasi, manajemen energi

## Abstract

Lighting generally consumed 25%-50% of total electricity consumption in a building. Nowadays, the building lighting source is dominated by the use of fluorescent lamps. The previous technical papers by other researchers had focused on power density control of incandescent lamps, which is now rarely used, unconsidered national standard as control reference value, and required a high-cost in investment. By these reasons, this paper proposes a building lighting system based on fuzzy logic scheme to automate fluorescent lamps in order to achieve illumination according to Indonesian National Standard (SNI). The input variables were indoor lighting, inference from outdoor lighting, and occupancy. The output variable was the required illumination to achieve the standard. The required illumination determined the number of lamps that had to be turned on. In the experiment result, a classroom illumination of lighting without controller in workdays was about 350 lux, while with the proposed controller it varied between 250–300 lux close to the SNI, i.e. 250 lux. Meanwhile, with the proposed controller the electricity consumption for a classroom was 75% lower than the lighting without controller.

**Keywords:** lighting control, building automation, fuzzy, illumination, energy management

## 1. Introduction

The electricity demands increases so dramatically even more in the future. This phenomenon affects research focus of many researchers in order to provide a better solution for energy conservation. Technologies for energy efficient lighting systems have emerged since lighting contributes the highest amount of electricity usage in buildings. In general, lighting will consume 25% - 50% [1] of the electricity consumption. The use of lighting efficiently and effectively can offer major energy and cost saving. Many new technologies have emerged to convey energy efficient lighting by straightforward implementation. However, widening use of a new technology will be hindered if it is complicated to implement or there is uncertainty in the return of the investment. The research of energy efficient lighting systems therefore still becomes an open issue till now.

Energy lighting efficient research could be classified in three focuses: lamp technologies, lighting design and lighting control method. For lamp technologies, the research

focuses on energy efficient lamp products in terms of production cost and energy used such as light bulb/incandescent, fluorescent, and led. Lighting design investigates and analyses a proper energy management and presents a design for energy efficient lighting systems which has two main tasks, determine a suitable number of lamps or luminaires for specific room and the selection and replacement of lamps [1]. Meanwhile, lighting control method research addresses a theoretical and practical method to design artificial lighting network in order to have an energy efficient lighting system.

Lighting control is divided into building management system, automated control system with ability to switch off the light, automatic control system without the ability to switch off the light and manual control. However, its current technologies have not been commonly adopted with low percentage of the implementation. One of the reasons evaluated in [2] is 21% user difficult to understand the implemented technology. The other reason is the high price of the technologies. Moreover, there are only few papers related to lighting control method by other researchers that consider illumination standard in each country. A theoretical approach in [3] proposed a methodology to benchmark lighting energy consumption calculations for new building design or new lighting systems in existing building based on the German standard DIN 18599 and the North-American standard ASHRAE-IESNA 90.1. However, there is no technical paper that considers Indonesian or many other countries standard regarding lighting control method.

The current researches of lighting control focus on networking [4-7] and intellectualization of lighting control. The latter one differs in many applications such as stage lighting for theatrical performance [8] and highway tunnel lighting [9-10]. Other technical paper also investigated the implementation safety of lighting in hazardous area [11] and emergency lamps [12]. Furthermore, the existing published methods mostly used to control power density named dimmer [13-14] in order to reduce the consumption of electricity. Based on the survey in [15], using dimmers save 30% energy compared to conventional lighting systems with the similar type of lamp. An individual control of electric lighting manually can be seen in [16]. It is recommended to automate light power density control to enhance the saving. However, power density control is only applicable to incandescent lamps which need a high power for each lamp and now rarely apply as the main lamp type in buildings.

In fact, artificial lighting is dominantly used in buildings. The problem is then how to achieve the energy efficiency lighting in buildings zone using an uncomplicated and unsophisticated control, taking the most used lamp type in building into account and considering the national standard where the system implemented.

Fuzzy logic scheme has been commonly applied to provide a simple control in the implementation. There are numerous technical papers using modern approaches named fuzzy logic scheme for lighting control intellectualization [16-21] and other recent applications [22-24]. However, the applications of fuzzy logic in [16-19] focus on the power density control or dimmer to control illumination level that is only applicable for incandescent/light bulb lamps. Application on fluorescent lamps has been discussed in [20-21], but the focus of the papers are in charging and discharging of the lamps which are powered by Photo-Voltaic, not on the control of lighting based on those lamps. In fact, many commercial and institutional building commonly use fluorescent lamp type since it needs lower energy compared to incandescent/light-bulb lamps. Fluorescent lamps convert more of the input power to visible light than incandescent lamps. A typical 100 watt tungsten filament incandescent lamp may convert only 2% of its power input to visible white light, whereas typical fluorescent lamps convert about 22% of the power input to visible white light. Fluorescent lamp cannot be controlled by adjusting power density, but by on/off switching. Based on the literature study, there is no a lighting control method for fluorescent lamps yet regarding illumination level in building zone. By controlling the lighting system, the energy efficiency is enhanced. Besides, there is no technical paper that considers the inference of outdoor light source from the sun or other sources yet regarding the use of fluorescent lamps.

In this paper, fuzzy logic scheme is proposed as a basis to control lighting system in building zone where the fluorescent lamps are as the controlled objects. The proposed lighting design procedure determines the maximum number of lamps that should be used according to the room function. In the experiment, illumination level considered the Indonesian national standard named SNI 03-6197-2000 [25] as an illumination reference value. Then the proposed controller is activated and deactivated according to information from occupancy sensors, which

gives information about room occupancy. There are three new values composed in this paper: (1) a new automatic approach based on fuzzy logic scheme for building lighting control using fluorescent lamps, (2) a realization of the building lighting control which considers national standard as the reference value of the control target, (3) implementation of a low-cost control hardware using microcontroller based system. Using programmable microcontroller circuit assures the easiness of portability since it gives a simple way on installation and stand-alone operation. For controlling of more than one room lighting and for the easiness of handling, the control circuit can be expanded to multi-controller in the master slave control architecture.

## 2. Research Method

The procedure of lighting control system design (i.e. hardware and software) was focused on fuzzy logic scheme, testing and analysis.

### 2.1. Pre-definition of the System Requirements

The system requirements were defined in order to have control variables, parameters, and target based on the condition of controlled object. Some calculations and measurements were performed as follows:

1. *Determination of the minimum illumination level:* illumination level or number is quantity or light level in particular area (lux or lumen/m<sup>2</sup>). In this research, the experiment was performed to control illumination in a classroom as a controlled object where its minimum level was 250 lux based on Indonesian National Standard [25].
2. *Calculation of the average of illumination uniformity:* uniformity of illumination is important based on three reasons: to reduce various light density power in the room with similar activity, to provide a comfortable condition since the light power density could affect the productivity and visual comfort, and to satisfy users subjectively. In this research, average of illumination uniformity was determined at least 80% of minimum illumination standard for the controlled object. This value could be reached if the spacing criterion (SC) is fulfilled, that was ratio between center of armature (luminaries) and the distance to work place (mounting height). SC 1.5 means the maximum distance between light points is equal to 1.5 x mounting height. The average value of illumination uniformity is a minimum target once the system was implemented. The measurement result is then compared to the calculation.
3. *Calculation of lamp number to be applied to the controlled object:* to calculate illumination level in a room, this formula is used:

$$E = \frac{\phi \times CU \times LLF}{A} \quad (1)$$

where,

- E : Illumination level (lux)
- $\phi$  : Total illumination flux in the lighting area (Lumen)
- CU : Coefficient of Utility
- A : Space area of lighting (m<sup>2</sup>)
- LLF: Light Loss Factor

CU value depends on the reflectance and it is dominated by the value of floor reflectance. To measure reflectance in the controlled room, Lux meter was used. LLF involves the maintenance factors such as Lamp Lumen Depreciation, Luminaire Dirt Depreciation, and Room Surface Dirt Depreciation.

### 2.1. Hardware Design and Testing

In this research, all the lamps were located uniformly in the controlled room as shown in Figure 1. One of the light sensors was put close to windows to measure illumination as influence from outdoor and another one was in the middle to measure illumination produced by the lamps. The locations of these sensors were sample points of the measurement and their information

were used as input to the controller. Two entrance detectors were applied to activate or deactivate the lighting control system automatically based on the room occupation in order to save energy.

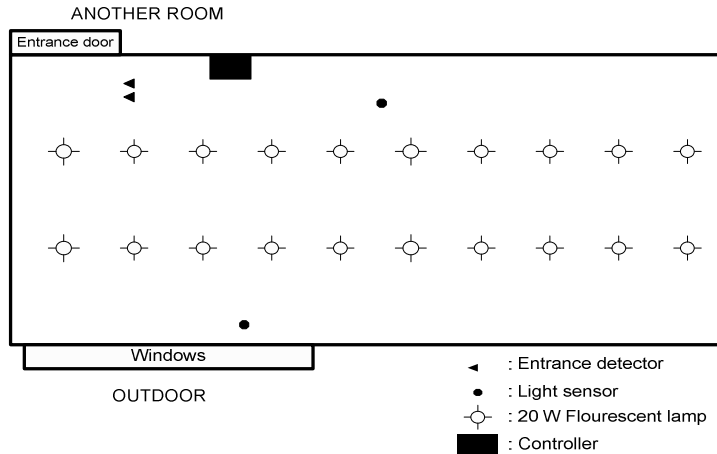

Figure 1. The position of lamps, sensors/detectors, and controller in the controlled room

The hardware controller design had several main elements, i.e. minimum circuit of microcontroller, signal conditioning, occupancy sensors circuit for entrance detectors, light sensors circuit, Analog-to-Digital (ADC), Detectors Module, Triode for Alternating current (TRIAC) circuit, and multiplexer circuit. The schematic diagram of the hardware controller is shown in Figure 2. Sensor signal which was an analog signal must be converted to digital prior the computation process in the microcontroller circuit. Therefore the ADC and multiplexer circuit were applied. For the output, TRIAC driver was implemented to turn on/off lamp(s) based on the signal from microcontroller.

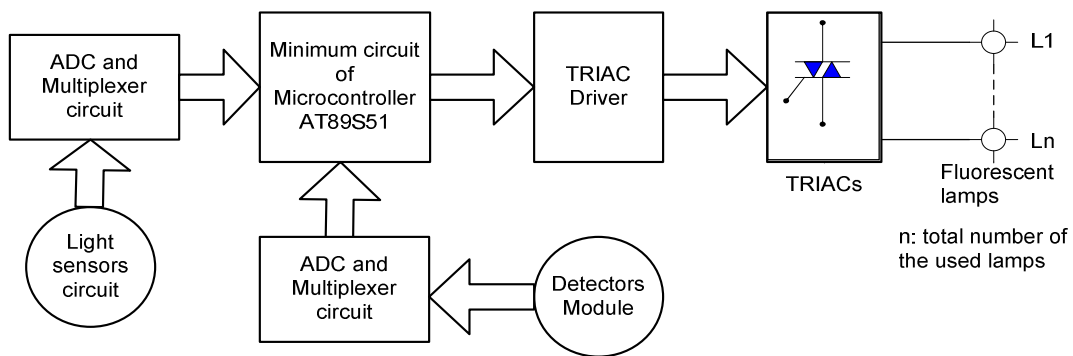

Figure 2. Schematic diagram of the proposed hardware controller

**2.2. Fuzzy Inference System (FIS)**

FIS is the procedure of formulating the mapping from a given input to an output using fuzzy logic. The mapping provides a basis from which decisions can be made. The input(s) and output(s) are modeled as membership functions (MF). The environmental light information from light sensors circuit in this research was used as input variable  $x_1$  (i.e. outdoor light sensor) and  $x_2$  (i.e. indoor light sensor). Figure 3 depicts the input variables using triangle functions. The output variable (see Figure 4) is the numerical value of extra illumination that is needed by room

to reach the illumination standard. This value was converted into number of additional lamps that should be turned-on. The fuzzy set of the output variable is inferred by max-min composition and the fuzzy relation describes the desired control action. The fuzzy set of the output variable is defuzzified to deliver a crisp numerical value by the centroid-of-area method.

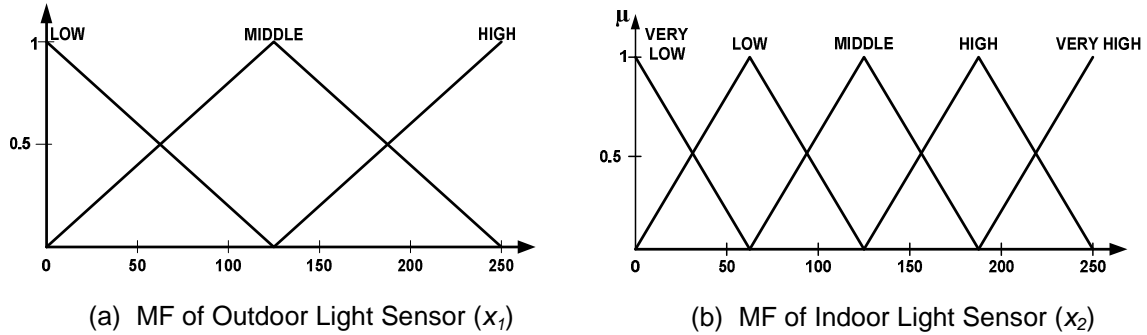

Figure 3. MF of Input Variables

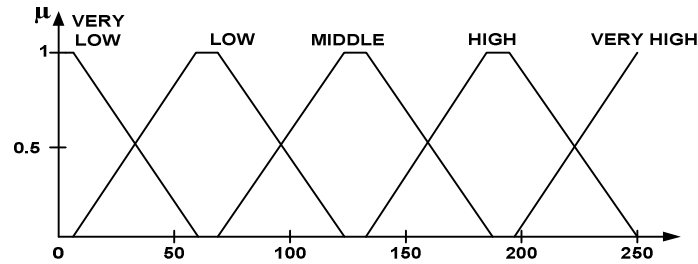

Figure 4. MF of Output Variable: required artificial illumination from lamps

The fuzzy rule base consists of a collection of fuzzy IF-THEN rules. In this paper, the rules are summarized in Table 1. The rules are stated as follows:

$$R(k): \text{IF } x_1 \text{ is } A_{1k} \text{ and } x_2 \text{ is } A_{2k} \text{ THEN } y \text{ is } Q_k$$

for  $k = 1, 2, \dots, n$

where  $x_1, x_2 \in U$ , and  $y \in R$  are the input and output of the fuzzy logic system, respectively,  $A_{1k}, A_{2k}$ , and  $Q_k$  are labels of fuzzy sets  $U_1, U_2$ , and  $R$  representing the  $k^{th}$  antecedent pairs and consequent pair respectively and  $n$  is the rules number of rules. For instance, IF  $x_1$  is LOW and  $x_2$  is VERY LOW THEN  $y$  is VERY HIGH (see Table 1).

Table 1. The fuzzy rules for the lighting control system

Input $x_1$	Input $x_2$				
	VERY LOW	LOW	MIDDLE	HIGH	VERY HIGH
LOW	Very High	High	High	High	Middle
MIDDLE	High	Middle	Middle	Middle	Low
HIGH	Middle	Low	Low	Low	Very Low

### 2.3. Programming Procedure and Testing

Programming of the FLC for the lighting control system was realized by using Software Assembler DT51S. The programming algorithm is as the following steps:

1. Initialization: Setting Port A (8 bit), Port B (8 bit), and Port C (4 bit) as outputs connected to TRIAC driver, Interruption from detector module (i.e. INT0, INT1), and setting variables.
2. Read the occupancy by reading the detector module, if there is no human then turn off all lamps, in vice versa, read light sensor data from INP3 and INP5 of microcontroller.
3. Based on the data INP3 and INP5, do fuzzy inference system in order to get the output based on the real data of light sensors.
4. Step 2 and 3 are continuously updated until the manual intervention from human is given to turn off the system.

The testing was performed to validate the system operation according to the given control scenario.

### 2.4. Analysis of System performance

Analysis was divided into sub-analysis of the following properties: components of control system (sensors, module detector, multiplexer, ADC), simulation results from the FIS, and Illumination level from the measurement in the controlled room. The last sub-analysis activity concluded the performance of system by means of the capability to reach the control target.

## 3. Results and Discussion

Number of lamps used for lighting control system was determined by calculating total illumination flux in the lighting area. It was determined that  $E=250$  lux,  $CU=0,69$ ,  $A=43,29$  m<sup>2</sup> (measurement result of room dimension), and  $LLF = 0,8$ . From equation (1) we got,

$$\phi = \frac{E \times A}{CU \times LLF} = \frac{250 \times 43.29}{0.69 \times 0.8} = 19605.98 \text{ Lumen} \quad (2)$$

Each 20 Watt fluorescent lamp used in the experiment could produce 1100 Lumen in new condition. Thus, number of the required lamps was  $19605.98 / 1100 \approx 18$  lamps. The other type of lamp with different kind of power and intensity could be used with the related computation.

The first data in the experiment was testing results of each component. Figure 5 shows the developed lighting control system. The controller consisted of five elements: detector module, light sensor, multiplexer, ADC, and main control (i.e. microcontroller circuit). The testing result of detector module was the value at counter which was saved in 8 bit register and had counting limit until  $2^8$  or 256. It meant that maximum entrance/exit counting was 256 persons.

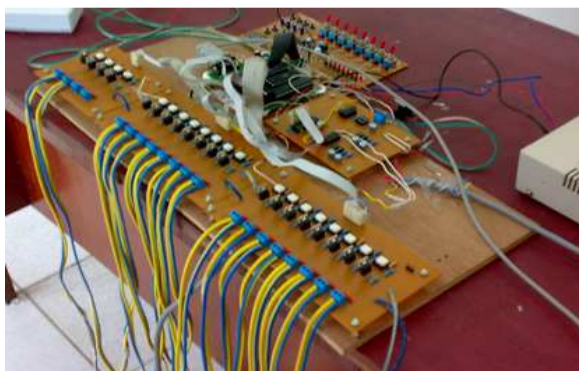

(a)



(b)

Figure 5. The Developed System: (a) Prototype of the controller, (b) part of controlled room

The testing points for light sensors, multiplexer, and ADC were illustrated in Figure 6. The Light Dependent Resistor (LDR) was the main component in light sensors. The testing was performed to know the lowest and the highest value of the sensor regarding the illumination level 0 and 250 lux respectively. Two light sensors had different value, for outdoor light sensor, output voltage range of the sensor was 0,194 – 4.64 volt related to illumination between 0 – 250 lux, while for indoor light sensor the output voltage range was 0.27 – 3.19 volt related to illumination between 0 – 250 lux. In the multiplexer circuit, the testing worked well, where the logical combination was correct.

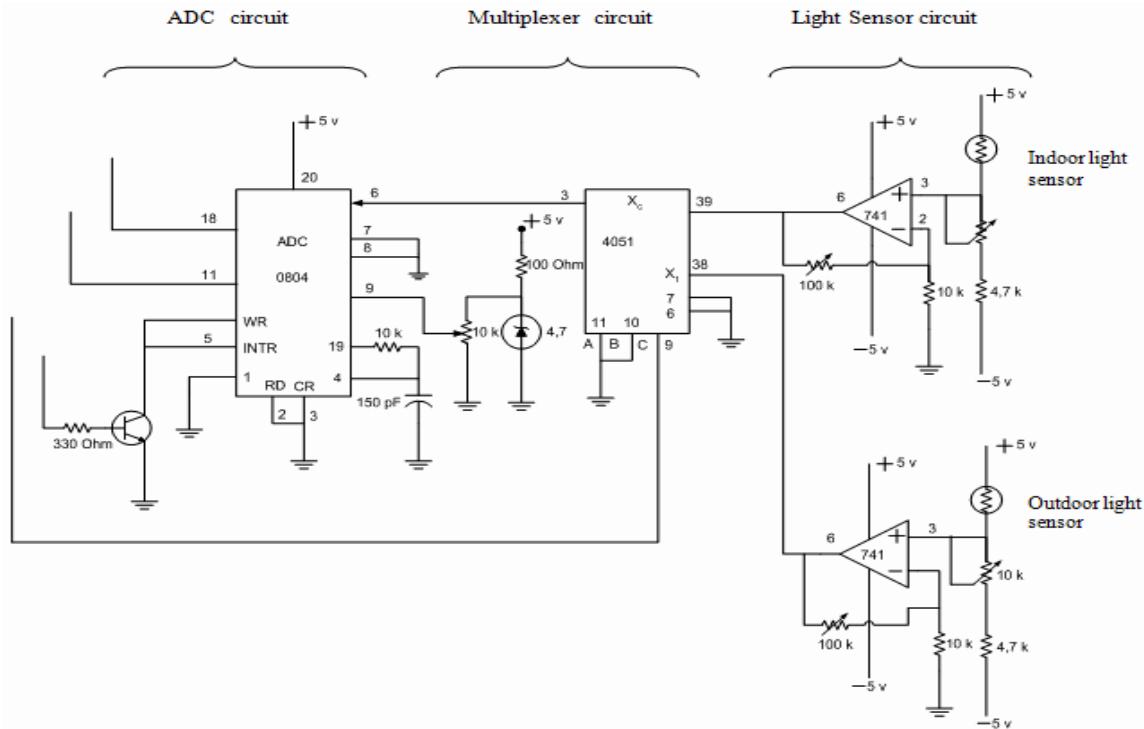

Figure 6. Measurement points of light sensors, ADC, and Multiplexer

The simulation results of the fuzzy inference system based on the given MF of input variables (i.e. light sensors) and output variable (i.e. required illumination value) consists of two parts: rules and surface view. Figure 7 shows the results of the simulation of the rule base by fuzzy inference development environment (MATLAB Fuzzy Logic Toolbox) software for the input value of the environmental light  $x_1 = 63.1$  and  $x_2 = 51.1$ . The output is 158 where the number of lamps that must be turned on was  $(158/250) \times 18$  lamps  $\approx 12$  lamps. There were 15 rules with AND relations between antecedents ( $x_1$  and  $x_2$ ) and one consequence ( $y$ ). The surface view shown in Figure 8 is the control surface. It means that for every possible value of the two inputs, there is a corresponding output based on the rules. For instance, if the environmental lights  $x_1$  and  $x_2$  are given, the required illumination value ( $y$ ) of the system to adjust the lighting to reach the illumination standard can be obtained immediately.

The measurement has been done in twelve measurement points which were located the Luxmeter symmetrically in the controlled room. The total number of the used lamps (i.e. 20 W fluorescent lamps) based on the calculation in section 2.1 was 18 lamps with 1100 lumen for each lamp in a new condition. The variation of illumination affected the number of lamps that must be turned-on. The average of illumination in the controlled room is 260.36. When all windows closed, the average illumination in the controlled room is 19.76 lux. Thus, the controller turned on 17 lamps to gain the illumination and based on the measurement the average illumination was gained to 255.5. The other results prove quantitatively that the more space of the outdoor light can affect the controlled room, less lamp(s) that must be turned on and vice versa.

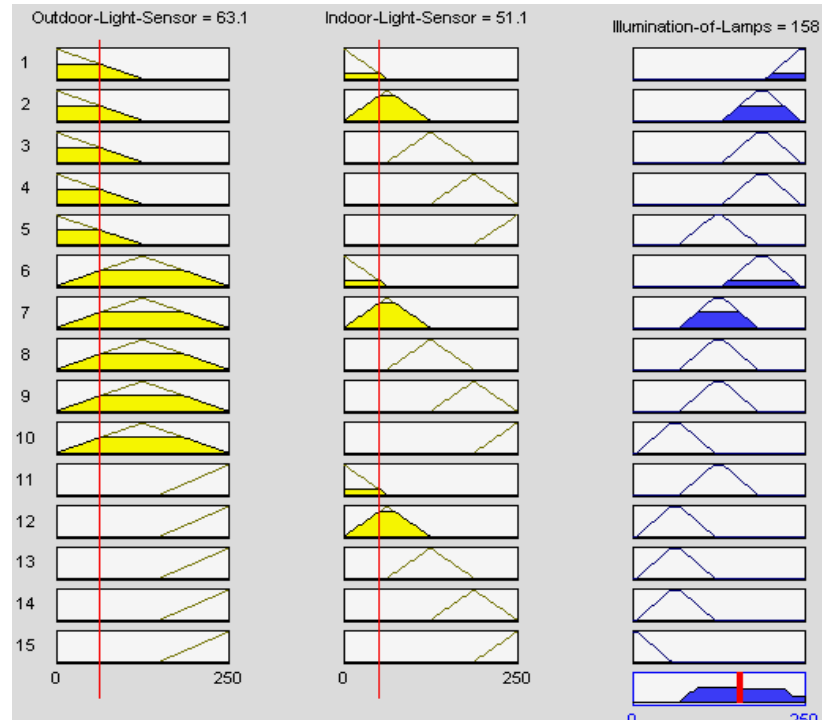

Figure 7. Simulation results of the FIS: rules view

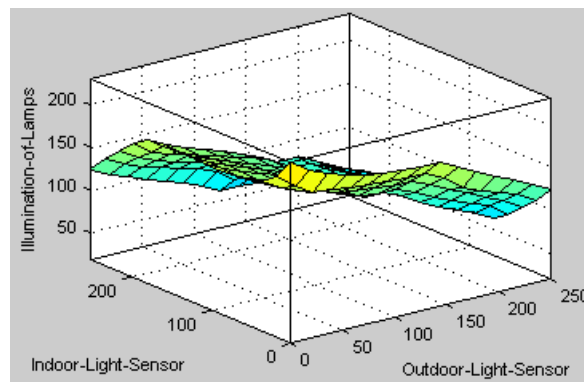

Figure 8. Simulation results of the FIS: surface view

Figure 9 shows the comparison of the illumination of the controlled room: with and without controller. With controller means that the lighting system in the room controlled based on the proposed approach, while without controller means that the room using the lighting design in the installation but without a controller to automate the lighting. The experiment has been performed in work time (Monday until Friday, 08.00 – 17.00) in two weeks based on the same scenario of the lecturer schedule. The lighting system without controller shows the higher illumination than the Indonesian national standard [25] for class room, i.e. 250 lux, even more than 350 lux in Thursday and Friday, while with controller the illumination is around the standard.

In terms of the energy saving, Figure 10 shows the measurement of the energy consumed with similar two options as mentioned before: with and without controller. It can be seen that the electricity consumed each work day is more than 16 kWh for the lighting without controller. With the proposed controller, the used electricity is around 4 kWh which is 75 % more efficient compared to the scenario without controller.



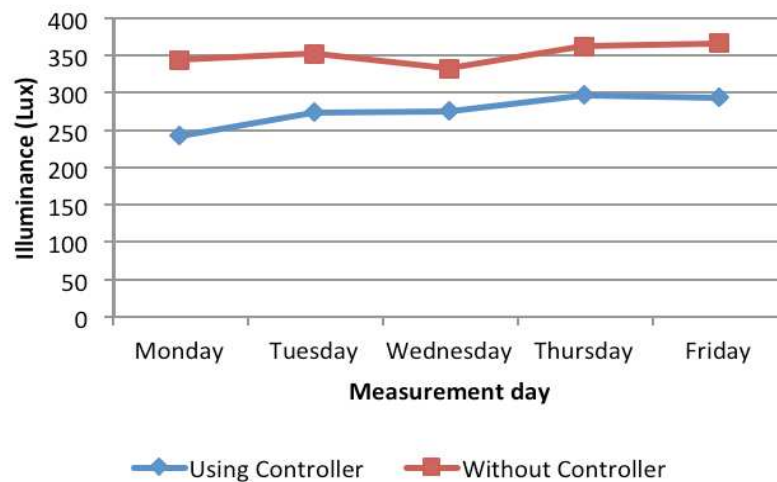

Figure 9. Illumination of the controlled room: with or without controller

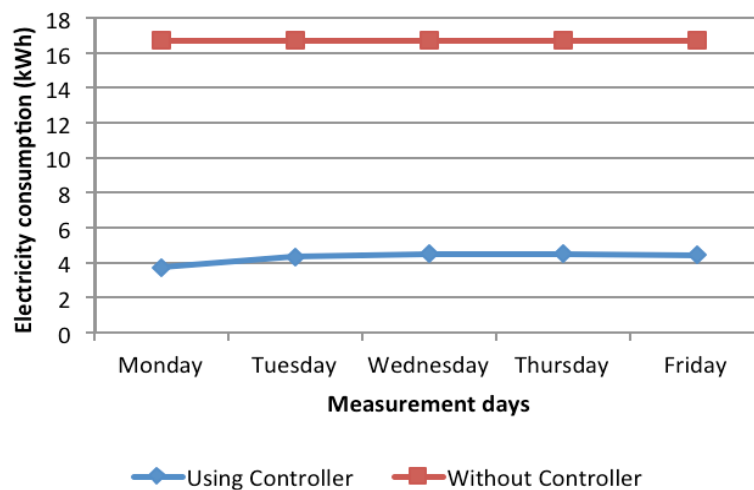

Figure 10. Energy consumed: with or without controller

#### 4. Conclusion

This paper proposes a fuzzy logic controller to automate the on/off florescent lamps which is now commonly used in buildings. These lamps cannot be dimmed individually, but the control of them means to control the illumination in buildings. Since there is no a method to control the on/off fluorescent lamps yet, the research results presented in this paper becomes important. The proposed controller is low-cost in terms of investment and operational since a microcontroller circuit has been used. In the fuzzy inference system, two MF was used for input variables and one for output variable. There were 15 rules for deciding the output function based on the input variable values. In the experiment result using the developed prototype, a class room illumination of lighting without controller in work days was about 350 lux, while with the proposed controller it varied between 250–300 lux close to the SNI, i.e. 250 lux. Meanwhile, with the proposed controller the electricity consumption was 75% lower than the lighting without controller. This result proves that the proposed controller saves more energy and gives the illumination closer to the Indonesian standard (i.e. SNI) compared to the conventional lighting system.

## References

- [1] Muhammad WNWZ, Zain MYM, Wahab N, Aziz NHA, Kadir RA. *Energy Efficient Lighting System Design for Building*. IEEE Intl. Conference on Intelligent systems, Modelling and Simulation (ISMS). Liverpool. 2010: 282-286.
- [2] Doulos L, Tsangrassoulis A, Topalis FV. *Evaluation of Lighting Controls in Office Buildings*. 6th WSEAS Intl. Conference on Circuits, Systems, Electronics, Control, and Signal Processing. 2007: 69-77.
- [3] Rosemann A, Suvagau C. *Methodology to Calculate the Energy Consumption for Lighting in Buildings*. 8<sup>th</sup> IEEE Annual Electrical Power & Energy Conference (EPEC). Vancouver. 2008: 1-4.
- [4] Diaz J, Rodriguez E, Hurtado L, Cacique H, Vazquez N, Ramirez A. *CAN Bus Embedded System for Lighting Network Application*. 51<sup>st</sup> IEEE Intl. Midwest Symposium on Circuit and Systems (MWSCAS). Knoxville. 2008: 531-534.
- [5] Wen YJ, Agogino AM. *Wireless Networked Lighting Systems for Optimizing Energy Savings and User Satisfaction*. IEEE Wireless Hive Network conference (WHNC). Texas. 2008: 1-7.
- [6] Park TJ, Hong SH. Experimental Case Study of a BACnet-Based Lighting Control System. *IEEE Transactions on Automation Science and Engineering*. 2009; 6(2): 322-333.
- [7] Cheng CA, Cheng HL, Lin KJ, Chu KL, Yen CH. *A Digitally Wireless Dimmable Lighting System for Two-Are Fluorescent Lamps*. Technical Conference (TENCON) IEEE Region 10. Fukuoka. 2010: 2173-2178.
- [8] Jiang W, Jiang Y, Ren H. *Analysis and Prospect of Control System for Stage Lighting*. 3<sup>rd</sup> IEEE Congress on Image and Signal Processing (CISP). Yantai. 2010: 3923-3928.
- [9] Yong Y, Zuojun B, Chunzheng Z, Lei W. *Study on the Mesopic Vision Theory used in Road Tunnel Lighting Measurement*. 3<sup>rd</sup> IEEE Conference on Measuring Technology and Mechatronics Automation (ICMTMA). Shanghai. 2011; 3: 565-567.
- [10] Huang T, Luo F, Zhang K. *Application of Fuzzy Control to A Road Tunnel Lighting System*. 6<sup>th</sup> IEEE Conference on ITS Telecommunications (ITST). Chengdu. 2006: 136-139.
- [11] King M, Hur D, Wisniewski B. Hazardous Area Lighting, Temperature Considerations, New Protections Methods, Technology and Illumination. *IEEE Industrial Applications Magazine*. 2009; 15(4): 66-75.
- [12] Baggini A, Granziero M, Bua F, Cappellari M. *Characterisation of CSS Supplied Emergency Lighting Equipment Characterization of most common emergency lighting sources behaviour in terms of in rush current*. 9<sup>th</sup> IEEE Conference on Electrical Power Quality and Utilisation. Barcelona. 2007: 1-5.
- [13] Yan W, Hui SYR. *Dimming Characteristics of Large-scale High-Intensity-Discharge (HID) Lamp Lighting Networks using a Central Energy-Saving System*. IEEE Industry applications conference 41<sup>st</sup> IAS Annual meeting. Tampa. 2006; 3: 1090-1098.
- [14] Boyce PR, Veitch JA, Newsham GR, Jones CC, Heerwagen J, Myer M, Hunter CM. Occupant use of switching and dimming controls in offices. *Lighting Research and Technology*. 2006; 38(4): 358-376.
- [15] Newsham GR, Aries MBC, Mancini S, Faye G. Individual control of electric lighting in a daylight space. *Lighting Research and Technology*. 2008; 40(1): 25-41.
- [16] Kolokotsa D. Comparison of the performance of fuzzy controllers for the management of the indoor environment. *Building and Environment (Elsevier)*. 2003; 38(12): 1439-1450.
- [17] Hagrais H, Callaghan V, Colley M, Clarke G. A Hierarchical Fuzzy Genetic Multi-Agent Architecture for Intelligent Buildings Learning, Adaptation and Control. *Information Sciences (Elsevier)*. 2003; 150(1-2): 33-54.
- [18] Jin M, Ho M. Labview-based Fuzzy Controller Design of A Lighting Control System. *Journal of marine science and technology*. 2009; 17(2): 116-121.
- [19] Cziker A, Chindris M, Miron A. *Implementation of Fuzzy Logic in Daylighting Control*. IEEE Conference on Intelligent Engineering Systems (INES). Budapest. 2007: 195-200.
- [20] Wu TF, Chang CH, Chen YH. *A Fuzzy Logic Controlled Single-Stage Converter for PV Powered Lighting System Applications*. IEEE Industry applications conference 34<sup>th</sup> IAS Annual meeting. Phoenix. 1999; 3: 1685 – 1692.
- [21] Wu TF, Chang CH, Chen YH. A Fuzzy-Logic-Controlled Single-Stage Converter for PV-Powered Lighting System Applications. *IEEE Transactions on Industrial Electronics*. 2000; 47(2): 287-296.
- [22] Nasution H. Development of Fuzzy Logic Control for Vehicle Air Conditioning System. *TELKOMNIKA Indonesian Journal of Electrical Engineering*. 2008; 6(2): 73-82.
- [23] Rasdi M. Kesesuaian Metoda Fuzzy Auto-regressive untuk Model Curah Hujan di Indonesia. *TELKOMNIKA Indonesian Journal of Electrical Engineering*. 2010; 8(1): 35-40.
- [24] Suardinata, Bakar KBA. A Fuzzy Logic Classification of Incoming Packet for VoIP. *TELKOMNIKA Indonesian Journal of Electrical Engineering*. 2010; 8(2): 165-174.
- [25] Badan Standar Nasional (BSN). *SNI 03-6197-2000: Konservasi energi sistem pencahayaan pada bangunan gedung*. BSN Press. 2000.