

Investigating the Intelligent Methods of Loss Minimization in Induction Motors

Sadegh Hesari^{*1}, Mohsen Noruziazghandi², Ali Asghar Shojaei³, Mehdi Neyestani⁴

¹Bojnourd Branch, Islamic Azad University, Bojnourd, Iran

^{2,3}Department of Electrical Engineering, Neyshabur Branch, Islamic Azad University, Neyshabur, Iran

⁴Esfarayan University of Technology, North Khorasan, Iran

*Corresponding author, e-mail: sh.university@yahoo.com

Abstract

Induction motors are widely used in industry. Given the increasing demand for electric machines in different industries, optimization of these machines to achieve a high efficiency with low cost is of utmost importance. Loss-minimization in motor is done in three ways: 1) optimizing motor selection and design; 2) improving motor power supply waveforms; and 3) using appropriate controlling methods in drives. Often, inductive motors provide the maximum efficiency in their nominal load. In most applications it is necessary for a motor to work in light loads for a long time, e.g. in conveyors, elevators, etc. In these conditions, the machine load is not the nominal load, and a higher percentage of the input power is lost. So, in the case of variable load, the first and second methods cannot increase the efficiency; but the third method provides a large flexibility in decreasing motor losses. In this paper, the application of the third method in loss-minimization is reviewed. These motor losses are mostly related to the controlling strategy and basically occur in light-load conditions. There are various strategies to decrease this kind of losses, which are generally divided into two categories: classic methods and intelligent methods. In this paper, first the classic methods, including losses model control (LMC), flux control as a function of torque and search control (SC), are discussed. Then the intelligent methods, such as genetic algorithm, PSO, fuzzy logic and artificial neural network are investigated. This paper is presented while the last methods of efficiency improvement are being investigated and each method is described briefly.

Keywords: loss minimization, efficiency improvement, inductive motors, intelligent methods, d-axis current, q-axis current.

Copyright © 2018 Universitas Ahmad Dahlan. All rights reserved.

1. Introduction

Electrical machines are among of the oldest and most basic equipment in power industry. Since the emergence of the power industry up to now, they have undergone several revolutions and upheavals. During all these years, these upheavals have been directed toward improving performance conditions as well as reducing the construction costs. However, the speed with which these revolutions occur is a function of the secular and economic situations of different nations around the world. In recent years, given the high costs of energy production, energy-saving and loss-minimization in different equipment in order to increase their efficiency has been considered extensively. Generally, the electric machines fall in the category of nonlinear energy conversion instruments, i.e. every change in the input does not always lead to the same proportion in the output. There is no doubt that the electric machines are the primary and most important driving elements in industrial, medical, and domestic machines, etc. which are changing continuously. Each electric machine is designed with a certain objective in mind, and ultimately the designer is seeking a design that can respond to the desired needs and is optimal in output characteristics and efficiency. Among different kinds of electric machines, due to their special advantages, simple and firm design, low cost, low maintaining costs, etc., induction motors have been used in many industrial applications, including industrial movement control systems, as well as domestic applications.

In recent decades, much efforts has been allocated by researches to achieve an appropriate method for optimizing different electric machines, which has resulted in methods such as Genetic Algorithm (GA), Particle Swarm Optimization (PSO), Artificial Neural Networks (ANN), and Fuzzy Logic. Artificial intelligence was employed for the first time by John McCarty [1], known as the father of "the science of intelligent machines". An intelligent system is a goal-oriented

device that solves a problem artificially. Artificial intelligence is a very complicated and profound science, introduced in the last century, and generally studies the information, the way this information is gathered and maintained, the employment of the information, and its transference into a machine or human. In each section of this research, first the fundamentals of each intelligent method are described. Then the structure of each system is explained, which is to be optimized in electric machines. The previous works on intelligent systems in induction motor drives are discussed and compared, and finally their advantages and disadvantages are presented.

The rest of this paper is organized as follows: in Section II the classic methods, including flux search controller (SC), flux control as a function of torque and LMC method, are introduced. In Section III the intelligent methods are investigated. Section III.A describes the use of Genetic Algorithm to optimize the losses. Section III.B presents PSO algorithm. Section III.C describes the use of Fuzzy system in a drive, and section III.D provides the structure of an artificial neural network in drives. Also, section IV discusses the performances of these methods and finally, section V concludes the paper.

2. Classic Methods

Currently, electric motors account for more than 60% of the total energy consumption. Due to the environmental concerns, the electric drives should have a high efficiency. Losses in induction machines include rotor and stator copper losses, iron losses, stray losses, and friction and ventilation losses. Copper, iron and stray losses account for about 90% of the total losses, and the other 10% is ascribed to friction and ventilation losses. When the machine works in a light load, the balance between copper and iron losses is disturbed and the motor efficiency falls, because in light loads iron losses constitutes the major part of the total losses [2]-[5]. In this case, an appropriate controlling method can be used to decrease this loss in the motor drive. Generally, all the controlling methods are trying to create a balance between electric and magnetic efficiency. As it was mentioned, motors can have a maximum efficiency in their nominal conditions. Therefore, when the load is lower than the nominal conditions, the motor flux can be controlled. The flux variations in relation to load can be divided into three states: 1) flux search controller (SC); 2) flux controller as a function of torque; and 3) flux control based on losses model controller (LMC). Each of these categories is elaborated in the next subsections.

2.1. Flux search controller

In this method, the drive searches for a operational point with maximum efficiency and sets the operational point in it. This method works like this: the input power is read easily by wattmeter, then the motor supply voltage or frequency changes one scale, and the new power input is compared to the previous one, thereby the drive controller conducts the drive to the operational point where the minimum power input can be achieved. A speed control ring is necessary in this drive in order to stabilize the output power when the input power and motor speed are lowered, which increases the motor efficiency.

There is no need to any information about motor parameters in this method. The main deficit of this method is its requirement of speed measurement. Since in this method, no motor parameter is used, so there is no error in finding the optimal operational point in different working conditions, and the real loss point is always found easily. In addition, the input power can be measured from the drive, which results in the simultaneous minimization of the total system losses, including motor, inverter, filter, and rectifier losses. The main problem in SC method is its low convergence and high torque ripple [6]. In this method, one of the drive variables is selected as the objective function and then the objective function is reduced in a successive step by regulating the flux amount. Figure 1 shows the basics of this method. The stator flux moves from the initial value ($|\psi_s|_0$) to its final value ($|\psi_s|_{opt}$) in order to minimize the objective function. The controlling algorithm is given in (1) [3].

$$\begin{aligned} |\psi_s|_2 &= |\psi_s|_1 + \Delta\psi \\ \text{If } (|\psi_s|_2 > |\psi_s|_1) & \text{ then } \Delta\psi = -\Delta\psi \end{aligned} \quad (1)$$

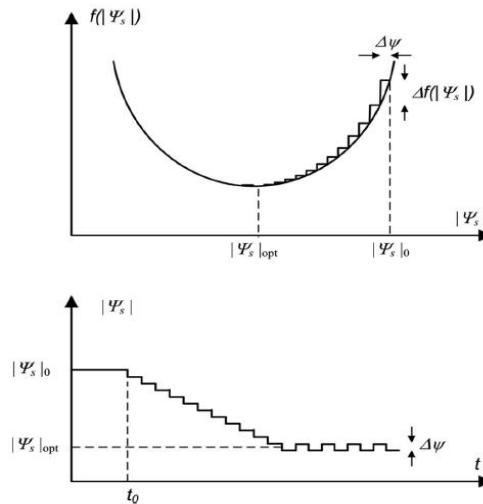

Figure 1. The basics of flux search controller method [3]

2.2. Flux control as a function of torque

This method has been proposed by Takashi, Noguchi in [7]. In this method, the domain of flux is a function of torque, which is given in (2) [4].

$$|\psi_s| = |\psi_{sn}| \sqrt{\frac{T_e}{T_{en}}} \tag{2}$$

Where ψ_{sn} and T_{en} are stator flux and torque nominal values, respectively. This method has many advantages over other methods, including elimination of transfer to a different coordinates, the lowest dependence on machine parameters, no need to direct control for stator Current and faster dynamic response. Also, as a well-known technique in industry, it is used because of its simplicity. Nevertheless, it cannot be trusted as a sign of power loss in drive, and it cannot find the optimal amount of flux. Therefore, its result can only lead to a modest improvement in motor efficiency [2]-[3].

2.3. Flux control based on losses model (LMC)

In LMC method, the machine model is used to calculate the losses. Therefore, in contrast to the previous methods, we need accurate information about the machine parameters [6]. In this method, the optimal point is obtained by the machine parameters through some calculations, and the controller places the machine in that operational point. Previous studies show that enormous mathematical calculations and complexities required in measuring the required parameters in this method make it a difficult one to model the losses. However, this method is faster and does not include torque ripple. In order to have a better description of this method, often an equivalent model, referred as the magnetic current, is used. An iron losses resistance R_f is added in parallel with magnetic inductance in the rotor flux reference frame, which is shown in Figure 2 [6,8].

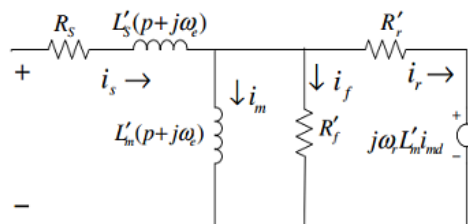

Figure 2. Space vector equivalent circuit in a rotor-flux-oriented reference frame including an iron loss resistor [8]

The stator copper losses, the rotor copper losses, and iron losses, altogether represent the total losses as (3):

$$P_{total} = P_{cus} + P_{iron} + P_{cur} = R_s(i_{sd}^2 + i_{sq}^2) + R'_f(i_{sq} + i_r) + R'_r i_r^2 \quad (3)$$

Where, p_{cus} is the stator copper losses, p_{iron} is the iron losses and p_{cur} is the rotor copper losses. When we have only the stator voltage and current as the real variables, the total losses should be obtained in terms of i_{sd} and i_{sq} currents. From Figure 3, the rotor current is:

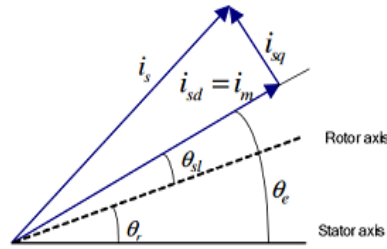

Figure 3. Phasor diagram of equivalent circuit and rotor field angle definition [8]

$$i_r = \frac{R'_f}{R'_f + R'_r} i_{sq} - \omega_r \frac{L'_m}{R'_f + R'_r} i_{sd} \quad (4)$$

Substituting (4) in (3), the total losses is:

$$P_{total} = R_d i_{sd}^2 + R_q i_{sq}^2 \quad (5)$$

$$R_d = R_s + \frac{L_m^2}{R'_f + R'_r} \omega_r^2, R_q = R_s + \frac{R'_f R'_r}{R'_f + R'_r}$$

The torque equation is:

$$T_e \cong \frac{3}{2} Z_p L'_m i_{mr} i_{sq} = K_t i_{mr} i_{sq} \quad (6)$$

In permanent state, we have:

$$i_{sq}(i_{sd}) = \frac{T_e}{K_t i_{sd}} \quad (7)$$

The losses equation in (5) is summarized as (8):

$$p_{total} = R_d i_{mr}^2 + R_q \frac{T_e^2}{K_t^2 i_{mr}^2} \quad (8)$$

In order to have the least losses, the derivative of (8) should be obtained:

$$\frac{d P_{total}}{d i_{mr}} = 0 \text{ then } i_{mr} \quad (9)$$

A problem in LMC method is the variable motor parameters like R_q and R_d , as well as its differentiation operations. In order to remove the problem of parameters in LMC method, online parameter estimation is a good solution, presented in [6, 8]. Applying such a method leads to a timely motor control. As such, In order to resolve these two deficits, using intelligent methods has also been experimented, which is the topic of the next few sections. In permanent state, there is no leakage inductance on the motor and the motor equivalent circuit is shown in Figure 4.

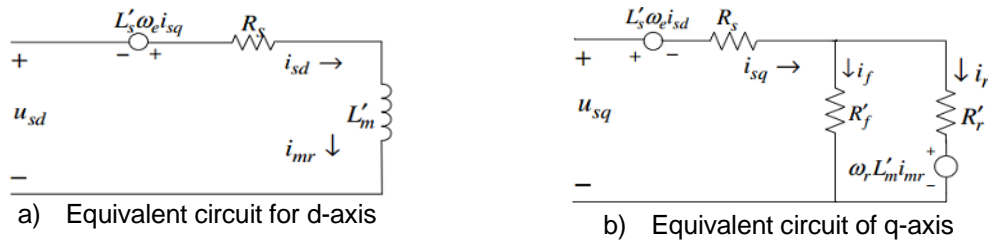

Figure 4. Steady-state IM equivalent circuit in: (a) d-axis and (b) q-axis [8]

3. Intelligent Methods

In this section, we investigate the works conducted in the field of induction motor optimization using intelligent methods. The references of this section show that there are extensive discussions regarding the induction motor efficiency and these motors are employed in different industries. In describing the previous works, it will be observed that the optimizations are quite various and are applied to several motor parameters. These researches indicate that, although different algorithms have been used to optimize the motors, the ultimate goal of all the researches is to obtain a high efficiency and output with a cheaper motor design. Also, different states of intelligent methods, relying on classic methods, are employed. All the three classic methods presented in section 2 are used in different ways in the optimization process. In next sections each intelligent method is elaborated, including Genetic Algorithm, PSO algorithm, Fuzzy Logic and Artificial Neural Network. The combined methods of Fuzzy-Genetic, Fuzzy-PSO, Genetic-Neural Network and PSO-Neural Network are also analyzed, which may have a better performance in increasing the motor efficiency.

3.1. Genetic algorithm

The genetic algorithm was presented by John Holland in Michigan University in 1975. In 1992, John Koza also used the genetic algorithm to solve and optimize complex engineering problems, and managed to computerize the genetic algorithm procedure. In genetic algorithms, first some random solutions are produced for the problem. This set of solutions is called initial population. Each solution is called a chromosome. Then, after selecting the better chromosomes and using the genetic algorithm operators, the chromosomes are combined and a mutation is triggered in them. Finally, the present population is combined with the new population obtained from the combination and mutation in chromosomes. One popular method for finishing the algorithm is to stop it after producing a certain number of generations. Since in some operators the number of generations should be known, this method seems useful. When the algorithm iterations reached to the desired number of generations for the algorithm input, the final answer quality is examined. If the desired answers are not met, the algorithm will continue till another certain number is achieved, or it will start over with a different population arrangement and maybe some new settings.

One problem that existed in LMC was to use differentiation, while the genetic algorithm does not need differentiation and/or any type of auxiliary information, and only the objective function and the fitness determinant style for raw information should be specified for search [9]-[10]. In [11-13,16] the genetic algorithm has been used to Minimize Losses. The main approach of this paper is to optimize the flux level and/or d-axis current. Since the problem of LMC method was differentiation, so in this references this problem is solved by finding the minimum, which is an easier solution. Equation (9) is rewritten as (10):

$$\text{Min } P_{total} \quad (10)$$

Regarding this, some currents from i_{mr} are chosen that has the minimum losses (in nominal state i_{mr} current is equal to d-axis current, i.e. the motor i_d). The structure of these references is illustrated in en dash lines in Figure 5.

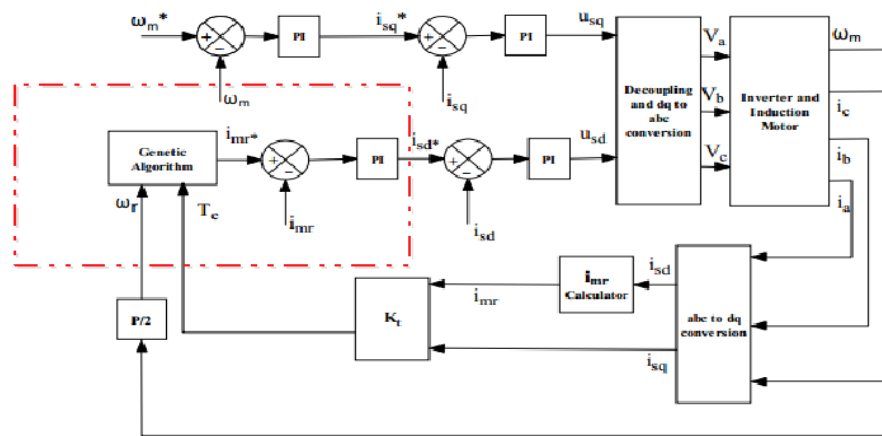

Figure 5. The model block diagram

The loss optimization flowchart with GA is shown in Figure 6.

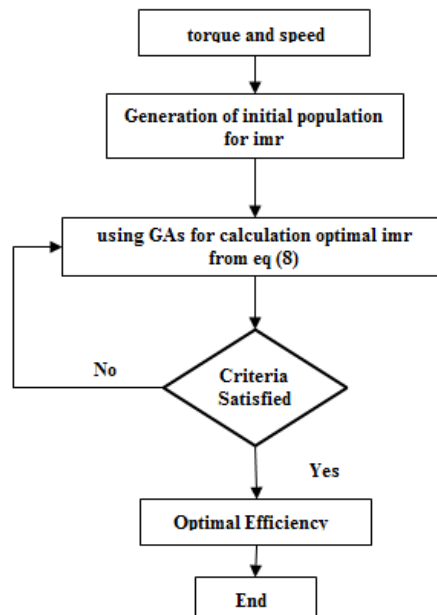

Figure 6. The loss optimization flowchart

The genetic algorithm stages in these references are:

- a. Producing the Random initial population
- b. Evaluating the objective function (8)
- c. Reproduction: parents from the largest objective function to the smallest categorized amount. The excellent people can pass to the next stage without any variation.
- d. Crossover and mutation (new children)
- e. Return to stage 2

This method has been applied on motors having 1 to 10 kw capacity. In each of them in low-load conditions, The Efficiency has increased to more than 60%. For example, Figure 7 show the result of GA application in a 9-kW motor. As it can be seen from the figure, The Efficiency in different working conditions, even in low-load state, has reached 92%. (The vertical axis varies in percentage scale and the horizontal axis (motor output power) varies in Watt scale).

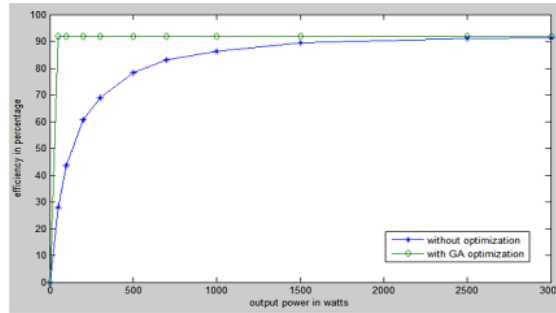

Figure 7. The motor efficiency in optimization and without optimization states

In [14]-[15], PID Tuning GA controller is used to improve the performance of induction motor drive. The basic structure of the GA Tuning controller is shown in Figure 8.

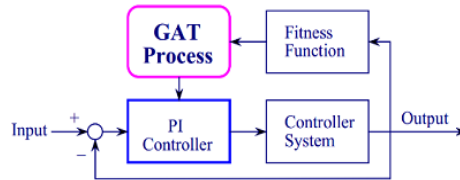

Figure 8. The model block diagram

In fact, the PI controller parameters, like k_p and k_i , are directly regulated by GA. The way this approach works can be seen in the motor drive speed control system. Figure 9 shows the diagram of an induction motor drive.

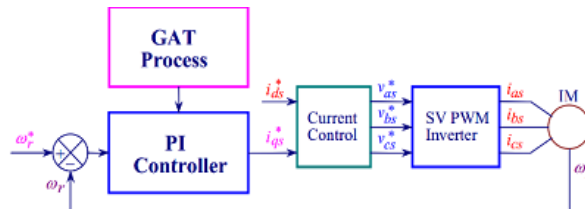

Figure 9. The model block diagram

As it can be seen in Figure 9, the GA process affects k_p and k_i , the pi controller coefficients, directly. q-axis is considered to improve the drive performance. The objective function of this problem is the motor efficiency. A coefficient of k_p and k_i in each cycle is specified that has the maximum objective function.

3.2. Particle swarm optimization algorithm (PSO)

Searching for the optimal state is one of the most basic principles of the world around us [17]. PSO is an innovative optimization technique that was presented by Dr. Eberhart and Dr. Kennedy in 1995, and was inspired by the social behavior of birds and/or fish groups [18]. Unlike GA, PSO does not possess evolutionary operators like Crossover and mutation. In PSO the potential solutions are called particles that fly in the problem space [19].

In recent years, PSO has been used successfully in many researching and applied areas and has presented better, faster and cheaper results in many problems, as compared to other methods. Another reason that makes PSO attractive is that there are no quantitative

parameters to be set. A version with small variables can be applied easily in a wide range of applications [20]. Since its first presentation, this algorithm has found a wide range of applications in various areas [21,48]. The random population is called particle, which is estimated by a position and speed. The PSO speed and position update equation is given as:

$$v_i(k + 1) = wv_i(k) + c_1r_1(pb_{est_i}(k) - x_i(k)) + c_2r_2(gbest(k) - x_i(k)) \tag{11}$$

$$x_i(k + 1) = x_i(k) + v_i(k + 1) \tag{12}$$

Where, $v_i(k)$: the k th speed from the i th particle
 $x_i(k)$: the k th position from the i th particle
 k : the number of the algorithm iterations in $1 \leq k \leq n$
 i : the number of particles in the algorithm in $1 \leq i \leq N$
 $pb_{est_i}(k)$: the best place obtained by i particle
 $gbest(k)$: the best place found by the population.

C1 and C2 are the convergence coefficients, where C1 regulates the best place for every particle locally or spatially, and C2 find the best global place. C1 and C2 are in (0, 2) interval. r_1 and r_2 are in (0, 1) interval; they are selected randomly in PSO algorithm. w is the inertia weigh coefficient, considered as equal to 1 in most problems. The recent researches show that when w is between 0.9 and 1.4, it will have a faster convergence, while a larger coefficient would show a result of global search and a smaller coefficient would show a local search [22]-[23].

In [22] a new technique is presented that can increase efficiency and decrease losses in an induction motor according to PSO algorithm. In this reference, the maximizing efficiency strategy is applied to control the induction motor speed. The suggested technique of this research is based on flux level regulation with a certain load torque and speed. The block diagram of the PSO optimization process is shown in Figure 10.

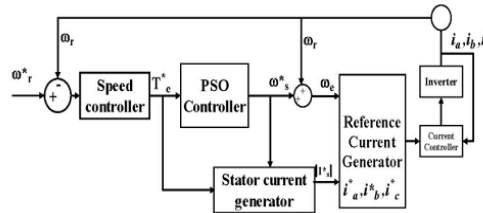

Figure 10. The model block diagram [22]

In the control process, PSO algorithm will receive the speed-related load torque and the calculated objective function (efficiency equation), PSO, obtains the slide frequency in the maximum efficiency. Figure 11 shows the ratio of efficiency percentage to torque and speed in modes of volt/hertz, FOC and PSO strategies.

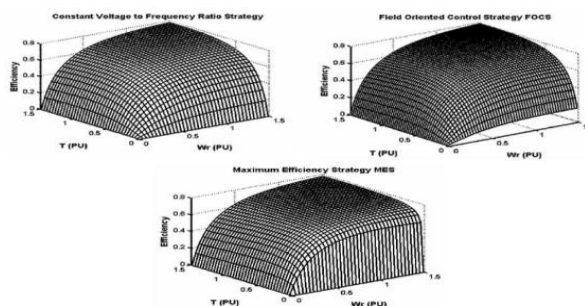

Figure 11. Efficiency to torque and speed ratio

In [23], the efficiency optimization is done with the help of PSO algorithm and Fuzzy Logic. The Fuzzy Precompensated Proportional-Integral (FPPI) is used to improve the motor dynamic performance during the motor control. In this reference, the motor flux level (i_{ds}^*) is optimized by PSO, and i_{qs} current is regulated by Fuzzy-PI Controller. The block diagram of the system proposed by this study is shown in Figure 12.

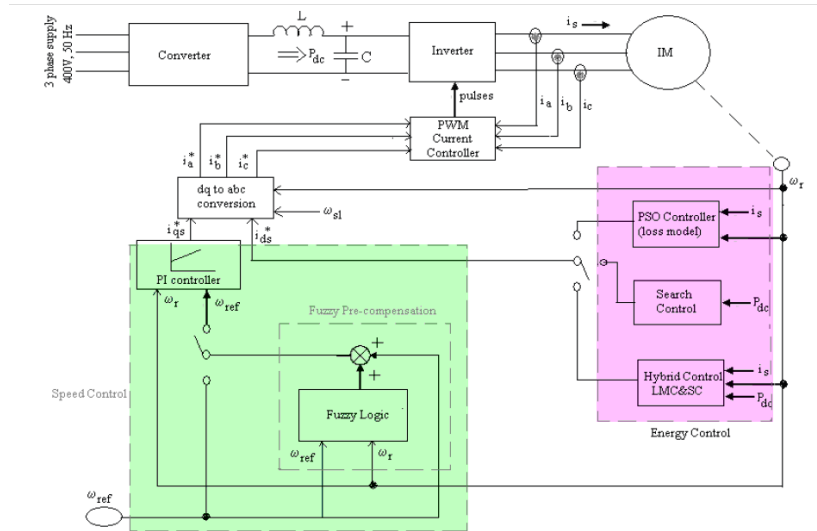

Figure 12. The model block diagram

According to the following relation, PSO algorithm searches for the optimal flux with least losses.

$$\text{Minimize } P_{loss}(Te, \omega_r, \varphi_m) \tag{13}$$

3.3. Fuzzy Systems

Recently, Fuzzy Logic as emerged as an attractive field in control researches. The most important principle in fuzzy logic is the structure of fuzzy controllers that employ the linguistic knowledge of the experts. As it can be observed in Figure 13, A fuzzy controller is consisted of 4 parts, two of which do the conversion action (Fuzzifier and Defuzzifier blocks).

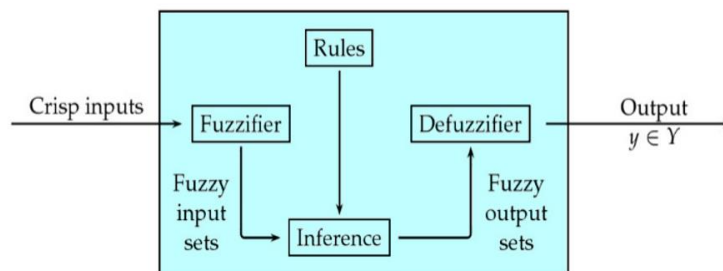

Figure 13. The block diagram of a control system with a fuzzy controller

When a classic controller (PI or PID) is used, the controller input is the error signal. For example, in a PI speed controller, the input is speed error, which is in fact the difference between the desirable speed and the actual speed.

$$E(K) = \omega_{ref}(k) - \omega_r(K) \quad (14)$$

But when a Fuzzy Logic controller is used, the controller would have more than one input. In most cases, the controller will have two inputs; the error input (E) and the change error (CE):

$$CE(K) = E(k) - E(K-1) \quad (15)$$

The Fuzzy Control used in the drives has two inputs: speed error and change error. Although, there can also be fuzzy controllers with more inputs. Given the ever-growing nature of machines and motors with different working conditions, and different characteristics appropriate for certain tasks, the controlling systems of these machines and motors should provide a high resistance against variation in system parameters and Motor characteristics, in order to be able to work efficiently in different conditions. Fuzzy logic is a good solution. In this logic, continuous variables are used instead of discrete ones and the answer is obtained without solving any mathematical problem. This Logic is used in constructing Fuzzy Controllers, which are completely robust against the above-mentioned variations [24]-[25].

Fuzzy Logic is used to Minimize Losses and maximize Efficiency in Induction Motors in two separate ways: using Fuzzy System in controlling d-axis (flux level control), and using Fuzzy System in controlling q-axis (speed control). The full block diagram for a fuzzy system (FLC) in controlling problems is shown in Figure 14.

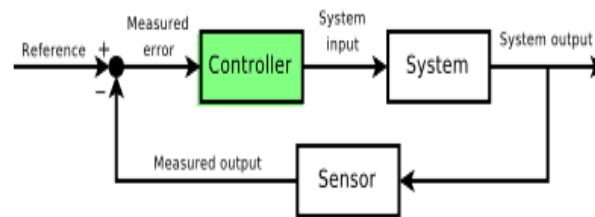

Figure 14. A fuzzy system general block diagram

The fuzzy system structure is appropriate for substituting P, PD, PI, and PID controller. References [16, 26-31] have used Fuzzy Logic in controlling the motor flux level in order to Minimize the Induction Motor Losses. The Fuzzy Logic Structure used in these references is presented in Figure 15.

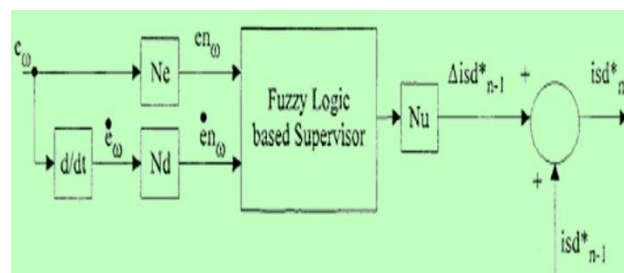

Figure 15. The Fuzzy System structure

As it can be seen in Figure 15, the structure of this fuzzy control is used in d-axis. In references [32]-[35] a Fuzzy Logic is used to speed control, i.e. q-axis or T_e torque control, in order to maximize the motor efficiency. As it is observed, the fuzzy inputs are speed error and speed variation derivative, and the reference torque is estimated at the system output.

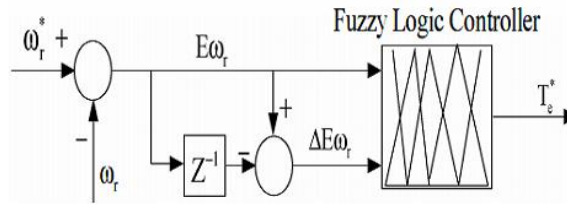

Figure 16. Fuzzy structure in [32]-[35]

The results have shown that using fuzzy logic in q-axis, known as speed control, provide a far better performance than a d-axis fuzzy controller. Another structure for a Fuzzy Logic system is to use it in order to determine the optimal coefficients of k_p and k_i in fuzzy speed control [36]. In fact, in this reference the disadvantages of PI controller are solved by the by the fuzzy system. As such, this method is used online, so it can provide some advantages such as stability certainty, flexible speed response, reduced speed waveform overshoot, lower permanent state error, and high performance. Figure 17 shows the system structure used in this reference.

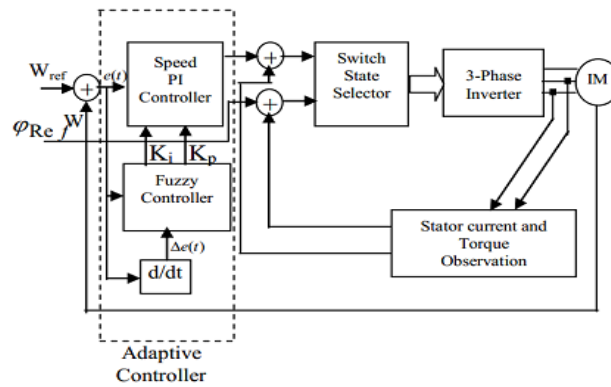

Figure 17. The structure of Fuzzy System in [36]

In [37], the fuzzy technique is used to control the current in q- and d-axis. These variables are used to calculate the rotor electromagnetic torque and flux in order to minimize the motor total losses. In this reference, the Fuzzy Logic is used to minimize the losses and control the motor speed. The block diagram in Figure 18 shows this control system.

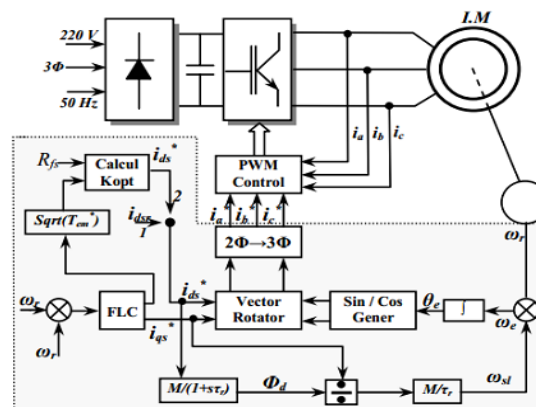

Figure 18. The model proposed by [37]

As it can be seen in Figure 18, i_{ds} reference current is also calculated using the fuzzy system. The T_{em}^* is calculated from Fuzzy output, and is given to K_{opt} calculator block, along with an appropriate R_{fs} for the motor speed. The d-axis flux is calculated as follows:

$$(\psi_{dr}^*)_s = k_{opt} \cdot \sqrt{|T_{em}^*|} \frac{d P_{loss}}{d \psi_{dr}} = 0 \tag{16}$$

$$k_{opt} = \sqrt{\frac{1}{p \cdot (1 - \sigma) \cdot L_s} \sqrt{\frac{R_s + \frac{R_r}{(1 + \sigma_r)^2} + \frac{\sigma_r \cdot R_{fs}}{(1 + \sigma_r)}}{R_s + R_{fs}}}}$$

The obtained results from this method also show a relatively better performance. These results are shown in Figure 19. As it can be observed, Losses in this way, has achieved less.

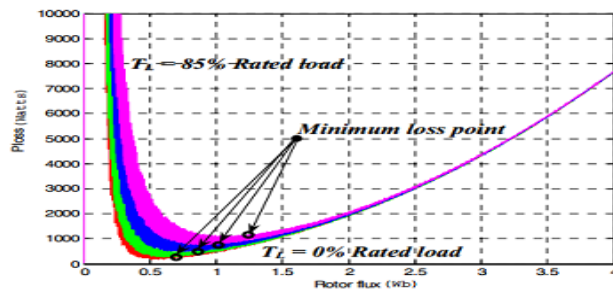

Figure 19. Losses to flux ratio of the rotor [37]

In [38], both Loss Minimization structures, i.e. LMC and SC, are considered by Fuzzy Logic. Figure 20 shows the structure presented by [38]. The core of this method can be seen in Figure 21.

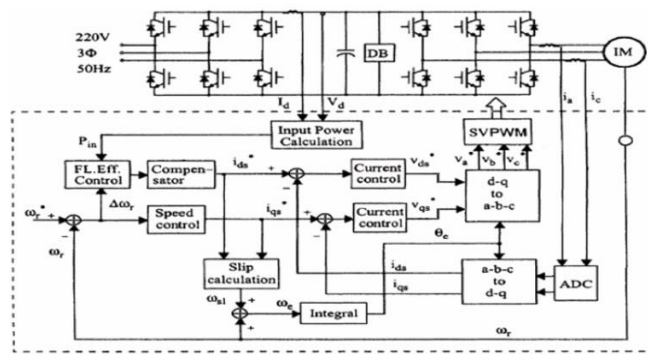

Figure 20. The motor controlling model using Fuzzy method with LMC and SC approaches [38]

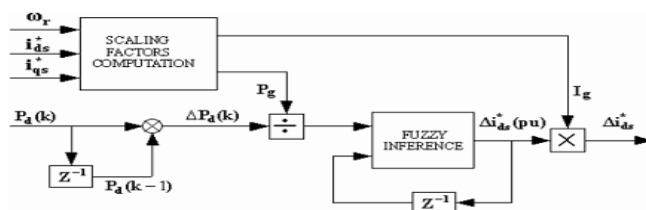

Figure 21. The Model proposed by [38]

One of the Fuzzy inputs in Dc power ($\Delta p_d(k)$), and the other one is Flux Current $\Delta i_{ds}(k-1)$. The new flux current $\Delta i_{ds}(k)$ is calculated according to these inputs. The amount of i_{ds}^* , p_d power and T_e torque, as well as the Motor Speed, are presented in Figure 22. As it can be observed, the input power in a constant torque has reduced significantly.

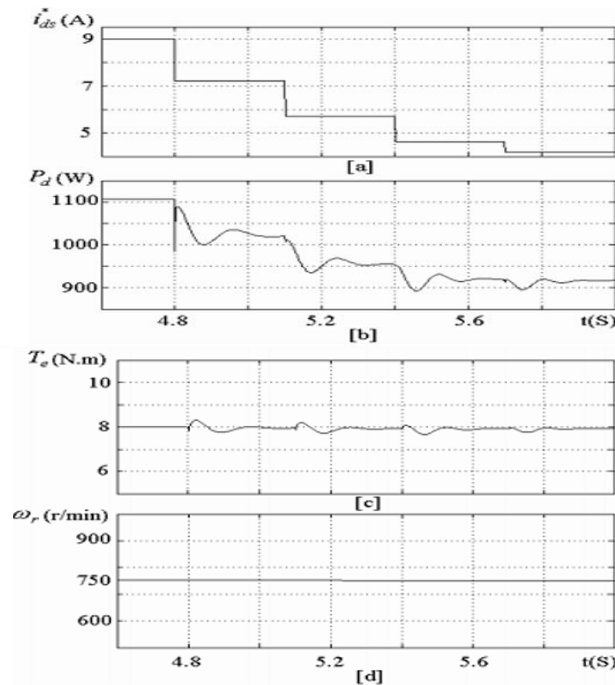

Figure 22. The optimal results from [38]

Reference [39] has utilized the Fuzzy-genetic method in order to improve a 5-hp induction Motor Efficiency. d-axis is controlled using the Genetic Algorithm and q-axis is controlled by the Fuzzy Logic. The Block diagram of the proposed system is presented in Figure 23.

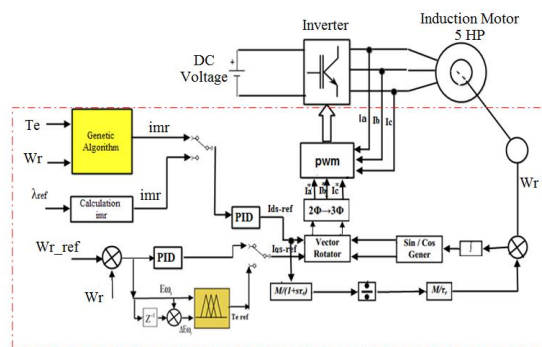

Figure 23. The model block diagram proposed by [39]

The Genetic Algorithm used in [39] is similar to Figure 5 and the Fuzzy system is similar to Figure 16. Also, three methods, including Field Orientation Control (FOC), Genetic Algorithm and Fuzzy-genetic, are compared in this reference, the results of which are presented in Figure 24. As it can be seen from the results, the Fuzzy-Genetic structure provides a better performance in different working conditions, even in low-load conditions. The motor used in this

reference is a 5-hp Motor, which is smaller than the motor used in [11], yet it provide 92% Efficiency.

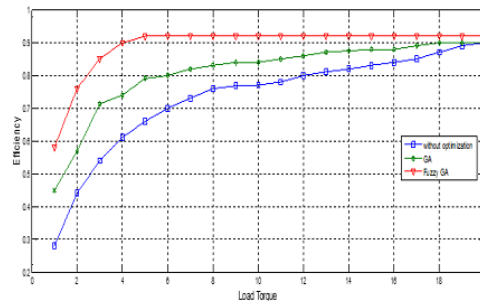

Figure 24. Comparing the three methods: FOC, GA, and FG [39]

3.4. The Artificial Neural Networks

Studying the Artificial Neural Networks (ANNs) is largely inspired by natural learner systems, where a complex set of interconnected neurons are involved in learning. It is thought that human brain is composed of 10^{11} neurons, each of which connected to about 104 other neurons. Nevertheless, man can recognize a human’s picture in 0.1 second. This extraordinary power should be a result of a distributed parallel processing in many neurons. ANN is a practical method for learning various Functions such as functions with real values, Functions with discrete values and Functions with vector values. ANN Learning is robust against learning data errors and these networks have been applied successfully in problems such as Speech Recognition, Picture Recognition, and Robot Learning. In this section, we first point out to the investigation of Induction motor speed control, controlled using voltage and frequency establishment, speed control by introducing resistance into rotor circuit etc.

Then, based on the ANN ability in approximating and controlling non-linear functions, and given the fact that an Induction Motor has a nonlinear structure, a Neural Network Model is constructed for the Induction Motor. In order to construct this model, the Motor voltage and current are considered as Inputs, and the Motor torque and speed are considered as the outputs, and ANN will be instructed according to some input-output data. The obtained model can provide a good approximation in comparison to the actual values.

In [40]-[47], ANNs are proposed to improve Induction Motor Drive Efficiency. The proposed structure by these references is the machine flux level. In fact the ANN model is used to predict the optimal flux level. References [40]-[44] have used a multilayered ANN with two inputs and one output. The two inputs are load torque and motor speed, and the output is an estimation of the flux level Ψ_r or i_{ds} . The motor block diagram is illustrated in Figure 25. The i_{ds} current is estimated for each torque and speed applied to the ANN. Structure of neural network is showed in Figure 26. as can be seen, network has 2 input and 1 output.

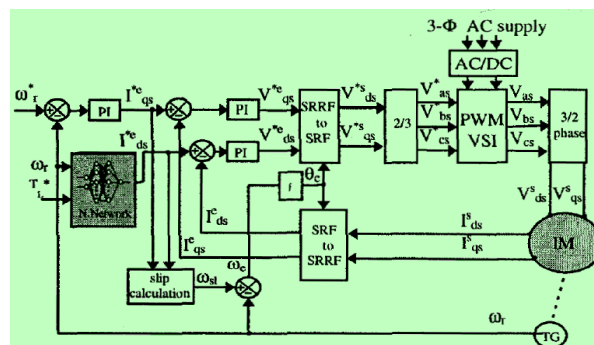

Figure 25. The proposed system model with i_{ds} -axis current control [40,44]

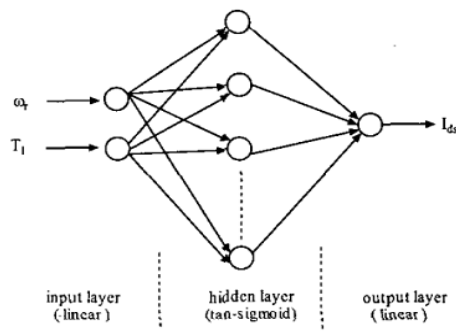

Figure 26. The ANN structure if [40,44]

References [45]-[46] have used an ANN with 4 inputs and one output. The four inputs are speed, torque, resistance difference ΔR_r and inductance differences ΔL_m , and an optimal flux Ψ_r is estimated at the output. The suggested structure of these two references is presented in Figure 27. The ANN structure used in these references is illustrated in Figure 28.

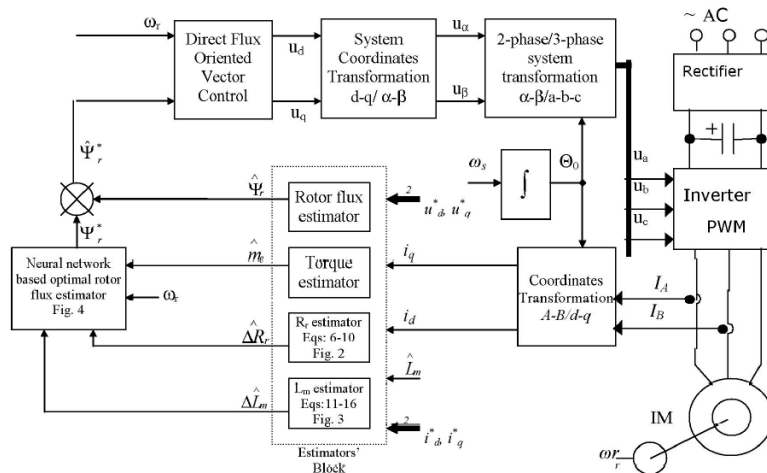

Figure 27. The motor drive structure with a 4-input, single-output ANN

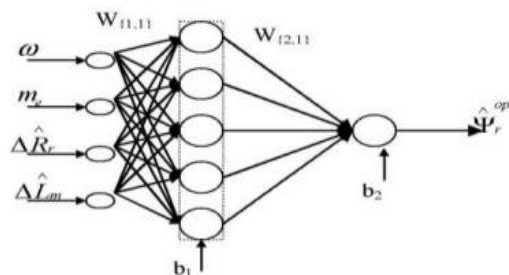

Figure 28. The proposed ANN structure in [45-46]

In [47], a combination of PSO and ANN is used to estimate d-axis flux. In this approach, the instructed ANN with PSO receives speed and load torque values and then applies the slip frequency in the optimal objective function conditions (best fitness) to the motor. In this reference, the objective function is employed with equation (17), known as weighted objective function. This

Function is a combination of three important Factors in induction motors; Efficiency, Stator Reverse Current, and Power Factor. This Objective Function is depended upon α_1 , α_2 and α_3 coefficients.

$$\text{weighted cost function} = \alpha_1(\eta) + \alpha_2\left(\frac{I}{I_s}\right) + \alpha_3(PF) \quad (17)$$

$$\text{where: } \alpha_1 + \alpha_2 + \alpha_3 = 1$$

Where, α_1 , α_2 and α_3 are Efficiency Weighted Coefficient, Stator Reverse Current Coefficient, and Motor Power Factor Coefficient, respectively. These coefficients vary according to the Objective Function characteristics. For example, if the least current of I_s is required, α_2 increases. Other modes are listed here:

- $\alpha_1 = 1$, $\alpha_2 = 0$ and $\alpha_3 = 0$, Maximize η
- $\alpha_1 = 0$, $\alpha_2 = 1$ and $\alpha_3 = 0$, Maximize I_s
- $\alpha_1 = 0$, $\alpha_2 = 0$ and $\alpha_3 = 1$, Maximize PF
- α_1, α_2 and α_3 are adjusted using PSO to Maximize the weighted cost function

These weighted coefficients are dependent on T_e and W_r conditions. The proposed system of this reference is illustrated in Figure 29, which is based on loss control model.

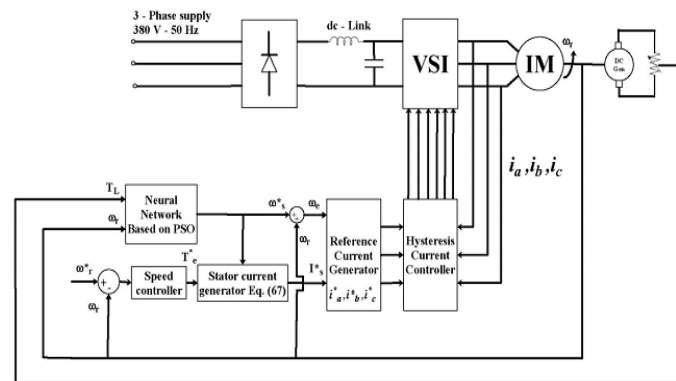

Figure 29. The block diagram for PSO and ANN combined model based on loss control model in [47]

4. Discussion on the Performances of the Methods

In previous sections, the implementation of each efficiency optimization method was presented. In this section, a comparison among the methods and their advantages and disadvantages are provided. One important issue in exploiting these controllers is their response time. In some processes the load variation period or the reference speed is high and the controller should refind the new optimal working area in the new conditions repeatedly. In such cases, the load variation period should be longer than the process stability in one working condition, so that the system would be able to save the power consumption efficiently. To present the advantages and disadvantages of each method, we divide them into classic and intelligent methods. The classic methods are discussed in section A and the intelligent ones are provided in section B.

4.1. The classic methods: a performance comparison

Since in most studies the LMC and SC methods are used, the discussion is focused on the performances of these two methods. LMC method is a fast method, because in this method the loss model is already saved in the motor controller and is calculated quickly upon the recognition of the working conditions of the motor, in which it should reach the optimal point.

The search controller (SC) method is slower than the prior method. It is due to the fact that in this method the losses feedbacks in each stage are taken and compared to the previous ones. Each time the controller changes the flux, the motor speed would change, so the controller should delay the operation till the motor speed reaches and is stabilized in the reference speed.

This prolongs the total time needed for the optimization process. Another important issue in designing and constructing controllers is the complexity of loss models and their final costs. Although the LMC method involves a heavy mathematical computation, it can be implemented using simple and relatively cheap methods. As such, this method does not need any speed feedback and can be employed in open-loop systems, which can help to simplify the controller. It can be said that, in power improvement and efficiency optimization problems, both of these methods minimize the power losses to a similar level. In SC method does need a speed feedback, so this method is a little more complex than LMC method. Instead it has the advantages of loop speed control, especially given the fact that they supply the motor in reduced flux under sup-nominal loads. In this case, the sudden load supply leads to a huge speed drop in the motor. The extent of this drop in a closed-loop control system is far lesser than in an open-loop system. Generally, a closed-loop system is employed in systems that require an accurate speed control. In such systems, where the measuring instruments and speed comparison with a reference value are existed, it is easier to use search controller method. It also should be noted that, the implementation of each controlling method depends on the available knowledge of the motor parameters. The LMC method is measured accurately according to the motor equivalent circuit, which is then introduced into the controller program. In addition, this controller should be investigated and programmed separately for each motor, which can further increase the designing costs. Additionally, sometimes these parameters and their measurements are not available or measurable for some motors used in production lines.

In SC method, there no need to any information regarding the motor parameters, thus once such a controller is designed it can be used for other motors, too. This is one of the great advantages of this method, so that such a controller can be redesigned and used for in any system, regardless of voltage, power and motor type, and without any information about the motor parameters. It is noteworthy that, regarding SC method, we are always sure that the efficiency in the operational point is set close the optimal operational point, because the Algorithm is designed in such a way that samples the loss amount and compares them in order to be able to move toward the area with lesser losses. The main defect of this method is the measuring accuracy and the noise existed in the measure loss (or the input power), which may lead to an inaccurate optimal operational point.

4.2. The intelligent methods: a performance comparison

In this paper, using intelligent systems is preferred to classic methods because of their simplicity, reliability, nonlinearity, etc. Also, the results of using each intelligent method, reported in several studies, provided a higher efficiency in comparison to the classic methods. In low-load conditions, the loss minimization and efficiency improvement procedure in induction motors with lower power is very sensitive than motors with high powers. As it was observed in the loss minimization methods, that basically two axis, q and d, are considered in order to improve the motor performance: d-axis as the flux level controller and q-axis as the speed or torque controller.

The obtained results show that, using GA and PSO for d-axis optimization provides a better performance and can lead to an efficiency up to about 60%. As such, the results of most papers written on fuzzy systems, show that using this method in controlling q-axis (speed control) plays an important role in efficiency improvement. Generally, it can be said that using GA and PSO in optimizing flux level or i_{sd} and fuzzy system in controlling q-axis proves a far better result in minimizing the motor losses.

5. The Conclusions and Further Suggestions

In this paper, classic and intelligent methods were investigated. In each one of them, different modes of methods were analyzed. In the classic category 3 methods, including LMC, flux control as a function of torque and SC, were investigated, of which LMC and SC provided a relatively better result in controlling flux level. Then, in order to improve the controller performance, some intelligent methods were considered, such as GA, PSO algorithm and fuzzy logic and ANNs. it was observed that using intelligent methods can lead to a reduced loss, reduced motor speed ripple, reduced flux and torque ripple, which can ultimately lead to a higher efficiency for the motor. Also, a large number of papers have used combined methods, Fuzzy-Genetic, Fuzzy-PSO,

Genetic-ANN, Fuzzy, ANN, etc., which could have minimize the motor losses with an efficiency of more than 90% in different loading conditions, even in low-load conditions.

6. Suggestions

There are still ways to complement the future researches in the existing methods investigated in this paper, it is suggested that: Firstly, ANNs are not employed to estimate resistance differences R_d and R_q in motor, which can be used in [11-16] in genetic optimization process. Secondly, in [39] the genetic-fuzzy method is employed separately to control q- and d-axes. Applying the fuzzy-PSO method is not practiced, which can lead to a relatively better performance. Thirdly, in speed control structure the type I fuzzy is used, which can introduce some uncertainty in selecting T_e reference. If type II fuzzy is used, the speed ripple and torque would decrease significantly, and this decrease can lead to efficiency improvement.

References

- [1] John McCarthy. Recursive functions of symbolic expressions and their computation by machine, Part I. *Communications of the ACM*. 1960; 3(4):184-195.
- [2] Chandan Chakraborty, Senior Member, Yoichi Hori, Senior Member, IEEE. Fast Efficiency Optimization Techniques for the Indirect Vector-Controlled Induction Motor Drives. *IEEE Transactions on Industry Applications*. 2003; 39(4): 1070 - 1076.
- [3] Shahriyar Kaboli, Mohammad Reza Zolghadri. A Fast Flux Search Controller for DTC-Based Induction Motor Drives. *IEEE Transaction on Industry Electronics*. 2007; 54(5).
- [4] Shahriyar Kaboli, Mohammad Reza Zolghadri. *Online Optimal Flux Controller for DTC Based Induction Motor Drives*. The 30th Annual Conference of the IEEE Industrial Electronics Society, Busan, Korea. 2004.
- [5] Fidel Fernandez Bernal, Aurelio Garcia Cerrada. Model-Based Loss Minimization for DC and AC Vector-Controlled Motors Including Core Saturation. *IEEE Transaction on Industry application*. 2000; 36(3).
- [6] M Nasir Uddin, Nam sang Woo. Adaptive Backstepping Based Online Loss Minimization Control of an IM Drive. *Power Engineering Society General Meeting, IEEE*. 2007.
- [7] Isao Takahashi, Toshihiko Noguchi. A New Quick-Response and High-Efficiency Control Strategy of an Induction Motor. *IEEE Transaction on Industry application*. 1986; IA-22(5).
- [8] M Nasir Uddin, Nam Sang Woo. New Online Loss-Minimization-Based Control of an Induction Motor Drive. *IEEE Transaction on Power electronics*. 2008; 23(2).
- [9] David E. Goldberg. *Genetic Algorithms in Search, Optimization and Machine Learning Reading*. MA: Addison-Wesley, USA. 1989.
- [10] Renders JM. *Genetic Algorithms and Neural Network*. Hermes, Paris. 1995.
- [11] Waheedabeevi, Sukesh Kumar. *loss minimization of vector controlled induction motor drive using genetic algorithm*. Trans IEEE: International Conference on Green Technologies (ICGT). 2012: 251-257.
- [12] Eric Pokier, Mohsen Ghribi, AzeddineKaddouri. *Loss Minimization Control of Induction Motor Drives Based on Genetic Algorithms*. IEEE International Electric Machines and Drives Conference, IEMDC. 2001: 475-478.
- [13] Rouabah Z, Zidani F, Abdelhadi B. *Efficiency optimization of induction motor drive using genetic algorithms*. 4th IET Conference on IEEE International Electric Machines and Drives Conference. 2008: 204-208.
- [14] Lin Feng, Zheng Hongtao, Yang Qiwen. *Sensorless vector control of induction motors based on online GA tuning PI controllers*. Fifth International Conference on Power Electronics and Drive Systems. IEEE, Singapore. 2003; 1: 222-5.
- [15] Jung Sik Choi, Jae Sub Ko, Ki Tae Park. *High Performance Control of Induction Motor using GA*. International Conference on Control, Automation and Systems, in COEX, Seoul, Korea. 2007.
- [16] Z Rouabah, F Zidani, B Abdelhadi. Efficiency optimization of induction motor drive using fuzzy logic and genetic algorithms. *ISIE*. 2008: 737-742.
- [17] T Weise. *Global Optimization Algorithms-Theory and Application*. Self-Published. second edition, 2009. Online available at <http://www.it-weise.de/>.
- [18] Kennedy J, Eberhart RC. *Particle Swarm Optimization*. Proceedings of IEEE International Conference on Neural Networks, Piscataway, NJ. 1995: 1942-1948.
- [19] Michael G. Hinchey, Roy Sterritt. *Swarms and Swarm Intelligence*. IEEE Computer Society. 2007; 40(4): 111-115.
- [20] J Kennedy, RC Eberhart. *Particle swarm optimization*. Proceedings of IEEE International Conference on Neural Networks. 1999; 4: 1942-1948.

- [21] Chatterjee, K Pulasinghe, K Watanabe etc. A Particle-Swarm-Optimized Fuzzy–Neural Network for Voice-Controlled Robot Systems. *IEEE Trans. On Industrial Electronics*. 2005; 52: 1478-1489.
- [22] Radwin HA Hamid, Amr MA Amin, Refaat S Ahmed, Adel AA El-Gammal. *New technique for maximum efficiency and minimum operating cost of induction motors based on particle swarm optimization*. 32nd Annual Conference on IEEE Industrial Electronics. 2006: 1029-1034.
- [23] TR Chelliah, JG Yadav. *Optimal Energy Control of Induction Motor by Hybridization of Loss Model Controller Based on Particle Swarm Optimization and Search Controller*. World Congress on Nature & Biologically Inspired Computing. 2009: 1178–1183.
- [24] G Sousa. Application of Fuzzy Logic for Performance Enhancement of Drives. Phd Dissertation, Univ. of Tennessee, Knoxville. 1993.
- [25] Sergaki Eleftheria. Fuzzy Logic Search Efficiency Controller For Electrical Drives. Patent No. 1006612, INT.CL HO2P 21/08.
- [26] Eleftheria S Sergaki. *Motor Flux Minimization Controller based on Fuzzy Logic Control for DTC AC Drives*. International Conference on Electrical Machines-ICEM, Rome. 2010
- [27] Moreno Eguilaz, Miguel Cipolla, Juan Peracaula, Paul.j da Costa Branco. *Induction Motor Optimum Flux Search Algorithms with Transient State Loss Minimization using a Fuzzy Logic based Supervisor*. 28th Annual IEEE Power Electronics Specialists Conference. 1997; 2: 1302-1308.
- [28] Ramesh L, P Chowdhury S, Chowdhury S. *Efficiency Optimization of Induction Motor Using a Fuzzy Logic Based Optimum Flux Search Controller*. International Conference on Power Electronics, Drives and Energy Systems, PEDES. 2006.
- [29] Venkatachalam M, Thangavel S. *Fuzzy Logic Based Performance Improvement of Induction Motor*. 2012 IEEE International Conference on Engineering Education: Innovative Practices and Future Trends (AICERA). 2012: 1-7.
- [30] Juan Moreno, Miguel Cipolla, Juan Peracaula, Paul J. da Costa Branco. *Fuzzy logic based Improvements in Efficiency Optimization of Induction Motor Drives*. Proceedings of the Sixth IEEE International Conference on Fuzzy Systems. 1997; 1: 219 - 224.
- [31] Yanamshetti Raju, Bharatkar SS, Chatterjee, AK Ganguli. *A Hybrid Fuzzy Based Loss Minimization Technique for fast Efficiency Optimization for Variable Speed Induction Machine*. 6th International Conference on Electrical Engineering/Electronics, Computer, Telecommunications and Information Technology, ECTI-CON. 2009; 1: 318–321.
- [32] Bahram Kimiaghali, Meisam Rahmani, Hassan Halleh. *Speed & Torque Vector Control of Induction Motors with Fuzzy Logic Controller*. International Conference on Control, Automation and Systems, 2008 in COEX, Seoul, Korea. 2008.
- [33] Radwan' TS. *Perfect Speed Tracking of Direct Torque Controlled-Induction Motor Drive Using Fuzzy Logic*. International Conference on Power Electronics and Drives Systems (PEDS). 2005; 1: 38–43.
- [34] Te j avathu Ramesh, Anup Kumar Pandl, Y Suresh. *Direct Flux and Torque Control of Induction Motor Drive for Speed Regulator using PI and Fuzzy Logic Controllers*. International Conference on Advances In Engineering, Science And Management (ICAESM). 2012: 288–295.
- [35] Gilberto CD Sousa, Bimal K Bose, John G Cleland. *Fuzzy Logic Based On-Line Efficiency Optimization Control of an Indirect Vector-Controlled Induction Motor Drive*. *IEEE Transactions on Industrial Electronics*. 1995; 42(2).
- [36] Abdalla, Turki Y, Hairik, Haroutian Antranik, Dakhil, Adel M. *Direct Torque Control System for a Three Phase Induction Motor with Fuzzy Logic Based Speed Controller*. 1st International Conference on Energy, Power and Control (EPC-IQ). 2010: 131-138.
- [37] AH Haddoun, J Ghouili, R Abdessemed, K Srairi. *Efficiency-minimization loss based fuzzy logic control of induction machine*. Electrical and Computer Engineering, Canadian Conference. 2005: 774-777.
- [38] Zhang Liwei, Liu Jun, Wen Xuhui. *A new fuzzy logic based search control for efficiency optimization of induction motor drives*. The 7th International Power Engineering Conference (IPEC). 2005: 1-5.
- [39] Sadeghesari, Mohammad Baghernaghibi Sistani. *Efficiency Improvement of Induction Motor using Fuzzy-Genetic Algorithm*. 30th Power System Conference (PSC), 2015, IEEE. 2015.
- [40] Li Zhang, Hasan KM. *Neural Network Aided Energy Efficiency Control for a Field-Oriented Induction Machine Drive*. Ninth international Conference on Electrical Machines and Drives, Conference Publication. 1999; 468: 356–360.
- [41] Bogdan Prymak, Juan M Moreno-Eguilaz, Juan Peracaula. *Neural Network based Efficiency Optimization of an Induction Motor Drive with Vector Control*. 28th Annual Conference of IEEE Industrial Electronics Society. 2002; 3: 146-151.
- [42] Abdin ES, Ghoneem GA, Diab HMM, Deraz SA. *Efficiency optimization of a vector controlled induction motor drive using an artificial neural network*. The 29th Annual Conference of the IEEE Industrial Electronics Society. 2003; 3: 2543-2548.
- [43] Zhanyou Wang, Shunyi Xie, Yinghua Yang. *A Radial Basis Function Neural Network Based Efficiency Optimization Controller for Induction Motor with Vector Control*. 9th International Conference on Electronic Measurement & Instruments (ICEMI). 2009: 866-870.

- [44] Hasan KM, Li Zhang, Singh B. *Neural Network Control of Induction Motor Drives for Energy Efficiency and High Dynamic Performance*. 23rd International Conference on Industrial Electronics, Control and Instrumentation, IECON 97. 1997; 2: 488-493.
- [45] Mino Aguilar, Moreno Eguilaz JM, Prymak B, Peracaula J. *A Comparative Analysis of Two Neural-Network-Based Estimators for Efficiency Optimization of an Induction Motor Drive*. 10th IEEE International Power Electronics Congress. 2006: 1-6.
- [46] Mino Aguilar G., Moreno-Eguilaz JM, Prymak B, Peracaula J. *Neural Network Based Optimal Rotor Flux Estimator for Efficiency Optimization of an Induction Motor Drive*. IEEE International Symposium on Industrial Electronics. 2006; 3: 2528–2534.
- [47] Radwan HA Hamid, Amr MA Amin, Refaat S Ahmed, Adel AA El-Gammal. *Optimal Operation of Induction Motors Using Artificial Neural Network Based on Particle Swarm Optimization (PSO)*. IEEE International Conference on Industrial Technology, ICIT. 2006: 2408–2413.
- [48] Sadegh, Hesari, Mohammad Bagher Naghibi Sistani. *Efficiency improvement by timely controlling power factor in permanent magnet synchronous motor using PSO algorithm*. First International Congress on Technology, communication and knowledge (ICTCK), IEEE. 2014: 26-27.