

Development of Blumlein Line Generator and Reactor for Wastewater Treatment

Zainuddin Nawawi^{*1}, Muhammad Abu Bakar Sidik^{1,2}, Zolkafle Buntat²,
S. M. Zafar Iqbal², Hashem Ahmadi², Muhammadjavad Mobarra²

¹Department of Electrical Engineering, Faculty of Engineering, Universitas Sriwijaya,
Ogan Ilir, South Sumatera, Indonesia

²Institute of High Voltage and High Current (IVAT), Faculty of Electrical Engineering
Universiti Teknologi Malaysia, 81310 UTM Johor Bahru, Malaysia

Corresponding author, e-mail: nawawi_z@yahoo.com, abubakar@fke.utm.my

Abstrak

Ada beberapa metode dan teknik pengolahan air limbah yang telah diperkenalkan menggunakan proses biologi, kimia, dan fisik. Namun, ditemukan bahwa ada beberapa kekurangan dalam metode dan teknik yang tersedia saat ini. Misalnya, penerapan klorin dapat menyebabkan desinfeksi bakteri tetapi menghasilkan desinfeksi karsinogenik sekunder yang berbahaya. Dalam rangka memperoleh pemahaman yang lebih baik dalam proses pengolahan air limbah, dilakukan sebuah studi sistem pengolahan air limbah dan reaktor discharge hybrid untuk memperoleh corona fasa cair pada gas. Selain eksperimen laboratorium, dilakukan juga perancangan dan pengembangan rangkaian daya pulsa Blumlein dan modifikasi reaktor untuk pengolahan air limbah. Rangkaian daya pulsa Blumlein ini membangkitkan pulsa tegangan tinggi nanodetik. Reaktor discharge hybrid ini dapat menghasilkan pelepasan percikan pada fasa gas maupun cair. Analisis spektrum emisi pada terjadinya pelepasan ditemukan adanya berbagai bahan kimia seperti radikal OH. Selain itu, peningkatan drastis dalam hal kandungan oksigen dan tingkat konduktivitas sampel air limbah.

Kata kunci: Blumlein, hybrid discharge, pelepasan percikan, pengelolan air limbah, reaktor

Abstract

There are several wastewater treatment methods and techniques which have been introduced such as by using biological, chemical, and physical process. However, it is found that there are some shortcomings in the current available methods and techniques. For instance, the application of chlorine can cause bacterial disinfection but produce secondary harmful carcinogenic disinfection. In order to acquire a better understanding in wastewater treatment process, a study of wastewater treatment system and hybrid discharge reactor to acquire gas liquid phase corona like discharge is carried out. In addition to the laboratory experiment, designing and development of the Blumlein pulse power circuit and modification of reactor for wastewater treatment are accomplished as well. The Blumlein pulse power circuit generates nanosecond high voltage pulses. The Hybrid Discharge reactor can produce both spark discharge in gas phase and liquid phase (spark-spark discharge). Analysis of the emission spectrum of the occurring discharge found the existence of various chemicals such as OH radicals. In addition, a drastic improvement in terms of oxygen content and conductivity level of the wastewater sample is also observed.

Keywords: Blumlein, hybrid discharge, reactor, spark discharge, wastewater treatment

1. Introduction

A good quality of water is very essential for mankind. Therefore a standard of quality should be followed before the water is allowed to be consumed [1]. A lot of health problems surely emerge if contaminated waters are consumed as well as used by the people for daily activities [2-4]. In line with the increasing number of people in the world, the consumption of a good water quality also inclines [5-6]. On the other hand, the amount of wastewater production that come from dwellings and manufacturing continue to grow each year. The contaminants are also increasing in terms of varieties [7-9]. Now the treatments of waste waters-scratches of extra sludge, decomposition of rotten compounds, purification of microbes, efficacy and economic are being required.

Particular contaminants still exist when they are treated by using traditional wastewater treatment systems. The wastewater treatment could be categorized as organic, physical and biochemical process. The broadly used technique for bacteriological decontamination of water is chlorination. Chlorine as a decontamination can produce a secondary by-product that causes cancer [10].

Biological colours are used in numerous manufacturing such as fabrics, paper, plastic, leather, and toner. They characterize a significant foundation of ecological contamination. These mixtures are extremely solvable in water, they can be streamed over a long distance when they are discharged in torrents and rivers. Biological colours might harm to the living bacteria by discontinuing the re-oxygenation ability of water and obstructive sunshine. These cause a disturbance to the natural growing activities in the water. The traditional physical processes cannot be used to eliminate the colour contaminants efficiently. Since, the traditional physical processes are non-destructive method, the contaminants are only transferred to compact phase which causes subordinate contaminants [11-15].

Another wastewater treatment method is organic approaches. The organic approaches are the prominent technique for wastewater treatment as they are an inexpensive method for treating wastewaters from civic dwellings as well as particular industry. Yet, the organics schemes have an inability to efficiently eliminate some numerous modules of impurities including poisonous complexes-even though there are many developments in bio-organics. Moreover, these schemes require a vast facility [16-17].

A requirement of effective and efficient technique has been an interesting investigation of the application of high voltage electrical discharge in liquid decontamination. Currently, water treatment using ozone is being used as a new treatment technique, for the reason that ozone has strong oxidizing influence. Ozone is effective for decomposition of insistent biological complexes in water. Furthermore, it has a capacity for deodorization and purification. Nonetheless, this process takes some difficulties. In this system, ozone is produced by an ozonizer. Then the ozone is fed into the treatment chamber comprising wastewater by an air push [18-19]. However, the total of produced ozone cannot be used for water treatment as a part of the generated ozone is spoiled.

Water treatment by high voltage pulsed discharge technique could be a solution for the addressed problems [20]. With this technique the discharges are produced in water. In that way, OH radical, ozone and ultraviolet can be produced in water. Furthermore, the shock waves can be produced in water as well. Since OH radical has the tougher dissolving capability than ozone, the discharge of water can spoil biological mixtures in water more efficiently than the ozone treatment.

This paper addresses a study to improve a wastewater treatment system and the reactor to acquire gas-liquid phase reactor. The work focuses in two subsystems, viz.: pulse generator and reactor system.

2. Research Method

This work was carried out in the laboratory of the Institute of High Voltage and High Current (IVAT), Universiti Teknologi Malaysia. The works included the design and development of Blumlein line generator and Hybrid discharge reactor, as well as the experimental work.

2.1. Blumlein line Generator

Blumlein line generator is a high voltage generator made of numbers of transmission lines. Generally, Blumlein line is used in some applications such as in lasers, high power microwave generators, and x-ray generation. It is able to generate high voltage pulses of numerous hundreds kilovolt in nanosecond or microsecond. Basically Blumlein line generator contains of transmission lines (strip lines or coaxial cables) that are charged in parallel and discharged synchronously in series into the load. In this work the pulse is generated by stacking three Blumlein lines. Each of Blumlein line contains of two transmission lines connected in series with an energized line on the left and a reflexive line on the right as shown in Figure 1. The stacked Blumlein line generator is made up of six coaxial cables with the length of 10 m.

The reflexive lines are used for storing the charge voltage they could be substituted by capacitors. The load is fixed in 300 Ω and the input voltage is 10 kV. In the circuit the 300 Ω

load is very important to obtain the fruitful pulse waveform. Before the Blumlein line a resistor of $2.5 \text{ M}\Omega$ is placed to control the current flow in the circuit.

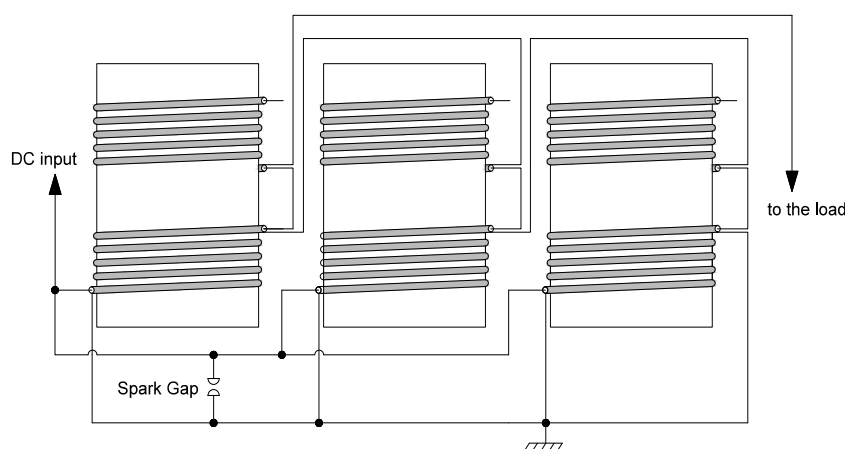

Figure 1. Three stages double Blumlein line.

2.2. Hybrid Discharge Reactor

A gas-liquid hybrid discharge (HD) reactor through ground electrode above water level and high voltage electrode immersed in water has been reported. HD reactor exploits together gas phase non-thermal plasma formed overhead the water and straight liquid phase corona-like discharge (spark-corona discharge, SCD).

Spark discharge in liquid has benefit to treat contaminant supplementary fully than corona discharge. The HD reactor has that ability to create equally spark discharge in gas phase and liquid phase (spark-spark discharge, SSD). HD reactor would produce additional energetic sorts, such as O_3 , H_2O_2 , O and OH by the concentrated spark discharge.

The underwater electrical discharge has been concerned broadly in water or wastewater treatment. Commonly, the underwater electrical discharges pledge both physical and chemical procedures for instance high electrical field, radiation ultraviolet, shockwave, bubble, and development of chemical reactive species (OH , H_2O_2 , O_2 , O_3 , etcetera). The biochemical active species produced by the electrical discharge could violence and degrade the biological contaminants confined in the water. Moreover, the biochemical energetic species is created in bulk water therefore an outer source has not been continuously essential.

The advanced permittivity ($\epsilon_r = 81$) and density (103 kg/m^3) of water in high electrical field-in order of megavolts per centimetre-has essential to start the electrical discharge. A pointed and half spherical electrode is normally used to produce the electrical discharges in water, since a localized high electrical field could be simply formed in the pointed electrode. As shown in Figure 2, a reactor consists of pointed and half spherical electrode has been developed. This reactor is equipped with O_2 inlet channel. In this reactor combine gas and liquid phase together for treating the wastewater.

3. Experimental Setup

The experimental arrangement is shown in Figure 3, and photograph of the experimental is shown in Figure 4. A stable HVDC power supply is required to feed the Blumlein line generator. The HV DC power supply output was controlled by a voltage regulator from the primary input of a HV transformer. The transformer ratio and working frequency are $220 \text{ V}/100 \text{ kV}$, $50/60 \text{ Hz}$.

The primary output of the transformer was connected to a rectifier unit which consists of a high voltage diode and protective resistor. A capacitor of 25000 pF was connected in parallel after the rectifier unit. The capacitor functioned as waveform smoothing. Then, to measure the HVDC output a voltage divider was utilised. The voltage divider is typical of resistance or normally named resistor divider. The rating value of the measuring resistor is $280 \text{ M}\Omega$, 0.5 mA , and 140 kV .

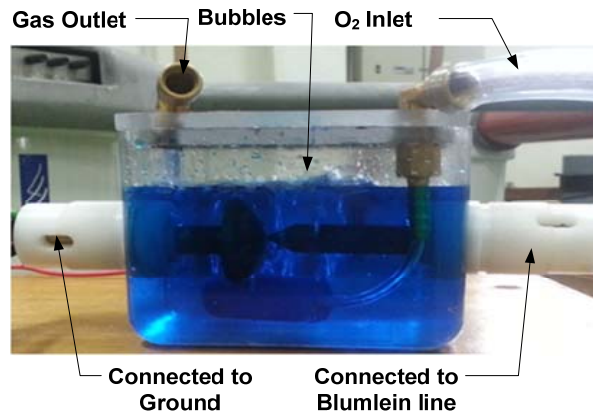

Figure 2. Hybrid discharge reactor

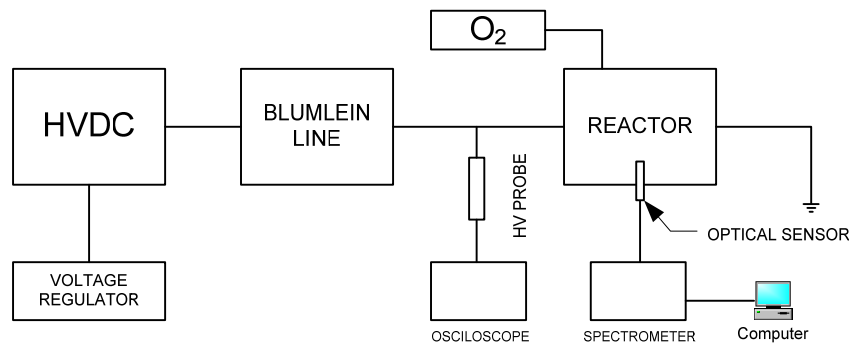

Figure 3. Schematic diagram of the experiment.

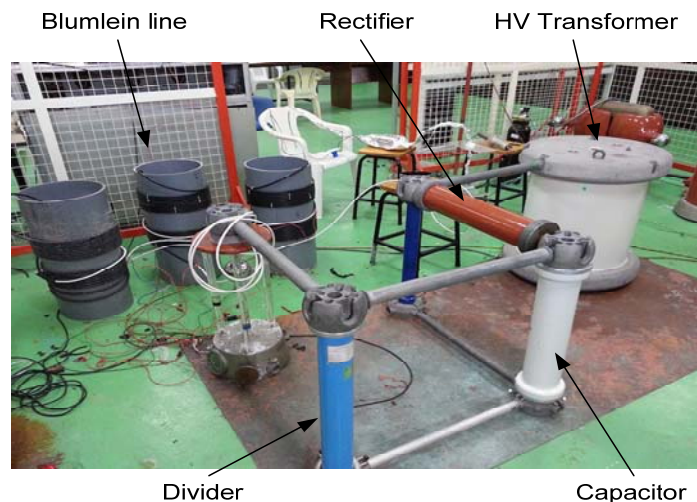

Figure 4. Photograph of the experimental arrangement to generate nanosecond pulses.

The secondary part of resistor divider is a low voltage divider for DC measurements, SEK DC, which incorporate the low voltage resistor and a 75Ω matching resistor. The SEK DC connected the HF-socket of the resistor divider and a Digital Measuring Instrument (DMI) 551 by means of a coaxial cable (MK BNC). In addition, to measure the output voltage from the Blumlein line generator an oscilloscope was attached through a high voltage probe.

In order to simulate the wastewater, Brilliant blue FCF was dissolved in water with a concentration of 20 mg/L. Brilliant blue FCF is a synthetic dye produced from petroleum. This experiment used O_2 with a pressure of 70 bars to produce small bubbles between the pointed and spherical electrodes. Therefore a gas-liquid phase discharge was acquired.

The light that is produced by an occurring discharge can provide much information in terms of the emitted wavelength. To analyse the light a device such as spectrometer-to break the light into spectral components-is needed. The developing spectral depends on the molecular structure.

Finally the quality of treated water was examined by using YSI 6600 V2 Data Sonde. It is a comprehensive water quality monitoring equipment which is available measurement conductivity, temperature, pH, dissolved oxygen, turbidity, chlorophyll, and blue-green algae and many more parameters.

4. Results and Discussions

Prior to the development of Blumlein line generator simulation study was carried out. Then, it was continued with the development process. Later on, when the work on the reactor was accomplished, the experiment was performed.

4.1. Nano second pulse discharge

In order to develop a Blumlein line which complies with the required output characteristic i.e. voltage and frequency, a simulation using the PSpice software has been accomplished. The simulation circuit is shown in Figure 5 and Figure 6 shows the simulation result.

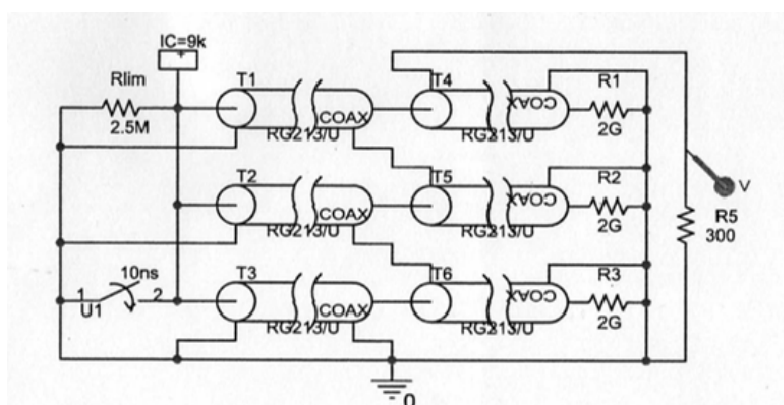

Figure 5. PSpice model of the three stages double Blumlein line generator.

As shown in the Figure 6, the maximum output voltage reaches about 30 kV and reduces sharply to 27 kV in very short time. As such, it could be said that the 30 kV is the simulation uncertainty result and 27 kV is the value which is considered as the true result. Thus, it can be stated that the output of the simulation circuit is three times of the charging voltage which is 9 kV. According to the coaxial cable specification, the highest voltage that can be applied to the cable is 10 kV. And the simulation result has shown that at 9 kV charging voltage the output voltage that may be reached is about 27 kV, thus the applied voltage to the developed Blumlein line generator was set to 9 kV. The result of the developed Blumlein line generator is shown in Figure 7.

In Figure 7 is shown that the maximum output voltage is less than 25 kV. There is a difference about 2 kV between the simulation and actual results. The actual result shows a reduction in terms of voltage output due to the some losses in the system which consists of several connections and cables. Even though, the obtained output voltage is sufficient to initiate discharges in the electrode gap of the reactor. Figure 8 shows a discharge occurs in the wastewater sample.

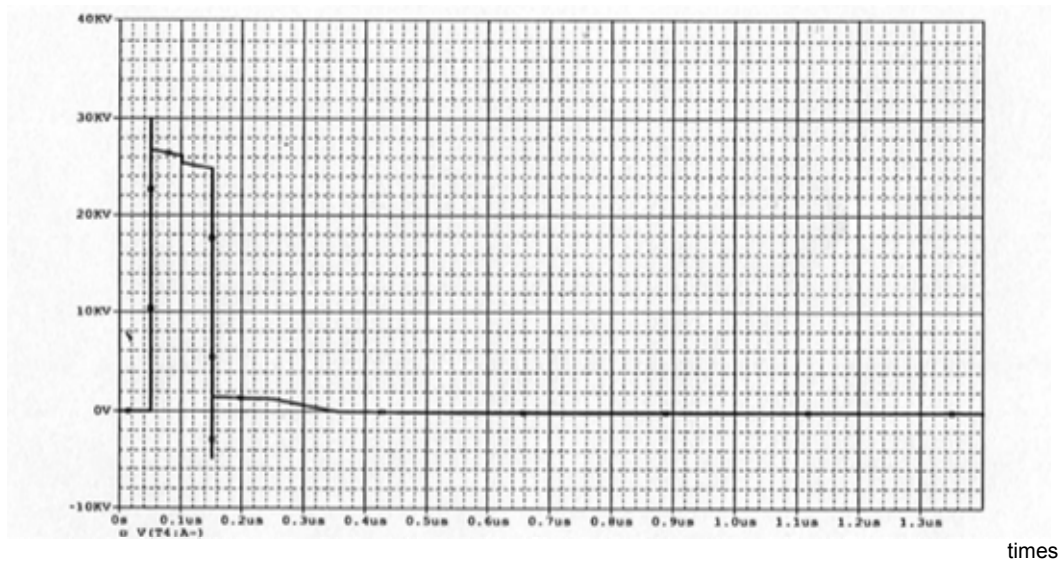

Figure 6. Simulation result of the Blumlein line.

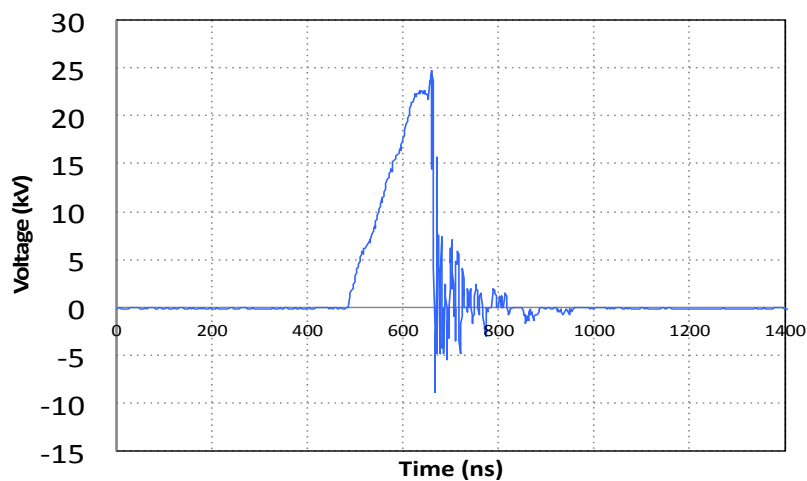

Figure 7. The output voltage of developed Blumlein line generator, the charging voltage is 9 KV.

4.2. Sample Test

Several parameters of the wastewater sample have been observed before and after the experiment. The main purpose of the experiment is to investigate the development of reactive species which are required for wastewater treatment. The sample was observed by using YSI 6600 V2 Data Sonde. In the observation was found that increases the water conductivity significantly as well as the oxygen concentration. These two components have important roles in producing ozone and easing discharge. The combination of the both components has been proven in wastewater treatment. Meanwhile, two other components: temperature and pH, have shown a trivial augmentation. Figure shows the observation results of the wastewater sample.

4.3. Wavelength Analysis

The positive and negative polarity voltages were applied to wastewater sample. An emission spectrum of 385-745 nm was obtained from the occurring discharge in the wastewater sample as shown in Figure 10.

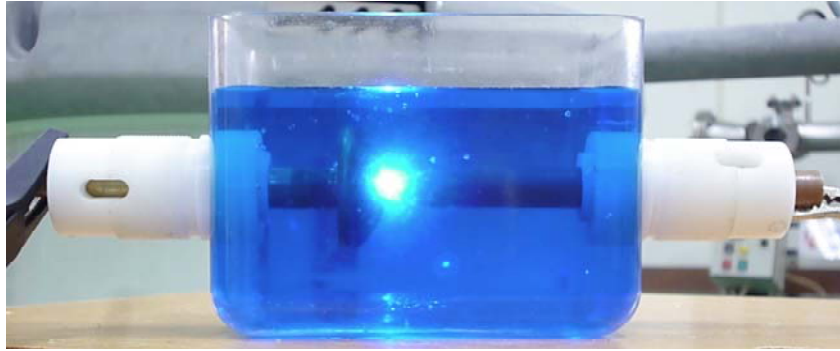

Figure 8. Discharge in wastewater sample.

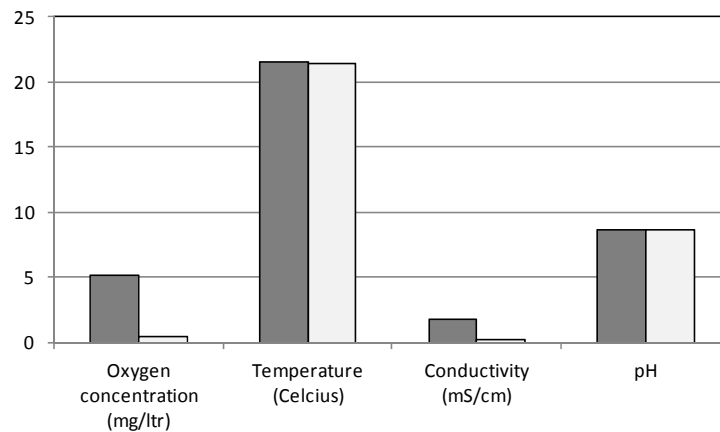

Figure 9. Wastewater sample observation results.

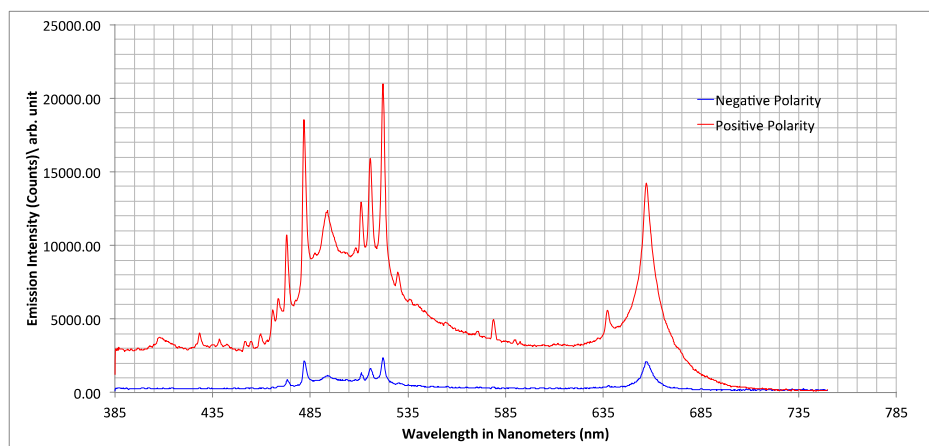

Figure 10. Emission spectrum of discharge in wastewater sample.

It is clear that during the discharge various chemicals had been produced. Four atomic emission lines i.e. 521.8, 515, 510.5 and 493.2 are triggered by the pointed electrode which is copper. Meanwhile, the presence of three atomic emission lines of zinc came from the grounded brass material. Other chemicals produced in the experiment are part of the Balmer series of emission lines from gaseous atomic hydrogen such as $H\beta$ and $H\gamma$. Hydroxyl radicals (OH)-a highly reactive species comes from decomposition of water molecules-is also produced as the occurring discharge. Further, Figure 10 shows the weakening of emission intensity when the

negative polarity was applied. Thus, the positive pulse discharge is a better polarity when it is applied to the wastewater.

5. Conclusion

In this century in line with the growth of birth rate the supply of good quality waters to the public has been being a major concern. Issues on the wastewater from industrial sectors have been made the problems become more complex. This paper presents an achievement of a research that carried out to develop a system to treat the wastewater by using a liquid-gas discharge method. The development of a double Blumlein line generator has been carried out and a good output voltage in term of magnitude and frequency has been obtained. A hybrid reactor has been developed as well. The testing results of the wastewater sample have been coming out with some good results. It is proved that the system has worked with satisfactory. Analysis of wastewater quality after treatment as well as wavelength during experiment has shown the improvement of the water sample can be obtained.

References

- [1] L. Fewtrell and J. Bartram, *Water quality: Guidelines, standards, and health: Assessment of risk and risk management for water-related infectious disease*: IWA Publishing, 2001.
- [2] P. R. Hunter, *et al.*, Estimating the impact on health of poor reliability of drinking water interventions in developing countries, *Science of the Total Environment*. 2009; 407: 2621-2624.
- [3] C. Jain, *et al.*, Assessment of ground water quality for drinking purpose, District Nainital, Uttarakhand, India, *Environmental monitoring and assessment*. 2010; 166: 663-676
- [4] R. P. Schwarzenbach, *et al.*, Global water pollution and human health, *Annual Review of Environment and Resources*. 2010; 35: 109-136.
- [5] J. A. Gonzalo, *et al.*, Using a rate equations approach to model World population trends, *Simulation*, 2013; 89: 192-198.
- [6] T. Tanning and L. Tanning, European Union labour force competitiveness in the world, *The International Journal of Arts and Commerce*. 2012; 6: 64-79.
- [7] M. Guardiola-Claramonte, *et al.*, Wastewater production, treatment and reuse around the Mediterranean region: current status and main drivers, in *Integrated Water Resources Management in the Mediterranean Region*, ed: Springer. 2012; 139-174.
- [8] M. Qadir, *et al.*, Wastewater production, treatment, and irrigation in Middle East and North Africa, *Irrigation and Drainage Systems*. 2010; 24: 37-51.
- [9] D. J. Van Rooijen, *et al.*, Urban growth, wastewater production and use in irrigated agriculture: a comparative study of Accra, Addis Ababa and Hyderabad, *Irrigation and Drainage Systems*. 2010; 24: 53-64.
- [10] D. L. Sedlak and U. von Gunten, The chlorine dilemma. *Science*. 2011; 331: 42-43.
- [11] F. B. Kakahi, *et al.*, A Review on the Role of Microorganisms in Treatment of Paper and Pulp Industry Effluent, *Nature, Environment and Pollution Technology*. 2011; 10: 361-368.
- [12] S. Palamthodi, *et al.*, Microbial degradation of textile industrial effluents, *African Journal of Biotechnology*. 2011; 10: 12657-12661.
- [13] P. Singh, *et al.*, Removal of pollutants from pulp and paper mill effluent by anaerobic and aerobic treatment in pilot-scale bioreactor, *International Journal of Environment and Waste Management*. 2011; 7: 423-431.
- [14] A. Singhal and I. S. Thakur, Two step sequential treatment of pulp and paper mill effluent by *Cryptococcus albidus* and *Emericella nidulans* var. *nidulans* in 2L bioreactor, *The Canadian Journal of Chemical Engineering*. 2012; 90: 739-744.
- [15] J. A. van Leeuwen, *et al.*, Changes in character of organics in the receiving environment of effluent from a sulphite pulp mill, *Environmental Science and Pollution Research*. 2012; 19: 2151-2158.
- [16] T. F. Davis, *et al.*, Development of a Biological Filter Utilizing Organic Growth Media for Wastewater Treatment and Nitrogen Oxidation. *Journal of Agricultural Science and Technology B*. 2012; 2: 64-75.
- [17] P. J. Westgate and C. Park, Evaluation of proteins and organic nitrogen in wastewater treatment effluents, *Environmental science & technology*. 2010; 44: 5352-5357.
- [18] N. Janzen, *et al.*, Transformation products and reaction kinetics of fragrances in advanced wastewater treatment with ozone, *Chemosphere*. 2011; 85: 1481-1486.
- [19] C. Von Sonntag and U. Von Gunten, Chemistry of Ozone in Water and Wastewater Treatment, *From Basic Principles to Applications*, 2012.
- [20] S.-H. Hu, *et al.*, Catalytic Degradation of Organic Wastewater Using Plasma Technique, *Environmental science & technology*. 2011; 34(1): 152- 154.