

Flicker Measurement and Grey Disaster Prediction of Grid-Connected Wind Turbines

Zhanqiang Zhang¹, Keqilao Meng², Li Zhang³

College of Information Engineering, Inner Mongolia University of Technology, Hohhot 010080,
Inner Mongolia Autonomous Region, China
e-mail: dzxzzq@163.com¹, mengke00@aliyun.com², 540216107@qq.com³

Abstract

Grid-connected operation of large-scale wind turbines (WTs) will have an impact on power quality of electric power systems. Therefore, on the basis of analyzing the International Electrotechnical standard IEC 61400-21, we described the measurement, evaluation method of the flicker of WTs and proposed the method of grey disaster prediction. Active power, reactive power, flicker coefficient and flicker severity of the WTs were tested on the actual wind farm according to IEC 61400-21 standard. We believed that the flicker severity was a disaster, so used the grey disaster prediction to predict the occurrence time of excessive flicker. Analysis of the test data of flicker was necessary, which could determine the Upper disaster threshold of the flicker. The disaster sequence was made up of the excessive flicker values. The date sequence was extracted from the disaster sequence. Establishing GM (1,1) model for the date sequence was to predict the future disaster date sequence. The experimental results showed that the relative accuracy of the disaster prediction model reached 94.87%, which was suitable for long-term flicker disaster prediction.

Keywords: Wind Turbines, Flicker, IEC 61400-21, Grey Disaster Prediction, GM (1,1)

1. Introduction

As a kind of renewable energy, wind power is one of the important alternative energy sources of the fossil fuel. Because wind power is random and unstable. With grid-connected operation of large-scale WTs, power fluctuation of WTs will bring negative effects to power quality; flicker is one of the main influence [1]-[3].

The purpose of this part of IEC 61400 [4] is to provide a uniform methodology which will ensure consistency and accuracy in the presentation, testing and assessment of power quality characteristics of grid-connected WTs. The power quality characteristics here include wind turbine specifications, voltage quality (emissions of flicker and harmonics), voltage drop response, power control, grid protection and reconnection time. The research focus was to measure, assess and predict the flicker of grid-connected WTs under continuous operation. According to IEC 61400-21 standard the reference [5] proposed a standard evaluation method which was based on testing the flicker coefficient $c(\psi_a, v_a)$ of a single WTs. The method could estimate the sum of flickers of more WTs connected to PCC (Point of Common Coupling), which proved the rationality of WTs flicker measurement and evaluation methods. The reference [6] established the virtual grid model and evaluated the power quality of WTs from two aspects of continuous operation and switching operation. The reference [7] proposed the method of continuous wavelet transform to recognize the power quality disturbances. The reference [8]-[10] assessed power quality comprehensively based on the theories of grey relational analysis, grey clustering and optimal combination of weights. The reference [11] used the grey system theory and radial basis function neural network to predict the flicker values according to the Japanese Δv_{10} index and obtained the better prediction results. The reference [12] used the grey model to predict the failure number of wind turbine blades.

This paper described the measurement and evaluation methods of the flicker based on studying IEC 61400-21 standard. The flicker coefficient of the actual wind farm was measured to calculate the flicker values. Grey disaster prediction was to forecast the date sequences of the flicker which exceeded the standard values. First, we identified the upper disaster sequence by studying the disaster sequence of the flicker. Then we studied the regularity of disaster

sequence and predicted the date sequences of disaster. Finally, we established the disaster sequence GM (1,1) model and realized grey disaster prediction of the flicker.

2. Measurement and assessment methods of flicker

The measurement procedures are valid for a single WT with a three-phase grid connection. The measurement procedures are valid for any size of WT, though this part of IEC 61400-21 only requires wind turbine types intended for PCC. Power quality characteristics measured at for example a test site can be considered valid also at other sites.

2.1. Flicker Measurement Procedures

Under continuous operation of WTs, the measurement and assessment process of flicker [4] is shown in Figure 1.

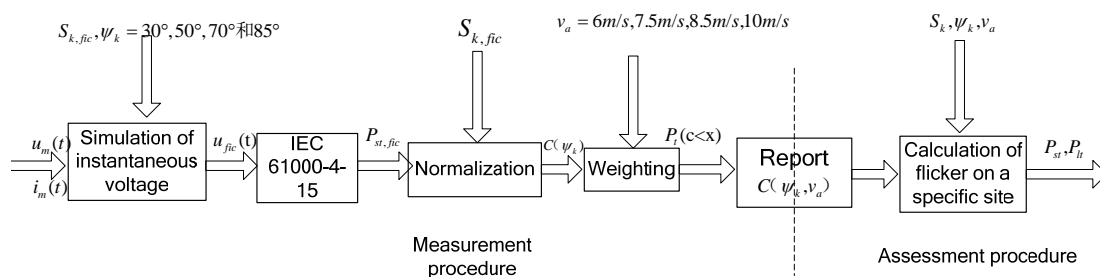

Figure 1. Measurement and assessment procedures for flicker during continuous operation of WTs

Measurements shall be taken so that at least five 10 min time-series of power are collected for each 1m/s wind speed bin between cut-in wind speed and 15 m/s. The test should be taken at least five times. The fifteen 10min time series of instantaneous voltage and current measurement data $u_m(t)$ and $i_m(t)$ are collected, wherein the average wind speed is 10min. Each set of measured time-series is used as input to simulate the voltage fluctuations, $u_{fic}(t)$ on a fictitious grid with an appropriate short-circuit apparent power $S_{k, fic}(t)$ and for four different network impedance phase angles ψ_k (block 1 in Figure 1). The time series of instantaneous simulated voltage $u_{fic}(t)$ is input to the voltage flicker algorithm described in IEC 61000-4-15[13] to generate the flicker emission value $P_{st, fic}$ (block 2 in Figure 1).

The flicker meter's functions can be divided into two parts:

- 1) It simulates the light-eye-brain response when the instantaneous voltage $u_{fic}(t)$ fluctuates by establishing a mathematical model;
- 2) It counts the flicker severity online, and calculates the 10min of the short-term flicker value.

$P_{st, fic}$ is calculated from the voltage fluctuation of $u_{fic}(t)$ under four different power network impedance phase angles ψ_k to obtain the flicker value. Each $P_{st, fic}$ value is normalized to a flicker coefficient $c(\psi_k)$ (block 3 in Figure 1).

$$c(\psi_k) = P_{st} \frac{S_{k, fic}}{S_n} \tag{1}$$

In the equation (1), $S_{k, fic}$ is short-circuit capacity of the virtual grid, S_n is rated apparent power of a single WTs. To ensure the flicker measurement instrument within the range specified

in IEC61000-4-15, we should adopt the appropriate short-circuit ratio $S_{k, fic}/S_n$. IEC 61400-21 standard recommends the short-circuit ratio is between 20-50.

For each network impedance phase angle ψ_k , the weighting procedure calculates the weighted accumulated distribution functions of the flicker coefficient $P_r(c < x)$, assuming four different wind distributions. For each accumulated distribution, the 99% percentile $c(\psi_k, v_a)$ is reported (block 4 and block 5 in Figure 1).

2.2. Flicker Assessment Procedures

If you get a flicker coefficient $c(\psi_k, v_a)$, you can calculate flicker P_{st} or P_{lt} on any specified site through the parameters of S_k , ψ_k and v_a . The flicker emission from a single WT during continuous operation shall be estimated applying the equation (2) below.

$$P_{st} = P_{lt} = c(\psi_k, v_a) \frac{S_n}{S_k} \quad (2)$$

In case more WTs are connected to the PCC, the flicker emission from the sum of them can be estimated from the equation (3) below.

$$P_{st\Sigma} = P_{lt\Sigma} = \frac{1}{S_k} \sqrt{\sum_{i=1}^{N_{wt}} (c_i(\psi_k, v_a) S_{n,i})^2} \quad (3)$$

If the wind farm uses the same model of WTs, the flicker emission from the sum of them can be simplified as the equation (4) below.

$$P_{st\Sigma} = P_{lt\Sigma} = \frac{S_{n,i}}{S_k} c(\psi_k, v_a) \sqrt{N_{WT}} \quad (4)$$

Where N_{wt} is the number of WTs connected to the PCC.

3. Flicker Test

3.1. System Description

In this paper, the test data were measured on the BAIYUN wind farm in Inner Mongolia. The wind farm center is located about 109°56'40" east longitude, 41°44'46" north latitude, with the average altitude of 1565m. The annual wind speed of this site at hub height is estimated to be 8 m/s. The average wind power density is 523.6W/m². The total installed capacity of the wind farm is 49MW, the rated power for a single WT is 810KW, the output voltage is 0.69KV. The wind farm installed the double armature hybrid excitation WTs, which combine the advantage of VSCF (Variable Speed Constant Frequency) generator and CSCF (Constant Speed Constant Frequency) generator. The generator has high power generation efficiency and simple control features. On the wind farm a step-up transformer substation with 220KV was constructed. The main wiring diagram of the wind farm is shown in Figure 2.

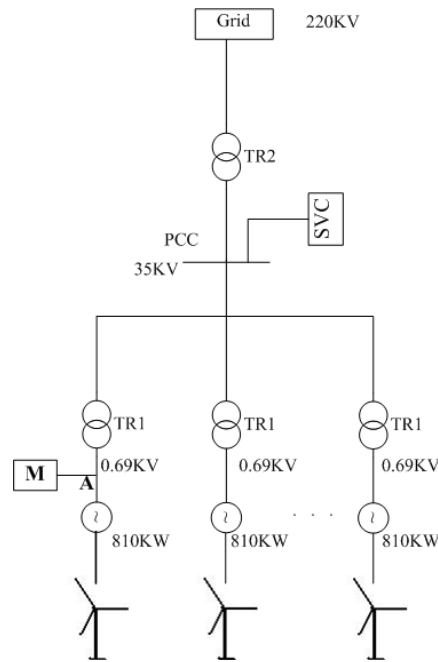

Figure 2. Main wiring diagram of the wind farm

Power quality measurements were taken from a single WT's terminal on the low voltage side of the transformer TR1, which was shown at point A in Figure 2. We could calculate the flicker of multiple WTs connected to PCC by the equation (4). The measurement was carried out from 16:10 on November 26, 2013 to 12:00 November 26, 2013, which had 1200 minutes in total.

3.2. Flicker Test

The measurement data of 10 min time series of instantaneous voltage and current were collected. The voltage and current sample frequency was 10.24 KHz, the wind speed sample frequency was 5Hz and accuracy of the anemometer was ± 0.2 m/s. In accordance with IEC 61400-21 standard, the measurement data of three-phase voltage and current were used to calculate the flicker coefficient. The system was in equilibrium by analyzing the test data, so the data of phase 1 were used only.

3.2.1. Active and Reactive Power Test

The active and reactive power of the WTs were tested under the continuous operation state. The trend of the active and reactive power had consistency, which could be seen from Figure 3. There was a certain proportional relationship between the active power and reactive power, $\tan \varphi = Q/P$, where φ was the power factor angle. Within the range of rated wind speed, the output power of WTs increased with increasing wind speed.

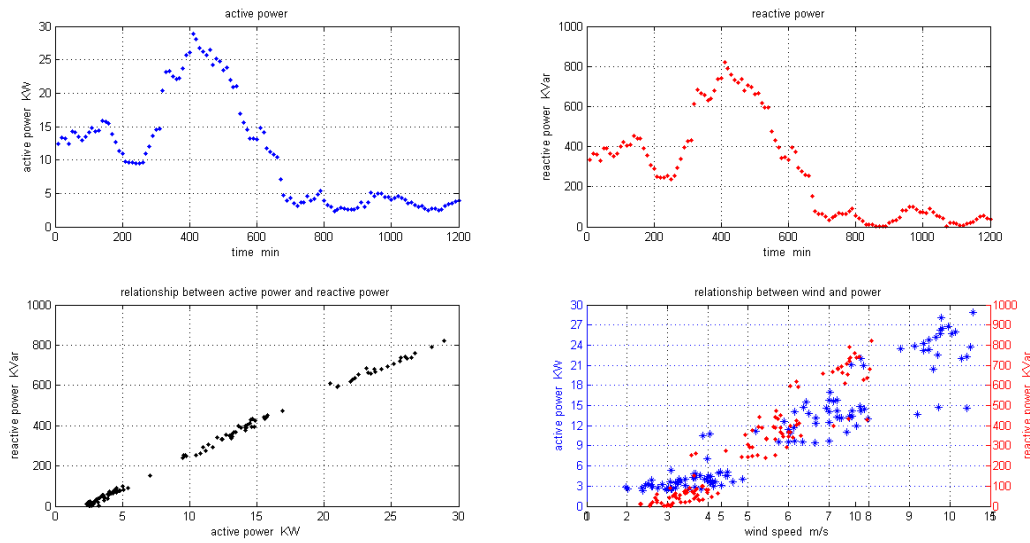

Figure 3. Active Power and Reactive Power

3.2.2. Relationship between Wind Speed and Flicker Coefficient

It can be seen from Figure 4 that the function relation between flicker coefficient and wind speed when the network impedance phase angle ψ_k are $30^\circ, 50^\circ, 70^\circ$ and 85° , the short-circuit ratio is 50. The larger grid impedance phase angle is, the greater flicker coefficient is.

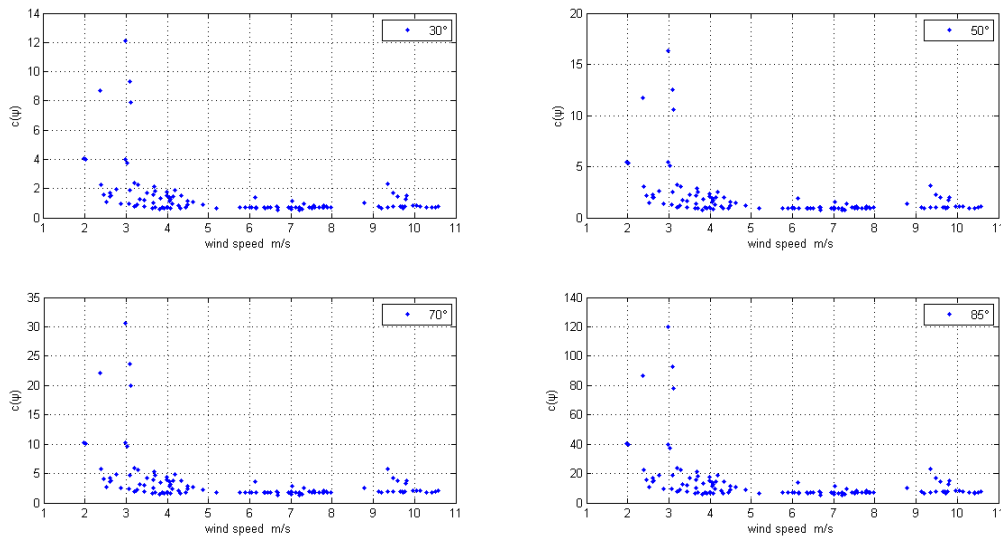

Figure 4. Relationship between Wind Speed and Flicker Coefficient

3.2.3. Measurement of Short-term Flicker

The flicker of WTs can be measured from two aspects of continuous operation and switching operation. In this paper we studied the measurement of flicker under continuous operation. The generation of flicker under continuous operation was caused by changes in wind speed, which caused the changes of reactive and active power. The measurement period of short-time flicker is 10 minutes, the measurement period of long-time flicker is 2 hours. In the

continuous operation state, P_{st} and P_{ft} have the same flicker value. If the flicker value of WTs exceeds the limit value ($P_{st}=1$), it would affect the operation of the power system. The upper limit values of $P_{st}=1$ and $P_{st}=0.5$ were marked in Figure 5. $P_{st}=0.5$ was the upper disaster limit value of flicker grey disaster prediction.

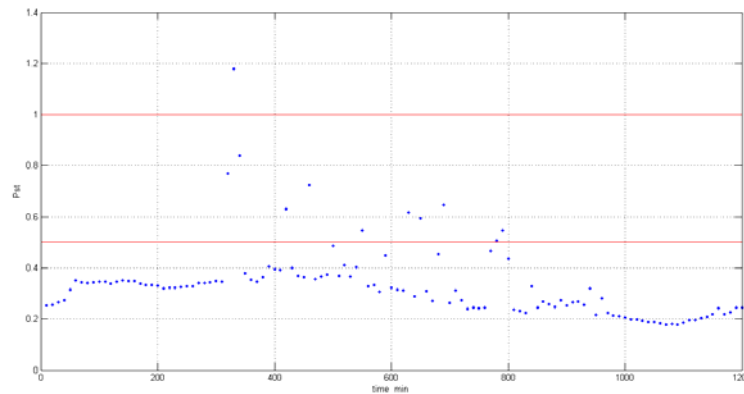

Figure 5. Measurements of Short-term Flicker

4. Model of Flicker Grey Disaster Prediction

The thoughts of flicker grey disaster prediction were as follows: The measurement values of flicker P_{st} were finite, it met that grey system used the "poor information" as the research object. The threshold value of flicker was set 0.5 according to the measured value. Because in the stable operation of WTs, and when the measurement time was short, more than 1 of the value of P_{st} was less. The less data could affect the establishment of grey disaster prediction model, so we chose $P_{st}=0.5$ as the threshold. If the value of the original sequence exceeded the threshold, then the disaster points were selected to constitute a sequence that was called disaster sequence. The disaster sequence was made up of the excessive flicker value. The date sequence was made up according to the occurrence time of each excessive flicker value. Establishing GM (1,1) model for the date sequence to predict the future disaster date sequence [14].

4.1. Method of Grey Disaster Prediction

Time series data of grey disaster prediction are as follows:

$$X^{(0)}(t) = \{X^{(0)}(1), X^{(0)}(2), \dots, X^{(0)}(N)\} \quad (5)$$

If the threshold value λ are given, the numbers in $X^{(0)}(t)$ which is larger than λ (upper-disaster value) or less than λ (down-disaster value) are regarded as abnormal values. And then we select the abnormal values which form a new data sequence, which is called the disaster sequence.

$$X^{(0)'}(t) = \{X^{(0)}(i_1), X^{(0)}(i_2), \dots, X^{(0)}(i_m)\}, m < N \quad (6)$$

The sequence of disaster time is made up according to occurrence time of each data in the formula (7).

$$Q^{(0)}(t) = \{Q^{(0)}(1), Q^{(0)}(2), \dots, Q^{(0)}(m)\}, m < N \quad (7)$$

We use the $X^{(0)}(t)$ data sequence to establish GM (1,1) model to predict the occurrence time in the future. The GM (1,1) model is described as follows.

Denote the original data sequence as:

$$X^{(0)}(t) = \{X^{(0)}(1), X^{(0)}(2), \dots, X^{(0)}(n)\} \quad (8)$$

Where n is the number of P_{st} observed.

The AGO formation of $X^{(0)}(t)$ is defined as:

$$X^{(1)}(t) = \{X^{(1)}(1), X^{(1)}(2), \dots, X^{(1)}(n)\} \quad (9)$$

Where

$$X^{(1)}(k) = \sum_{i=1}^k X^{(0)}(i), \quad i = 2, 3, \dots, n \quad (10)$$

GM (1,1) model can be constructed by establishing a first order differential equation for $X^{(1)}(t)$ as:

$$\frac{dx^{(1)}}{dt} + ax^{(1)} = b \quad (11)$$

The solution of (11) can be obtained by using the least square method. That is,

$$\hat{x}(k+1) = [x^{(0)}(1) - \frac{b}{a}]e^{-ak} + \frac{b}{a} \quad (12)$$

Where

$$\hat{a} = (a, b)^T \quad (13)$$

The values of a and b are given using the least squares method.

$$\hat{a} = (B^T B)^{-1} B^T Y \quad (14)$$

Where

$$Y = \begin{bmatrix} x^{(0)}(2) \\ x^{(0)}(3) \\ \dots \\ x^{(0)}(n) \end{bmatrix} \quad (15)$$

$$B = \begin{bmatrix} -\frac{1}{2}(x^{(1)}(1) + x^{(1)}(2)) & 1 \\ -\frac{1}{2}(x^{(1)}(2) + x^{(1)}(3)) & 1 \\ \dots & \dots \\ -\frac{1}{2}(x^{(1)}(n-1) + x^{(1)}(n)) & 1 \end{bmatrix} \quad (16)$$

The simulation values of $X^{(0)}(k)$ is

$$\hat{x}^{(0)}(k+1) = \hat{x}^{(1)}(k+1) - \hat{x}^{(1)}(k) \quad (17)$$

4.2. Flicker disaster date forecast

The data of establishing the disaster prediction model were taken from the test data of P_{st} . The original data sequence was:

$$X^{(0)}(t) = \{0.2534, 0.2541, 0.2652, 0.2727, \dots, 0.7709, 1.1797, 0.8404, \dots, 0.2275, 0.2443, 0.2442\} \quad (18)$$

According to the actual test conditions of the system, the disaster is happened when the value of P_{st} is greater than or equal to 0.5. The procedures of flicker disaster prediction [15]-[16] are shown as follows:

1) The value, which is greater than or equal to the threshold of 0.5, are selected from the original data $X^{(0)}(t)$. This disaster sequences are formed as follows:

$$X^{(0)'}(t) = \{0.7709, 1.1797, 0.8404, 0.631, 0.722, 0.5468, 0.6169, 0.5929, 0.6457, 0.506, 0.5479\} \quad (19)$$

2) The disaster sequence is:

$$X^{(0)'}(t) = \{X^{(0)}(32), X^{(0)}(33), X^{(0)}(34), X^{(0)}(42), X^{(0)}(46), X^{(0)}(55), X^{(0)}(63), X^{(0)}(65), X^{(0)}(69), X^{(0)}(78), X^{(0)}(79)\} \quad (20)$$

3) The sequence of disaster time is:

$$Q^{(0)}(t) = \{32, 33, 34, 42, 46, 55, 63, 65, 69, 78, 79\} \quad (21)$$

4) Establishing the GM (1, 1) model for the sequence of disaster time. The 1-AGO sequence is:

$$Q^{(1)}(t) = \{32, 65, 99, 141, 187, 242, 305, 370, 439, 517, 596\} \quad (22)$$

Next generation sequence is:

$$Z^{(1)}(t) = \{48.5, 82, 120, 164, 214.5, 273.5, 337.5, 404.5, 478, 556.5\} \quad (23)$$

We use the least-squares method to solve the a and b, then we can obtain:

$$\hat{a} = \begin{bmatrix} a \\ b \end{bmatrix} = \begin{bmatrix} -0.0966 \\ 30.5236 \end{bmatrix} \quad (24)$$

The GM (1, 1) model is:

$$\hat{Q}^{(1)}(t+1) = 347.98e^{0.0966t} - 315.98 \quad (25)$$

The reducing value is:

$$\hat{Q}^{(0)}(t+1) = 32.04e^{0.0966t} \quad (26)$$

5. Results and Discussion

In the paper we measured the flicker coefficient and wind speed when ψ_k were $30^\circ, 50^\circ, 70^\circ$ and 85° , which could be seen from Figure 4. P_{st} could be calculated by the equation (2). The 120 data were obtained as shown in Figure 5. We could predict the occurrence time of excessive flicker by the equation (26) which could be seen from the Table 1.

Table 1. Error check table

serial number	Original data $Q^{(0)}(t)$	Analog data $\hat{Q}^{(0)}(t)$	Residual error $\varepsilon(k) = Q^{(0)}(t) - \hat{Q}^{(0)}(t)$	Relative error $\Delta_k = \frac{ \varepsilon(k) }{Q^{(0)}(t)}$
1	32	32.0000	0	0
2	33	35.2914	-2.2914	6.94%
3	34	38.8703	-4.8703	14.32%
4	42	42.8120	0.8120	1.93%
5	46	47.1535	1.1535	2.51%
6	55	51.9353	3.0647	5.56%
7	63	57.2020	5.798	9.20%
8	65	63.0028	1.9972	3.07%
9	69	69.3918	0.3918	0.57%
10	78	76.4287	1.5713	2.01%
11	79	84.1793	5.1793	5.56%

Through analysis of the test data and disaster prediction, we drew conclusions as follows:

- 1) The calculation of flicker coefficient is closely related to the network impedance phase angles and annual average wind speed.
- 2) In order to improve the accuracy of flicker prediction, we should measure the more data to establish the disaster prediction model.
- 3) The prediction results showed that the average relative error was $\Delta = \frac{1}{10} \sum_{k=2}^{11} \Delta_k = 5.13\%$, the relative accuracy was 94.87%, which the fitting result is satisfactory.
- 4) The development coefficient of GM (1,1) model was $a = -0.0966$. The literature [17] concluded that GM (1,1) model could be used to predict the long-term flicker disaster when $-a \leq 0.3$.

6. Conclusion

According to IEC 61400-21 standard, we measured the short-term flicker and flicker coefficient of a single WTs on the wind farm, and got the flicker values of multi-WTs through the flicker assessment procedures. We should fully consider the influence of wind speed on the measurement value, and ensure the reliability of the test. We tested the short term flicker P_{st} values and predicted the occurrence time of excessive flicker by using the grey system theory. The relative accuracy of the model was higher. Its fitting result was better, which suited the long-term prediction for flicker disaster.

Acknowledgments

This paper was supported by National Natural Science Foundation of China (51167011, 51467016), Inner Mongolia science and technology plan project (20130303) and the cooperation project of China and Denmark (2009DFB60250).

References

- [1] Sun T, Wang WS, Dai HZ. Voltage Fluctuation and Flicker Caused by Wind Power Generation. *Power System Technology*. 2003; 27(12): 62-66.

-
- [2] Dong WJ, Bai XM, Zhu NH. Discussion on the Power Quality under Grid-Connection of Intermittent Power Sources. *Power System Technology*. 2013; 37(5): 1265-1271.
- [3] Chi YN, Liu YH, Wang WS. Study on Impact of Wind Power Integration on Power System. *Power System Technology*. 2007; 31(3): 77-81.
- [4] IEC Standards Association. 61400-21. Measurement and assessment of power quality characteristics of grid connected wind turbines. Switzerland: IEC Press. 2008.
- [5] Braulio B, Poul S, Leif C. Validation of the Standard Method for Assessing Flicker From Wind Turbines. *IEEE TRANSACTIONS ON ENERGY CONVERSION*. 2011; 26(1): 373-378.
- [6] A Tascikaraoglu, M Uzunoglu, B Vural. Power quality assessment of wind turbines and comparison with conventional legal regulations: A case study in Turkey. *Applied Energy*. 2011; 88(12): 1864–1872.
- [7] Manoj G, Rajesh K, Ram AG. Neural Network Based Indexing and Recognition of Power Quality Disturbances. *TELKOMNIKA Telecommunication Computing Electronics and Control*. 2011; 9(2): 227-236.
- [8] Lei G, Gu W, Yuan XD. Application of grey theory in power quality comprehensive evaluation. *Electric Power Automation Equipment*. 2009; 37(11): 62-65.
- [9] Zhou H, Yang HG, Wu CL. A power quality comprehensive evaluation method based on grey clustering. *Power System Protection and Control*. 2012; 40(15): 70-75.
- [10] Shen Y, Peng X, Shi T. A Grey Comprehensive Evaluation Method of Power Quality Based on Optimal Combination Weight. *Automation of electric Power Systems*. 2012; 36(10): 67-73.
- [11] HJ Lu, GW Chang, HJ Su. *A New Method for Flicker Severity Forecast*. IEEE Power and Energy Society General Meeting (PES). Canada. 2013: 1-5.
- [12] Yu CY, Guo JY, Xin SG. Failure Mechanism Analysis and Failure Number Prediction of Wind Turbine Blades. *TELKOMNIKA Telecommunication Computing Electronics and Control*. 2014; 12(3): 533-540.
- [13] IEC Standards Association. 61000-4-15. *Testing and measurement techniques—Flickermeter Functional and design specifications*. Switzerland: IEC Press. 2010.
- [14] Liu S, Dang Y, Fang Z. *Grey Systems Theory and Application*. Beijing: Science Press. 2010: 226-247.
- [15] Jie C, Si FL, Bo Z. A novel grey forecasting model and its optimization. *Applied Mathematical Modelling*. 2013; 37(6): 4399-4406.
- [16] Bo Z, Guo C, Si FL. A novel interval grey prediction model considering uncertain information. *Journal of the Franklin Institute*. 2013; 350(10): 3400–3416.
- [17] Liu S, Deng J. The Range Suitable for GM (1,1). *Systems Engineering —Theory&Practice*. 2000; 20(5): 212-124.